

AUGUST 2020

SCIENTIFICAMERICAN.COM

SCIENTIFIC AMERICAN



ANIMAL SOCIAL DISTANCING // QUANTUM MYSTERY SOLVED // GALILEO'S PLAGUE



ASCENT OF THE OAKS

How they grew to dominate
North American forests



Gremlin/Getty Images

THE SECRETS OF AWARD-WINNING SCIENCE

The best scientists make discoveries that transform how we understand the world around us. Three newly minted Kavli Prize laureates offer exclusive insights into how they reached the forefront of their fields.

At its best, science uncovers the extraordinary. It reveals wonders of the natural world that we could never have imagined: the trembling interactions of individual atoms, the movement of molecules that convey our sensations, the jets of hot gases that rush from a supermassive black hole.

In labs and in the field, at microscopes and telescopes, scientists strive for such breakthroughs. Every two years, The Kavli Prize honors scientists who manage to blaze new trails time and again. To find out how they do it, Scientific American Custom Media obtained exclusive early access to three scientists who in May were named Kavli Prize laureates in nanoscience, neuroscience or astrophysics.

Each of these researchers distinguished themselves by coaxing nature to give up tightly held secrets, whether by probing the evolution of galaxies, sharpening the images that electron microscopes produce, or revealing the elegant neural mechanisms that ensure animals, and humans, receive warnings from their sense of pain. To uncover what sets scientists of this caliber apart, we asked the laureates for their perspective on how award-winning science happens.

The stories they shared demonstrate how preparation, mindset, technical innovation, and grit—combined with curiosity, passion, and some luck—can transform the sometimes

pedestrian process of science into a transcendent journey of discovery.

**RECIPIENT OF THE 2020 KAVLI PRIZE IN ASTROPHYSICS:
ANDREW FABIAN,**
INSTITUTE OF ASTRONOMY,
UNIVERSITY OF CAMBRIDGE



By examining X-ray data from supermassive black holes, Andrew Fabian revealed how they convert matter into energy, which they then spew into the galactic space that surrounds them. A believer in the power of serendipity, Fabian recalls how chasing down an unexpected observation led him to discover that matter plummeting into a black hole can produce sound waves, a process that influences how galaxies evolve.

Louis Pasteur said that chance favors the prepared mind. Maybe you notice a glitch in the data—something that isn't quite right, that looks slightly different from what you had predicted. If you're prepared, you can recognize when you're seeing something genuinely new that might send you along a different path.

Around 2000, we started using the Chandra X-ray Observatory to look much deeper, in much greater detail, at the Perseus cluster. When I looked at the Chandra images we collected in 2002, I spotted subtle concentric ripples in the brightness of the intracluster gas. I realized they resembled strong sound waves. The spacing of those ripples was just right to account for the energy emitted by the X-rays we observed. This meant that the sound waves were transferring energy from the region near the supermassive black hole at the center of the cluster out into the surrounding gas.

This was something we'd never considered before. When you take a book and drop it, its gravitational potential energy is converted to kinetic energy, and when the book hits the floor, a small amount of that energy is converted into sound. In the Perseus cluster, you're dropping matter down the deepest hole you can find—a black hole. This generates enormous amounts of energy, which can push gas out of the galaxy and prevent star formation.

The universe is full of wondrous things—and the more closely you look, the more you find.

CO-RECIPIENT OF THE 2020 KAVLI PRIZE IN NANOSCIENCE:

ONDREJ KRIVANEK,
CO-FOUNDER AND PRESIDENT,
NION COMPANY



Ondrej Krivanek shared The Kavli Prize in Nanoscience with the team of Harald Rose, Maximilian Haider and Knut Urban for independent advances that sharpened the resolution of electron microscopes, enabling scientists worldwide to visualize and analyze materials atom by atom. For his part, Krivanek designed hardware to correct image-distorting aberrations produced by the lenses that focus the microscopes' electron beam. The achievement required remarkable grit—and an ability to engineer a solution one step at a time.

Our first corrector went into a 20-year-old microscope. We just sliced it open, put our corrector in it, closed it up, and focused all of our efforts on the corrector. We were not looking for perfection. We were after a proof of principle—just showing that it will work.

We realized that once you correct the spherical aberration, all sorts of other little aberrations begin to pop out. We then had to analyze and fix each of them, one by one. That was an important lesson. You don't want to have to fight five fires at the same time. For big projects, you have to divide your problem into smaller, independent steps to increase your chances of success.

Once we had a working corrector, we started to make our own microscopes. We saw spectacular results—results we could not have gotten if we had not sweated the details. When a new class of materials came along—a one-layer-thick sample of graphene—my Nion colleague, Niklas Dellby, and I flew to Oak Ridge National Laboratory and got on the microscope we had sent there. It was probably 10 o'clock at night when the whole picture came in spectacularly clearly.

You could see every single atom. We could watch the atoms rearrange, all in real time. It was a revelation. I pushed back from the microscope and said to my partner: "We made a—there's a word that starts with an 'F'—good microscope."

CO-RECIPIENT OF THE 2020 KAVLI PRIZE IN NEUROSCIENCE:

DAVID JULIUS,
UNIVERSITY OF CALIFORNIA,
SAN FRANCISCO



David Julius shared The Kavli Prize in Neuroscience with Ardem Patapoutian for identifying the molecular mechanisms that underlie our ability to sense mechanical pressure and temperature. Using capsaicin—the chemical that gives chili peppers their kick—Julius identified a protein that protects us from injury by detecting heat, inflammation and pain, and that could lead to new and better analgesics. The discovery required a willingness to take a big risk to pursue something no one was even sure existed.

Who's not curious about knowing why chili peppers seem pungent? It's one of these things in science where you know that there's a mystery and if you solve it, it's going to be fascinating. I decided that if I'm going to get into pain biology, it would be very interesting to

ask whether there really is a molecular receptor on which capsaicin works.

When Mike Caterina came to the lab as a postdoctoral fellow, I said, "Look, this is a risk, but if we do this, it's going to be really exciting." Mike and I kicked around a bunch of ideas, then put together this cloning screen. It relied on the idea that if you took a non-neuronal cell and you were to transfer into it the gene that encoded the capsaicin receptor—and then activate it with capsaicin—it would let calcium into the cell. The late Roger Tsien had invented fluorescent dyes that enable you to detect such an event.

One day Mike said, "I want to show you something." We went into the darkroom. The cells were all sort of dark. And then he put on capsaicin, and boom, all of a sudden, a little cluster of cells just lit up and turned this beautiful sort of reddish color. And I said, "You've cloned it!" It was an amazing moment—and a great example of how scientists can use a natural product to understand a key signaling mechanism in our nervous system.

When you have a problem you're passionate about, it's always worth coming back to. Sure, there's a certain art in knowing when to call it quits. But I think it's worth taking a risk for something that could be really transformative.

To hear more from Andrew Fabian, Ondrej Krivanek, David Julius, and other Kavli Prize laureates about the biggest questions in science, visit www.scientificamerican.com/custom-media/biggest-questions-in-science/.

THE  KAVLI PRIZE

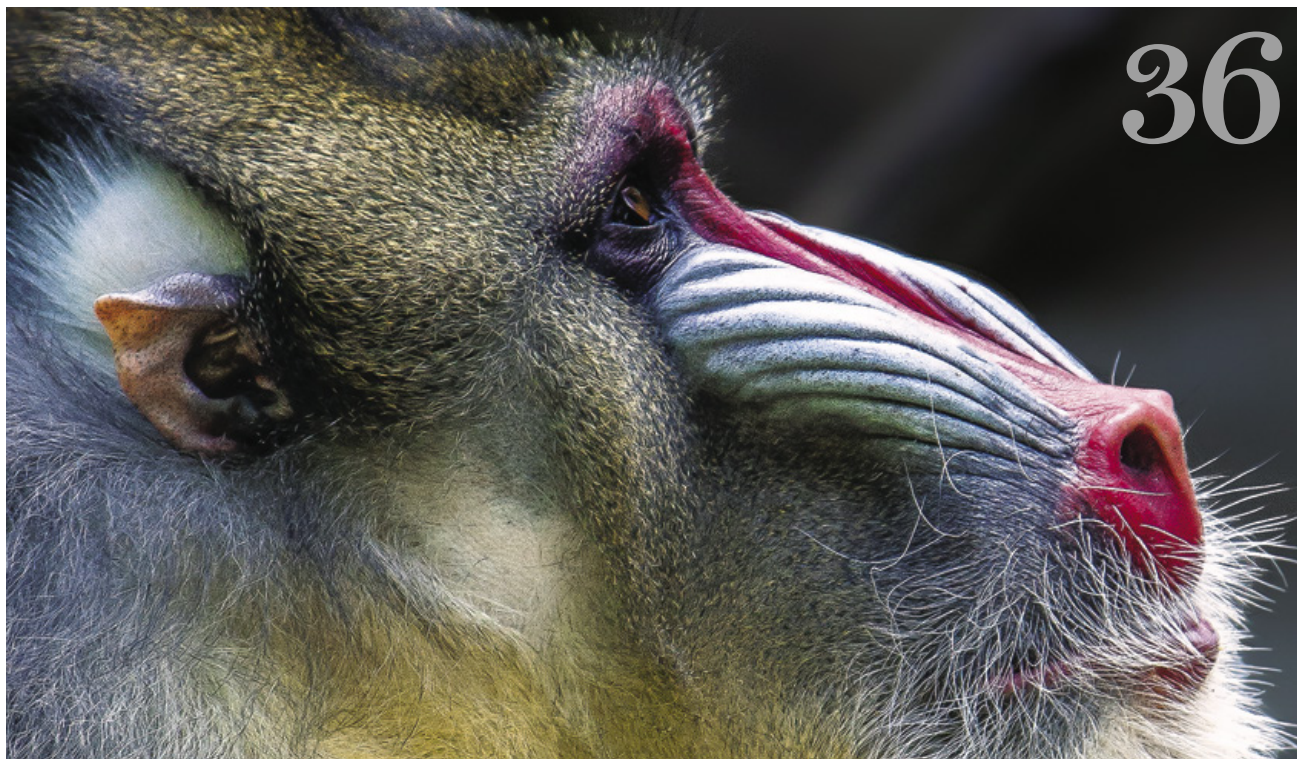

- ECONOMICS**
- 24 Measuring What Matters**
Gross domestic product fails to count the things that make for a healthy society.
By Joseph E. Stiglitz
- HISTORY OF SCIENCE**
- 32 Galileo's Lessons for Living through a Plague**
An outbreak in Italy in the 1630s forced him to find new ways of doing his research and connecting with his family. *By Hannah Marcus*
- ECOLOGY**
- 36 Animals Apart**
People are struggling with social distancing, but lobsters, birds and some primates routinely use the strategy to ward off disease.
By Dana M. Hawley and Julia C. Buck
- EVOLUTION**
- 42 Ascent of the Oaks**
Genomic studies reveal the remarkable evolutionary history

of oak trees. *By Andrew L. Hipp, Paul S. Manos and Jeannine Cavender-Bares*

- MATHEMATICAL PHYSICS**
- 50 Quantum Leap**
The quest to solve one of the greatest open questions in physics: How can a quantum phenomenon become macroscopic?
By Spyridon Michalakis
- ANTHROPOLOGY**
- 58 Survival of the Friendliest**
Natural selection for hypersocial traits enabled Earth's apex species to best competitors.
By Brian Hare and Vanessa Woods
- SUSTAINABILITY**
- 64 The Biomass Bottleneck**
Strategies for drawing down carbon dioxide depend on more trees, grasses and crop residues than the planet can spare.
By Eric Toensmeier and Dennis Garrity



ON THE COVER
Oak trees are hugely diverse, with some 435 species worldwide, and they are essential to the functioning of the forests they inhabit. Recent genomic studies have allowed researchers to chart their rise to prominence.
Photograph by Steve Zimic.

THE NORWEGIAN ACADEMY OF SCIENCE AND LETTERS
ANNOUNCES THE 2020 LAUREATES OF

THE KAVLI PRIZE

THE KAVLI PRIZE IN ASTROPHYSICS

Selection Committee: Viggo Hansteen (Chair), University of Oslo, Norway; Alessandra Buonanno, Max Planck Institute for Gravitational Physics, Germany; Andrea Ghez, University of California, Los Angeles, USA; Robert C. Kennicutt, Jr, University of Arizona, US; Irwin I. Shapiro, Harvard University, USA

for groundbreaking research in the field of observational X-ray astronomy, covering a wide range of topics from gas flows in clusters of galaxies to supermassive black holes at the heart of galaxies

ANDREW FABIAN, University of Cambridge, UK

THE KAVLI PRIZE IN NANOSCIENCE

Selection Committee: Bodil Holst (Chair), University of Bergen, Norway; Gabriel Aeppli, Paul Scherrer Institut, Switzerland; Susan Coppersmith, University of New South Wales, Australia; Shuit-Tong Lee, Soochow University, China; Joachim Spatz, Max Planck Institute for Medical Research, Germany

for sub-ångström resolution imaging and chemical analysis using electron beams

HARALD ROSE Universität Ulm, Germany
MAXIMILIAN HAIDER CEOS GmbH, Germany
KNUT URBAN Forschungszentrum Jülich, Germany
ONDREJ L. KRIVANEK Nion Co, USA

THE KAVLI PRIZE IN NEUROSCIENCE

Selection Committee: Kristine B. Walhovd (Chair), University of Oslo, Norway; Alexander Borst, Max Planck Institute of Neurobiology, Germany; Catherine Dulac, Harvard University, USA; Mary E. Hatten, The Rockefeller University, USA; Denis Le Bihan, NeuroSpin, CEA, France

for the transformative discovery of receptors for temperature and pressure

DAVID JULIUS UC San Francisco, USA
ARDEM PATAPOUTIAN Scripps Research, USA

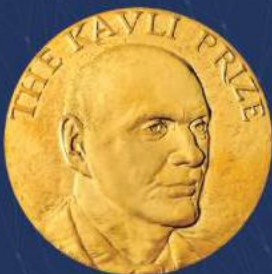

kavliprize.org

The Kavli Prize is a partnership among The Norwegian Academy of Science and Letters, The Norwegian Ministry of Education and Research, and The Kavli Foundation (USA).



10

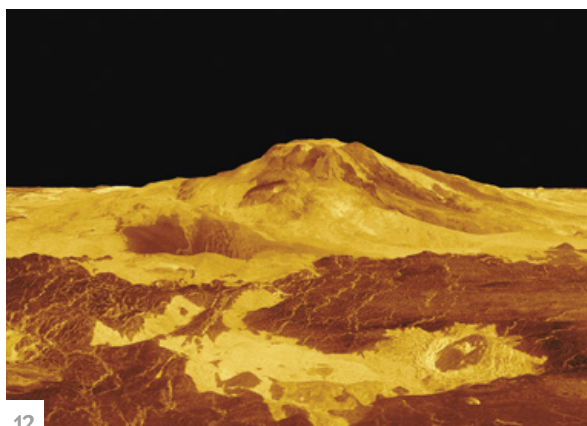

12



75

5 From the Editor

6 Letters

8 Science Agenda

Too many people of color lack access to basic health care.
By the Editors

10 Forum

Wearing a mask as a precaution against the coronavirus is not a sign of emasculation. *By Peter Glick*

12 Advances

A toxic transformation on Venus. A devastating 1,000-year-old tsunami. Building brain circuitry at the cellular level. Pills that could give lifesaving time to treat snakebites.

22 Meter

Gravitational waves and the poetry of Blackfoot. *By Jessica Reed*

23 The Science of Health

The American epidemic of suicide among young people has been raging for 20 years. *By Claudia Wallis*

73 Recommended

Hard-won battles by women in science. Keeping the Mississippi in place. Stockholm syndrome redux. *By Andrea Gawrylewski*

75 Observatory

Why science denial is easy to generate and hard to slay.
By Naomi Oreskes

76 Anti Gravity

COVID-19 has done away with handshaking—for the greater good. *By Steve Mirsky*

77 50, 100 & 150 Years Ago

By Daniel C. Schlenoff

78 Graphic Science

Name-dropping hurricanes. *By Mark Fischetti and Will Chase*

SPECIAL REPORT

S1 Nature Outlook: Extracellular RNA

Best known for its part in translating genetic code into protein making, RNA is finding a new role in medicine. This report, from *Nature*, explores how it is helping to detect and treat disease.

Scientific American (ISSN 0036-8733), Volume 323, Number 2, August 2020, published monthly by Scientific American, a division of Springer Nature America, Inc., 1 New York Plaza, Suite 4600, New York, N.Y. 10004-1562. Periodicals postage paid at New York, N.Y., and at additional mailing offices. Canada Post International Publications Mail (Canadian Distribution) Sales Agreement No. 40012504. Canadian BN No. 127387652RT; TVQ1218059275 TQ0001. Publication Mail Agreement #40012504. Return undeliverable mail to Scientific American, P.O. Box 819, Str. Main, Markham, ON L3P 8A2. **Individual Subscription rates:** 1 year \$49.99 (USD), Canada \$59.99 (USD), International \$69.99 (USD). **Institutional Subscription rates:** Schools and Public Libraries: 1 year \$84 (USD), Canada \$89 (USD), International \$96 (USD). Businesses and Colleges/Universities: 1 year \$399 (USD), Canada \$405 (USD), International \$411 (USD). Postmaster: Send address changes to Scientific American, Box 3187, Harlan, Iowa 51537. **Reprints inquiries:** RandP@sciam.com. **To request single copies or back issues, call (800) 333-1199.** **Subscription inquiries:** U.S. and Canada (800) 333-1199; other (515) 248-7684. Send e-mail to scacustserv@cdsfulfillment.com. Printed in U.S.A. Copyright © 2020 by Scientific American, a division of Springer Nature America, Inc. All rights reserved.



Scientific American is part of Springer Nature, which owns or has commercial relations with thousands of scientific publications (many of them can be found at www.springernature.com/us). Scientific American maintains a strict policy of editorial independence in reporting developments in science to our readers. Springer Nature remains neutral with regard to jurisdictional claims in published maps and institutional affiliations.



Laura Helmuth is editor in chief of *Scientific American*. Follow her on Twitter @laurahelmuth

Lessons from the Natural World

During this strange and scary pandemic year, a lot of people have been spending more time outdoors, admiring flowers and listening to birds they may have rushed past in the Before Times. The more you learn about nature, the more fascinating it is, and this month's cover story on oaks may help you appreciate these majestic trees. Plant scientists Andrew L. Hipp, Paul S. Manos and Jeannine Cavender-Bares show that over the past 56 million years, oaks have evolved into 435 species with elaborate adaptations that let them thrive in habitats around the world, dominating many North American forests. Turn to page 42.

Our other natural world feature story this month reveals that we can learn pandemic survival skills from other species. House finches, spiny lobsters, guppies, ants, mandrills, and more can recognize illness and practice social isolation to avoid infecting others in the group. Dana M. Hawley and Julia C. Buck, experts on animals and disease, describe these newly relevant behaviors, starting on page 36.

We can learn from history as well. A plague outbreak in the 1630s gave Galileo an excuse to publish his *Dialogue concerning the Two Chief World Systems* (the one about how Earth moves around the sun) in nearby Florence rather than Rome, evading the Vatican's censors, at least for a while. He had to quarantine when summoned for a trial for heresy, and his daughter sent pro-

visions to care for him remotely. Historian Hannah Marcus begins the story on page 32.

Humans became human through friendliness, researchers Brian Hare and Vanessa Woods assert on page 58, likening the process to the domestication of wolves into dogs. The ability to create large and versatile social networks may have been our greatest evolutionary advantage.

Having a strong and healthy community is a key indicator of quality of life, according to Joseph E. Stiglitz (*page 24*). He and other economists increasingly say that gross domestic product is a mismeasure of a country's economic well-being, and a focus on GDP has impaired our ability to prepare for pandemics. Education, environmental quality, housing, safety and health are what really matter.

Limiting climate change will require many solutions, and agroforestry experts Eric Toensmeier and Dennis Garrity explain on page 64 how growing trees among crops and pastures can use land more efficiently to grow biomass that removes carbon dioxide from the atmosphere.

One of the great mysteries in physics has been the quantum Hall effect, which is the surprising behavior of electric currents under certain conditions to change in a stepwise fashion rather than smoothly. On page 50, mathematician Spyridon Michalakis tells us how he helped to solve the problem using a field of mathematics called topology, which studies the fundamental properties of shapes.

Thank you for reading *Scientific American*, and I hope you all are having a safe and healthy summer with plenty of opportunities to enjoy the shade of an oak tree. ■

BOARD OF ADVISERS

Leslie C. Aiello

President, Wenner-Gren Foundation for Anthropological Research

Robin E. Bell

Research Professor, Lamont-Doherty Earth Observatory, Columbia University

Emery N. Brown

Edward Hood Taplin Professor of Medical Engineering and of Computational Neuroscience, M.I.T., and Warren M. Zapol Professor of Anesthesia, Harvard Medical School

Vinton G. Cerf

Chief Internet Evangelist, Google

Emmanuelle Charpentier

Scientific Director, Max Planck Institute for Infection Biology, and Founding and Acting Director, Max Planck Unit for the Science of Pathogens

George M. Church

Director, Center for Computational Genetics, Harvard Medical School

Rita Colwell

Distinguished University Professor, University of Maryland College Park and Johns Hopkins Bloomberg School of Public Health

Kate Crawford

Director of Research and Co-founder, AI Now Institute, and Distinguished Research Professor, New York University, and Principal Researcher, Microsoft Research New York City

Drew Endy

Professor of Bioengineering, Stanford University

Nita A. Farahany

Professor of Law and Philosophy, Director, Duke Initiative for Science & Society, Duke University

Edward W. Felten

Director, Center for Information Technology Policy, Princeton University

Jonathan Foley

Executive Director, Project Drawdown

Jennifer A. Francis

Senior Scientist, Woods Hole Research Center

Harold "Skip" Garner

Executive Director and Professor, Primary Care Research Network and Center for Bioinformatics and Genetics, Edward Via College of Osteopathic Medicine

Michael S. Gazzaniga

Director, Sage Center for the Study of Mind, University of California, Santa Barbara

Carlos Gershenson

Research Professor, National Autonomous University of Mexico

Alison Gopnik

Professor of Psychology and Affiliate Professor of Philosophy, University of California, Berkeley

Lene Vestergaard Hau

Mallinckrodt Professor of Physics and of Applied Physics, Harvard University

Hopi E. Hoekstra

Alexander Agassiz Professor of Zoology, Harvard University

Ayana Elizabeth Johnson

Founder and CEO, Ocean Collectiv

Christof Koch

Chief Scientist, MindScope Program, Allen Institute for Brain Science

Morten L. Kringelbach

Associate Professor and Senior Research Fellow, The Queen's College, University of Oxford

Robert S. Langer

David H. Koch Institute Professor, Department of Chemical Engineering, M.I.T.

Meg Lowman

Director and Founder, TREE Foundation, Rachel Carson Fellow, Ludwig Maximilian University Munich, and Research Professor, University of Science Malaysia

John Maeda

Global Head, Computational Design + Inclusion, Automatic, Inc.

Satyajit Mayor

Senior Professor, National Center for Biological Sciences, Tata Institute of Fundamental Research

John P. Moore

Professor of Microbiology and Immunology, Weill Medical College of Cornell University

Priyamvada Natarajan

Professor of Astronomy and Physics, Yale University

Donna J. Nelson

Professor of Chemistry, University of Oklahoma

Robert E. Palazzo

Dean, University of Alabama at Birmingham College of Arts and Sciences

Rosalind Picard

Professor and Director, Affective Computing, M.I.T. Media Lab

Carolyn Porco

Leader, Cassini Imaging Science Team, and Director, CICLOPS, Space Science Institute

Lisa Randall

Professor of Physics, Harvard University

Martin Rees

Astronomer Royal and Professor of Cosmology and Astrophysics, Institute of Astronomy, University of Cambridge

Daniela Rus

Andrew (1956) and Erna Viterbi Professor of Electrical Engineering and Computer Science and Director, CSAIL, M.I.T.

Eugenie C. Scott

Chair, Advisory Council, National Center for Science Education

Terry Sejnowski

Professor and Laboratory Head of Computational Neurobiology Laboratory, Salk Institute for Biological Studies

Meg Urry

Israel Munson Professor of Physics and Astronomy, Yale University

Michael E. Webber

Co-director, Clean Energy Incubator, and Associate Professor, Department of Mechanical Engineering, University of Texas at Austin

George M. Whitesides

Professor of Chemistry and Chemical Biology, Harvard University

Amie Wilkinson

Professor of Mathematics, University of Chicago

Anton Zeilinger

Professor of Quantum Optics, Quantum Nanophysics, Quantum Information, University of Vienna



April 2020

STARS ON THE MOVE

In “New View of the Milky Way,” Mark J. Reid and Xing-Wu Zheng state that they “find that the sun circles the Milky Way every 212 million years. To put this in perspective, the last time our solar system was in this part of the Milky Way, dinosaurs roamed the planet.” But because the rest of the stars in our galaxy are also moving in the same direction about the center, shouldn’t we “always” be in the same place with respect to them?

DANIEL PANKRATZ
Huntington Beach, Calif.

The spiral of the Milky Way has persisted for billions of years—which means its outermost stars must be moving faster! Since Isaac Newton, we have known that outer objects move more slowly. How do you explain the persistent spiral?

MARK DORMANN *Palm Coast, Fla.*

THE AUTHORS REPLY: Pankratz is conceptually right. The analogy we gave was simply to put the orbital period into perspective. To address his question in more detail: most stars orbit the Milky Way with a circular speed within about 10 percent of that of the sun. Because the circumference of the sun’s galactic orbit is about 50,000 parsecs, or nearly 170,000 light-years, after one galactic orbit, a typical star would be about 5,000 parsecs ahead of, or behind, the sun. So after a 212-million-year orbit,

“Because I check every box of privilege, I have been free to live less cautiously. My duty is to listen more carefully and hear others more fully.”

JIM EYCHANER SACRAMENTO, CALIF.

we would be in the company of totally different neighbors.

Dormann raises a question that puzzled astronomers long ago. We now know that because of dark matter, which extends well beyond where most stars are, the outermost stars are actually orbiting at about the same speed as the sun.

That said, the orbital circumference is larger farther from the center, so the outermost stars have longer orbital periods than those closer to it. This arrangement could lead to spiral patterns winding tighter over time. The answer to the “winding problem” is controversial, but it probably involves patterns rotating slower than the stars or patterns that are short-lived and re-form continuously.

WOMEN IN SURGERY

Chethan Sathya’s observations on the challenges of both discrimination and harassment faced by women surgeons in “Stand Up for Female Surgeons” [Forum] are noteworthy. Behavioral change is critical if we are to address workplace cultures that allow gender and other forms of inequality to persist.

Now more than ever, the need for every physician in every health system to be fully engaged, valued and productive is obvious. Patients around the world need all of us working at the top of our game and collaborating with one another to deliver the care that they require today. More important, society needs the diverse views that each one of us brings to the urgent work of redesigning our system of health care delivery to adapt to our rapidly changing world.

Our experience shows that systemati-

cally addressing barriers to recruitment, retention and leadership participation is an essential starting point and that more can be done to improve well-being in the workplace for surgeons and their families. But teamwork is integral to our business. For generations, women surgeons have valued the same goals as men: delivering patient-centered care, experiencing the challenges and joys of operative surgery, and undertaking the lifelong pursuit of academic inquiry.

It’s time for all of us to work together to build a better health service where everyone’s contribution is valued.

DEBORAH MCNAMARA *National Clinical Program in Surgery, Royal College of Surgeons in Ireland*

REDEFINING RISK

In “Who’s Rational about Risk?” [Observatory], Naomi Oreskes notes that white men and scientists are less concerned than others about the risks of technology.

Viewing the issue with an awareness of the pervasive racism and sexism in American society might help our understanding. Because I check every box of privilege, I have been free to live less cautiously than friends who are not white or male or heterosexual. Now it is a deep-seated habit. My duty to the common good, however, is to listen more carefully and hear others more fully.

JIM EYCHANER *Sacramento, Calif.*

Although it was not her principal purpose in the piece, Oreskes makes a very good case for openness in decision-making about risks in general. What she does not do is to discuss the analytical methods used in risk assessment.

I spent much of my career as an economist for the British government. One of the topics in which I had quite a lot of involvement was the economics of flood risk management (FRM). In England, significant FRM projects are routinely subject to cost-benefit analysis (CBA), in which flood risks, and how they might be expected to change following the introduction of a project, are quantified. Perhaps more important, the business cases for FRM projects are subject to judicial review and thereby to public scrutiny.

One notable component of this kind of

SCIENTIFIC AMERICAN

ESTABLISHED 1845

EDITOR IN CHIEF
Laura Helmuth

MANAGING EDITOR **Curtis Brainard** COPY DIRECTOR **Maria-Christina Keller** CREATIVE DIRECTOR **Michael Mrak**

EDITORIAL

CHIEF FEATURES EDITOR **Seth Fletcher** CHIEF NEWS EDITOR **Dean Visser** CHIEF OPINION EDITOR **Michael D. Lemonick**

FEATURES

SENIOR EDITOR, SUSTAINABILITY **Mark Fischetti** SENIOR EDITOR, SCIENCE AND SOCIETY **Madhushree Mukerjee**
SENIOR EDITOR, CHEMISTRY / POLICY / BIOLOGY **Josh Fischman** SENIOR EDITOR, TECHNOLOGY / MIND **Jen Schwartz**
SENIOR EDITOR, SPACE / PHYSICS **Clara Moskowitz** SENIOR EDITOR, EVOLUTION / ECOLOGY **Kate Wong**

NEWS

SENIOR EDITOR, MIND / BRAIN **Gary Stix** ASSOCIATE EDITOR, SUSTAINABILITY **Andrea Thompson**
SENIOR EDITOR, SPACE / PHYSICS **Lee Billings** ASSOCIATE EDITOR, HEALTH AND MEDICINE **Tanya Lewis**
ASSOCIATE EDITOR, TECHNOLOGY **Sophie Bushwick** ASSISTANT NEWS EDITOR **Sarah Lewin Frasier**

MULTIMEDIA

SENIOR EDITOR, MULTIMEDIA **Jeffery DelViscio** SENIOR EDITOR, MULTIMEDIA **Steve Mirsky**
SENIOR EDITOR, AUDIENCE ENGAGEMENT **Sunya Bhutta** SENIOR EDITOR, COLLECTIONS **Andrea Gawrylewski**

ART

ART DIRECTOR **Jason Mischka** SENIOR GRAPHICS EDITOR **Jen Christiansen**
PHOTOGRAPHY EDITOR **Monica Bradley** ART DIRECTOR, ONLINE **Ryan Reid**
ASSOCIATE GRAPHICS EDITOR **Amanda Montañez** ASSISTANT PHOTO EDITOR **Liz Tormes**

COPY AND PRODUCTION

SENIOR COPY EDITORS **Daniel C. Schlenoff, Aaron Shattuck, Angeliqe Rondeau**
MANAGING PRODUCTION EDITOR **Richard Hunt** PREPRESS AND QUALITY MANAGER **Silvia De Santis**

CONTRIBUTORS

EDITORS EMERITI **Mariette DiChristina, John Rennie**
EDITORIAL **Gareth Cook, Katherine Harmon Courage, Lydia Denworth, Ferris Jabr, Anna Kuchment, Robin Lloyd, Melinda Wenner Moyer, George Musser, Ricki L. Rusting, Dava Sobel, Claudia Wallis**
ART **Edward Bell, Zoë Christie, Lawrence R. Gendron, Nick Higgins, Katie Peek, Beatrix Mahd Soltani**
EDITORIAL ADMINISTRATOR **Ericka Skirpan** EXECUTIVE ASSISTANT SUPERVISOR **Maya Harty**

SCIENTIFIC AMERICAN CUSTOM MEDIA

MANAGING EDITOR **Cliff Ransom** CREATIVE DIRECTOR **Wojtek Urbanek**
MULTIMEDIA EDITOR **Kris Fatsy** MULTIMEDIA EDITOR **Ben Gershman**
ENGAGEMENT EDITOR **Dharmesh Patel**

PRESIDENT

Dean Sanderson

EXECUTIVE VICE PRESIDENT **Michael Florek** VICE PRESIDENT, COMMERCIAL **Andrew Douglas**
VICE PRESIDENT, MAGAZINES, EDITORIAL AND PUBLISHING **Stephen Pincock** PUBLISHER AND VICE PRESIDENT **Jeremy A. Abbate**

CLIENT MARKETING SOLUTIONS

MARKETING DIRECTOR, INSTITUTIONAL PARTNERSHIPS AND CUSTOMER DEVELOPMENT **Jessica Cole**
PROGRAMMATIC PRODUCT MANAGER **Zoya Lysak**
DIRECTOR, INTEGRATED MEDIA **Matt Bondlow**
BUSINESS DEVELOPMENT **Stan Schmidt**
HEAD, PUBLISHING STRATEGY **Suzanne Fromm**
SENIOR ADMINISTRATOR, EXECUTIVE SERVICES **May Jung**

CONSUMER MARKETING & PRODUCT

DEVELOPMENT TEAM LEAD **Raja Abdulhaq**
SENIOR MARKETING MANAGER **Christopher Monello**
PRODUCT MANAGERS **Ian Kelly, John Murren**
SENIOR WEB PRODUCER **Jessica Ramirez**
SENIOR UX DESIGNER **Denise McDermott**
SENIOR COMMERCIAL OPERATIONS COORDINATOR **Christine Kaelin**
MARKETING & CUSTOMER SERVICE ASSISTANT **Justin Camera**

ANCILLARY PRODUCTS

ASSOCIATE VICE PRESIDENT, BUSINESS DEVELOPMENT **Diane McGarvey**
CUSTOM PUBLISHING EDITOR **Lisa Pallatroni**
RIGHTS AND PERMISSIONS MANAGER **Felicia Ruocco**

CORPORATE

HEAD, COMMUNICATIONS, USA **Rachel Scheer**
PRESS MANAGER **Sarah Hausman**

PRINT PRODUCTION

PRODUCTION CONTROLLER **Madelyn Keyes-Milch** ADVERTISING PRODUCTION CONTROLLER **Dan Chen**

LETTERS TO THE EDITOR

Scientific American, 1 New York Plaza, Suite 4600, New York, NY 10004-1562 or editors@sciam.com
Letters may be edited for length and clarity. We regret that we cannot answer each one.
Join the conversation online—visit *Scientific American* on Facebook and Twitter.

HOW TO CONTACT US

Subscriptions

For new subscriptions, renewals, gifts, payments, and changes of address: U.S. and Canada, 800-333-1199; outside North America, 515-248-7684 or scacustserv@cdsfulfillment.com

Submissions

To submit article proposals, follow the guidelines at www.ScientificAmerican.com. Click on "Contact Us."

We cannot return and are not responsible for materials delivered to our office.

Reprints

To order bulk reprints of articles (minimum of 1,000 copies): RandP@sciam.com. Reprint Department, Scientific American, 1 New York Plaza, Suite 4600, New York, NY 10004-1562; 212-451-8415.
For single copies of back issues: 800-333-1199.

Permissions

For permission to copy or reuse material: Permissions Department, Scientific American, 1 New York Plaza, Suite 4600, New York, NY 10004-1562; RandP@sciam.com; www.ScientificAmerican.com/permissions. Please allow three to six weeks for processing.

Advertising

www.ScientificAmerican.com has electronic contact information for sales representatives of Scientific American in all regions of the U.S. and in other countries.

appraisal is the determination of who benefits and who bears the costs and risks involved in a project. In recent years a variant of CBA known as risk-benefit analysis (RBA) has evolved for use in cases where the assessment of risk is a key component. Methodologically, it has much in common with CBA, although, as its name implies, the emphasis on risk assessment tends to be more pronounced.

Personally, I have always been a firm believer in the merits of openness in government. I hope the methods I've described indicate one way in which this can be achieved where risk assessment is a key analytical component in decision-making.

JOHN CORKINDALE *Surrey, England*

SOCIETAL HEALTH

As a medical doctor, I thank you for publishing the excellent commentary on "What's Missing from Medical Training," by Erin Paquette and Angira Patel [Forum, March]. To help improve our public's health, I think we need more such articles published, read and understood by a greater number of people. Good-quality health care does call for tackling health problems at their roots. More providers must go "upstream" to advocate for improving fairness and equity in opportunities for better well-being through social determinants of health in all aspects of society. Not doing so leaves medical interventions unfinished and communities frustrated—and will mean society cannot reach its full capacity to thrive.

ÁLVARO GARZA *via e-mail*

ERRATA

"Future Fossils," by Rachel Nuwer [Advances], should have said that people and livestock make up 96 percent of all mammals' biomass rather than 96 percent of all mammals.

Andrea Gawrylewski's review of *The Human Planet* [Recommended] should have referred to the South Pole rather than the southern tip of Antarctica.

"Landing on the Right Foot," by Leslie Nemo [Advances, June], includes a map illustration with an incorrect key. It should have indicated that U.S. states shown in blue use the "U.S. survey foot" and that those set in pink use the "international foot."

Black Health Matters

The coronavirus has killed a disproportionate number of people of color in the U.S. There are ways to reduce the harm

By the Editors

The U.S. has been roiled this year by two crises that seem on the surface to be unrelated: the coronavirus pandemic and law-enforcement killings of black Americans—the latter leading to mass protests and police violence toward protesters. Although the immediate causes of these two tragedies seem distinct, both have their roots in structural racism. The virus has killed a disproportionate number of black people (as well as other people of color), and black people are by some estimates 2.5 times more likely than white people to be killed by the police. Support is building for police reform, and we can take concrete steps immediately to protect the health of black Americans.

Deep health inequities have always existed in the U.S., but the pandemic has shone an especially harsh light on them. A report from the Centers for Disease Control and Prevention on a sample of 580 people hospitalized with confirmed cases of COVID-19 found that 33 percent of patients were black in a population sample where just 18 percent of the people were black. White people made up 59 percent of the same population, but only 45 percent were infected. Through April 16 in New York City, the death rate among blacks was 92 per 100,000 people and among Latinx people 74 per 100,000—whereas the numbers for white people and Asian people were 45 and 35 per 100,000, respectively. These trends are not limited to New York: the coronavirus has infected and killed an outsize number of black people across the U.S.

Many people of color work in so-called essential industries such as nursing or home health care, grocery stores and mass transit, where they are more likely to come into close contact with people who are sick. To make matters worse, these jobs are often poorly paid, and a large proportion of such workers lack health or life insurance. In addition, many black, Latinx and indigenous communities have high rates of underlying health conditions, including diabetes, hypertension and heart disease, which are known risk factors for severe illness and death from COVID-19. These disparities can be traced back largely to the racism and redlining that have resulted in poor, overcrowded housing and exposed people of color to more severe levels of air pollution—factors that exacerbate all these health problems. The Families First Coronavirus Response Act and the Coronavirus Aid, Relief, and Economic Security (CARES) Act, both of which Congress passed in March, did very little to protect the health of essential workers, according to policy experts across the political spectrum, because they focused more on providing economic relief than medical care or benefits.



Tackling these health inequalities fully will require major reforms in our health insurance system and a true effort to address deep-seated racial and economic injustices. Some possible short-term solutions are out there: the nonpartisan Brookings Institution published a report in March that called for enrolling all uninsured frontline essential workers and their families in a new “Medicare COVID” program that would cover all testing, treatment and vaccinations related to COVID-19. (The CARES Act mandates that insurance providers cover COVID-19 testing but not treatment.)

A proposal from the progressive advocacy group Center for American Progress (CAP) asks for hazard pay for essential workers and paid medical or family leave for workers to care for themselves or a sick family member (the Families First legislation included a provision for two weeks’ paid sick leave but was full of exemptions, mostly for large businesses and health care providers). CAP also called for Congress to ensure coverage for COVID-19 testing and treatments, regardless of immigration status. The House recently passed a \$3-trillion bill that would include many of these provisions, but the legislation appears doomed in the Senate.

We should adopt these measures as a stopgap. But in the long term, we need to expand access to affordable health care for all Americans, and it should not be tied to employment. The Affordable Care Act (ACA) has made great strides toward this end and has proved popular with most Americans, despite Republican efforts to dismantle it. At minimum, we need to reopen ACA enrollment in every state and provide incentives for all states to expand Medicaid, which insures about 75 million low-income Americans.

Too many people of color lack access to even the most basic health care, and others risk losing coverage for themselves and their families if they lose their jobs. The next time there is a pandemic—and there will be a next time—we cannot allow the same appalling racial disparities to determine who lives and who dies. ■

JOIN THE CONVERSATION ONLINE

Visit *Scientific American* on Facebook and Twitter or send a letter to the editor: editors@sciam.com

From Genius to Madness

Discover new insights into neuroscience, human behavior and mental health with six issues of *Scientific American Mind* per year.

sciam.com/mind-digital





Masks and Emasculation

Why some male leaders won't take COVID-19 safety precautions

By Peter Glick

In April, Vice President Mike Pence violated COVID-19 safety protocols at the Mayo Clinic in Minnesota, refusing to don a mask when he toured the hospital. In May, President Donald Trump similarly eschewed a mask—while visiting a mask-making facility. Pence said he wanted to look health care workers in the eye, even though masks don't cover the eyes. Trump has simply said more than once that he is choosing not to do it.

Why? Because “real men” don't play it safe. It's a prescription that, data show, leads men more than women to resist seat belts, take greater physical risks and suffer accidental death at much higher rates. Research has demonstrated that society treats masculinity as an earned status, hard won and easily lost. And the coronavirus has laid bare how some male leaders value projecting a tough guy image over promoting the common good. They defy experts' warnings about the danger they pose to other people susceptible to the virus.

During the coronavirus pandemic, leaders focused on defending a macho image have put their nations at risk in two ways. First, the words and actions of public figures influence their followers through a phenomenon known as social modeling. In Brazil, cell-phone data revealed decreased social distancing after President Jair Bolsonaro dismissed the COVID-19 pandemic. In the U.S., Trump's tweets have encouraged resistance to stay-at-home



Peter Glick is Henry Merritt Wriston Professor of the Social Sciences at Lawrence University and a senior scientist at the NeuroLeadership Institute.

orders. When leaders fail to endorse safety precautions or actively mock them, fewer people take those precautions.

The second way, indicated by my research with Jennifer Berdahl and Natalya Alonso, is that when leaders endorse hypermasculine norms, poor decisions and organizational dysfunction follow. In research with nearly 2,000 participants, we validated something called the masculinity contest culture scale, which asks subjects to agree or disagree with certain norms that assess whether organizational cultures reward toxic male behavior.

Consider two such norms. The first, “show no weakness,” includes the ideas that admitting you don't know the answer and that seeking others' advice are seen as weak. Trump's resistance to expert opinion and his “I alone can fix it” attitude exemplify this attitude. When leaders see listening to experts as undermining their masculinity, science fails to translate into policy.

Another norm, “dog-eat-dog competition” (assessed by items such as “you're either 'in' or you're 'out'” and “you've got to watch your back”), represents the core of the masculinity contest. Every situation is a zero-sum game, promoting suspicion, refusal to admit mistakes, demands for total loyalty and score settling. The result: A win-or-die culture where co-workers constantly compete rather than collaborate. For example, Trump has threatened to withhold critical supplies from states whose governors criticize him.

The pandemic has unmasked the dangers of this type of behavior among national leaders. Trump, reportedly a germaphobe who hates shaking hands even in the best of times, downplayed the virus and continued to press the flesh well into March. In the U.K., Prime Minister Boris Johnson similarly insisted on handshakes as the coronavirus spread, leading the *Guardian* to label him a “super spreader” weeks before he fell ill with COVID-19 and spent days in the hospital. Bolsonaro, who bragged that his athleticism would insulate him from the virus, continues to wade into crowds, shaking hands and hugging supporters. All three minimized the pandemic when it first spread across their countries. In contrast, countries with female leaders—New Zealand and Germany, for example—have generally done better, by empowering scientific experts and supporting prevention measures.

It's important to note that not all male leaders value a macho image over saving lives. For example, Captain Brett Crozier, who commanded the U.S. aircraft carrier *Theodore Roosevelt*, prioritized sailors' well-being when coronavirus broke out. He persisted in seeking help after facing delays and opposition to his request to evacuate and quarantine the crew. Relieved of his post, he was cheered by his crew as he departed his ship. Similarly, New York Governor Andrew Cuomo has focused on the communal goal, doing whatever it takes to minimize COVID-19 deaths.

Effective leadership comes from commitment to the mission. Unfortunately, in the current coronavirus crisis, Trump's continuing need to ignore the advice of experts to show that he is some sort of tough guy harms us all. ■

JOIN THE CONVERSATION ONLINE

Visit *Scientific American* on Facebook and Twitter or send a letter to the editor: editors@sciam.com

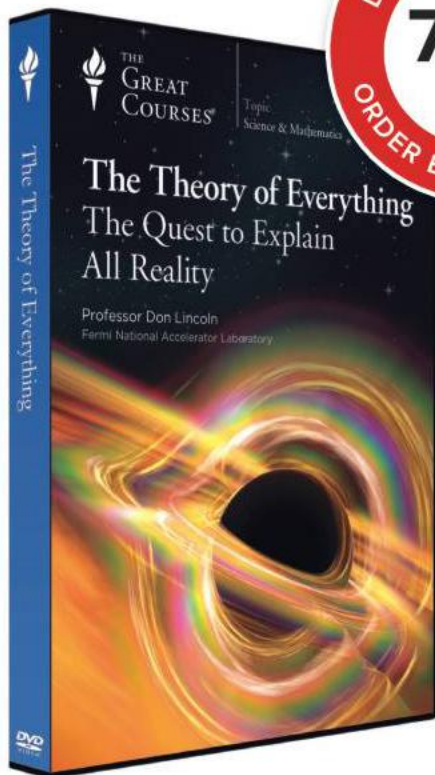

Join the Quest to Explain Everything There Is

At the end of his career, Albert Einstein was pursuing a dream far more ambitious than the theory of relativity. He was trying to find an equation that explained all physical reality—a theory of everything. He failed, but others have taken up the challenge in a remarkable quest that is shedding light on unsuspected secrets of the cosmos.

Experimental physicist and award-winning educator Dr. Don Lincoln of the world-renowned Fermi National Accelerator Laboratory takes you on this exciting journey in **The Theory of Everything: The Quest to Explain All Reality**. Ranging across time and space, and at scales ranging from the subatomic to the cosmic—and even into extra dimensions, with these 24 lectures you will bridge the eras between classical and modern physics and get a glimpse of the goal that has motivated physicists for centuries. It's a dazzling trip!

Offer expires 09/07/20

THEGREATCOURSES.COM/9SA
1-800-832-2412

The Theory of Everything: The Quest to Explain All Reality

Taught by Professor Don Lincoln
FERMI NATIONAL ACCELERATOR LABORATORY

LECTURE TITLES

1. Two Prototype Theories of Everything
2. The Union of Electricity and Magnetism
3. Particles and Waves: The Quantum World
4. Einstein Unifies Space, Time, and Light
5. Relativistic Quantum Fields and Feynman
6. Neutrinos Violating Parity and the Weak Force
7. Flavor Changes via the Weak Force
8. Electroweak Unification via the Higgs Field
9. Quarks, Color, and the Strong Force
10. Standard Model Triumphs and Challenges
11. How Neutrino Identity Oscillates
12. Conservation Laws and Symmetry: Emmy Noether
13. Theoretical Symmetries and Mathematics
14. Balancing Force and Matter: Supersymmetry
15. Why Quarks and Leptons?
16. Newton's Gravity Unifies Earth and Sky
17. Einstein's Gravity Bends Space-Time
18. What Holds Each Galaxy Together: Dark Matter
19. What Pushes the Universe Apart: Dark Energy
20. Quantum Gravity: Einstein, Strings, and Loops
21. From Weak Gravity to Extra Dimensions
22. Big Bang and Inflation Explain Our Universe
23. Free Parameters and Other Universes
24. Toward a Final Theory of Everything

The Theory of Everything:
The Quest to Explain All Reality
Course no. 1318 | 24 lectures (30 minutes/lecture)

SAVE UP TO \$200

DVD ~~\$269.95~~ **NOW \$69.95**
Instant Video ~~\$234.95~~ **NOW \$49.95**

+\$10 Shipping & Processing (DVD only)
and Lifetime Satisfaction Guarantee

Priority Code: 182647

For over 30 years, The Great Courses has brought the world's foremost educators to millions who want to go deeper into the subjects that matter most. No exams. No homework. Just a world of knowledge available anytime, anywhere. Download or stream to your laptop or PC, or use our free apps for iPad, iPhone, Android, Kindle Fire, or Roku. Over 700 courses available at www.TheGreatCourses.com.

ADVANCES

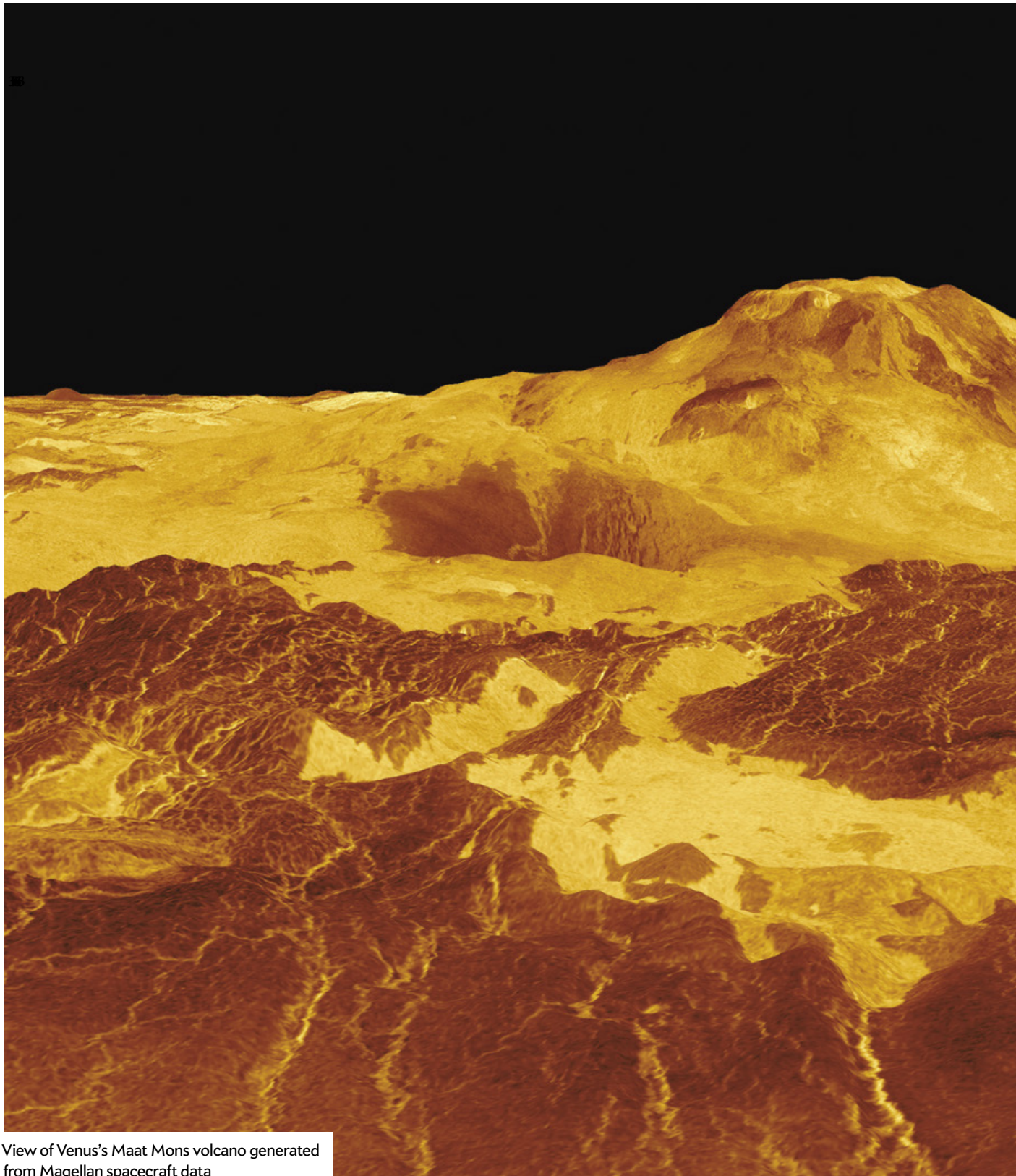

View of Venus's Maat Mons volcano generated from Magellan spacecraft data

- A region's organic history, writ in vivid red stalagmites
- Entomological lidar detects clouds of mosquitoes and other fliers
- A strange trick lets the brain quickly pinpoint objects
- Paved surfaces worsen flooding

PLANETARY SCIENCE

Toxic Transformation

How Venus might have changed from habitable to harsh

Below Venus's toxic clouds of sulfuric acid is an apocalyptic world, with temperatures hot enough to melt lead and pressures that could crush heavy machinery. But it might not always have been so.

In 2016 Michael Way of NASA's Goddard Institute for Space Studies and his colleagues applied the first three-dimensional climate model to early Venus. *They found* it could once have been so temperate that liquid water pooled in vast oceans—the key to life as we know it. Now Way and Anthony Del Genio, also at Goddard, have developed a framework for the planet's evolution based on more complex data that incorporates various topographies and different amounts of sunlight. Their study, published in May in the *Journal of Geophysical Research: Planets*, puts forward a new explanation for how Venus could have remained habitable for nearly three billion years before morphing into today's blistering hellscape.

Many scientists have postulated that Venus was bone-dry from the beginning and never hosted liquid water. Roughly 4.5 billion years ago, when the solar system formed, the second planet from the sun would have received enough sunlight that any atmospheric water was lost to space—and the radiation would have thwarted the formation of life as it exists on Earth. "There would have been nothing," Way says, without some mitigating factor. That factor, he and Del Genio argue, could have been a supersized cloud that developed early in the planet's evolution and cooled the world.

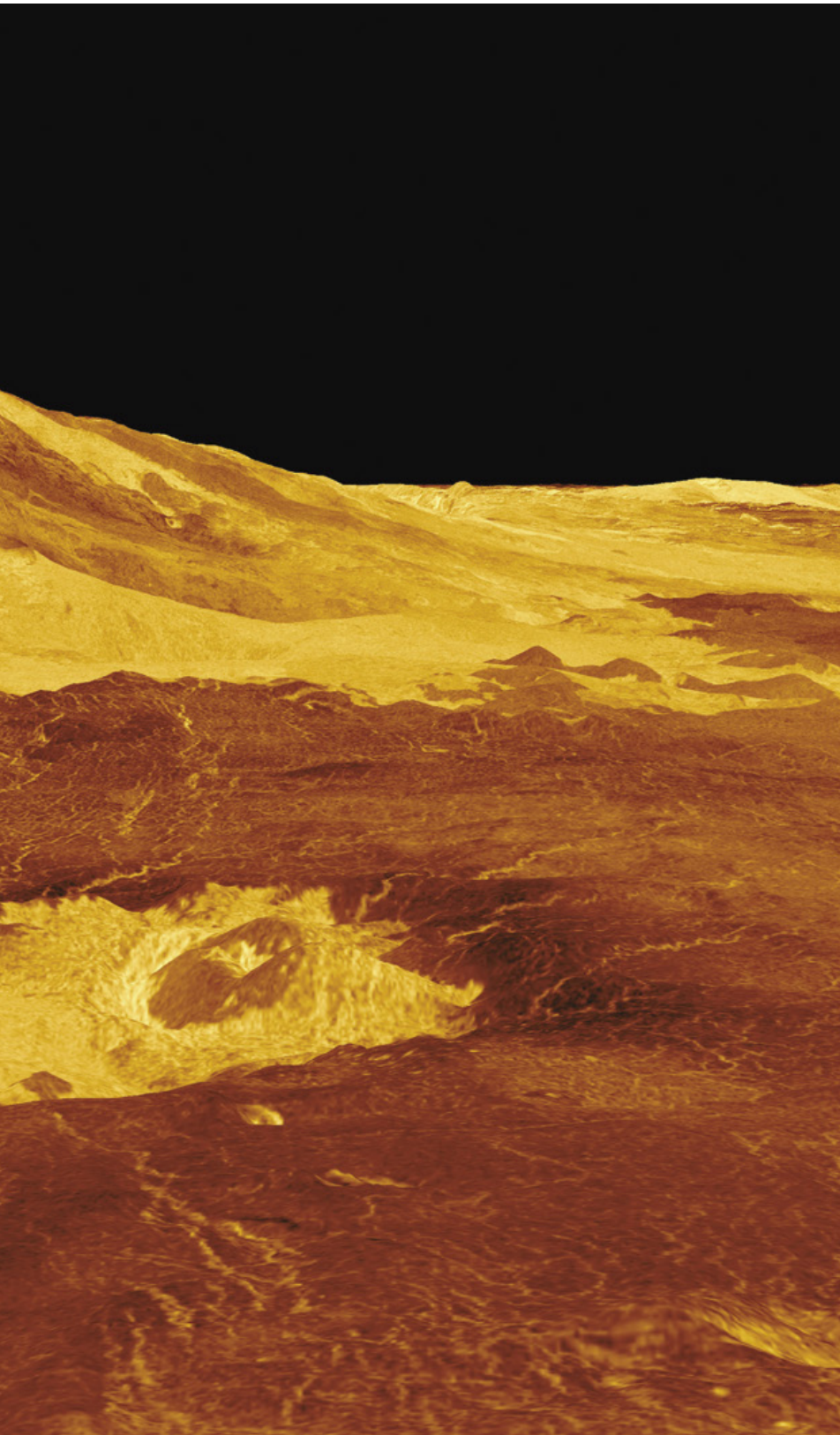

ALAMY

Unlike Earth, Venus does not rotate once on its axis every 24 hours but instead does so once every 243 Earth days. Given that it orbits the sun on a similar timescale (once every 225 Earth days), one side of the planet typically basks in sunlight, while the other faces a lengthy darkness. A thick atmosphere could easily circulate heat from the dayside to the nightside, keeping Venus hot. But in Way and Del Genio's model, a giant cloud on the dayside would act as a bright shield to reflect incoming sunlight and allow temperatures cool enough for liquid water.

Many researchers have already considered the idea that Venus was once habitable, but the new model further shows how the planet could have transformed into today's hothouse—and it tosses conventional wisdom aside. “There’s a story about Venus that we tell ourselves. We teach it in introductory astronomy classes, and we write about it in books,” says David Grinspoon, an astrobiologist at the Planetary Science Institute, who was not

involved in the study, although he was a co-author on the 2016 paper. “And it turns out that story is wrong.” The idea is that the sun slowly increased in brightness, causing the planet to grow so warm that it could no longer maintain a stable ocean. In other words, it pushed the inner edge of the so-called habitable zone—the orbital region where liquid water can create conditions conducive to life—past the solar system’s second planet. But Way and Del Genio’s model suggests cloud cover would have provided enough shade to keep liquid water on the surface of Venus even until today—had something not tipped the planet into its current state.

The authors propose a violent mechanism best understood by looking at the young Earth. Roughly 250 million years ago deep gashes opened in Earth’s crust, pouring lava onto the surface and spewing enough carbon dioxide into the atmosphere to kill 96 percent of marine species and 70 percent of terrestrial species in the larg-

est mass extinction in history. These volcanic events, which leave deposits called large igneous provinces, produce at least 100,000 cubic kilometers of lava over one million years. “We’re talking about an affront to God in terms of the amount of lava that comes out per unit time,” says Paul Byrne, a planetary geologist at North Carolina State University, who was not involved in the study.

Although these eruptions have rocked Earth on several occasions, often resulting in mass extinctions, multiple events have never happened at once. “That’s fortunate for life on Earth,” Way says, but scientists see no reason why more than one event could not happen simultaneously. And if such multiple events did occur on Venus, they would have dumped enough carbon dioxide into the atmosphere to drive the planet into an apocalyptic greenhouse state, researchers say.

The hypothesis is attractive: “There’s something romantically tragic about a world so like our own that was killed,” Byrne says. “I want so much for it to be

PALEOSEISMOLOGY

Talking Bones

Buried remains suggest an ancient, destructive tsunami in East Africa

The 2004 Indian Ocean earthquake sent a tsunami surging outward from Sumatra, devastating coastlines across Southeast Asia but doing much less damage by the time it reached Africa. Many scientists have since considered the tsunami risk in parts of East Africa to be relatively low. But new research conducted on a 1,000-year-old sand layer full of human bones, in northeastern Tanzania’s Pangani Bay, puts the threat of a monster wave back in the spotlight.

Supplementing years of fieldwork done by archaeologists at the University of Dar es Salaam, an international group of geologists combined its own sand-layer analysis with computer-simulated earthquake scenarios. The group found evidence that an ancient Pangani Bay fishing settlement was wrecked by a tsunami emanating from the Sumatra-Andaman subduction zone—



Dig site near the Pangani River in Tanzania

which was also the source of the powerful 2004 tsunami. Lead author Vittorio Maselli of Dalhousie University in Nova Scotia was a National Geographic Explorer for the study, published online in May in *Geology*. Within the sand layer the researchers

found evidence of tiny marine fauna swept in from the sea and broken human bones that could not be attributable to disease, violence or traditional burials. “Taking the analysis together, the tsunami was the best interpretation,” Maselli says.

DAVIDE OPPO

true that one day we'll touch down and find fossils from a shallow sea of a Venusian ecosystem." He notes, however, that there is no direct evidence to support this notion.

The authors argue that large-scale volcanism would have continued to pave much of the planet in volcanic rock, a state visible today. But Vicki Hansen, a geologist at the University of Minnesota Duluth, who was not involved in the study, says measurements from the Magellan spacecraft, which orbited Venus in the early 1990s, do not support a resurfacing from one catastrophic event: "If you look at the data, it flies in the face of all that," she says. According to her team's analysis, "We can identify three distinct eras in the evolution of Venus; if you have catastrophic resurfacing, that doesn't work, because [it] would wipe out all earlier histories."

There is no question that the issue is contentious. Indeed, a number of scientists still argue that Venus was never fit for life.

To find out, researchers will need to

peer more closely at our neighbor. "We could do models until the cows come home; that doesn't make anything right," Hansen says. "We have to test what the results of those models are."

Byrne says we should send a fleet of spacecraft to Venus, including orbiters, landers, balloons, aerial platforms and even blimps. The planet's atmosphere holds clues about how much water has been lost, and the surface could reveal whether and when volcanic eruptions punctured it. Future missions could help settle the debate about whether or not Venus was ever hospitable to life and could push astronomers to expand their search for livable planets across the galaxy.

"If this scenario is correct, it says Venus-like planets actually have the potential for life, so we shouldn't ignore them," says Adrian Lenardic, a geophysicist at Rice University, who was also not involved in the research. "We should look there."

—Shannon Hall



This study could provide the first in a series of data points needed to understand the extent of tsunami risk along East Africa's vast coastline of unmapped seafloors and buried sand layers. And it matches evidence elsewhere: on the other side of the

Indian Ocean, researchers have spotted similar tsunami deposits thousands of years old in many of the coastal areas that suffered the heaviest casualties from the 2004 event. "Perhaps the most interesting part [of this study] is that it correlates well with what some of my colleagues had done on the eastern coast of India," says Emile Okal, a seismologist at Northwestern University, who was not involved in the new research. "From a geologic standpoint, I think this is a very nice contribution."

Although more work is needed to fully understand the area's risk, the researchers say their study identifies a very real natural hazard for developers to consider in this rapidly urbanizing region. "To me, the takeaway is for long-term infrastructure projects," says Andrew Moore, a study co-author and a geologist at Earlham College. "This is a call to arms to go look" for tsunami deposits elsewhere.

Additional research can help future East African megacities mitigate risk, Maselli says: "For the moment our knowledge is just one point for the entire African continent. Our claim is, 'Look, we found something ... let's go back to East Africa and learn more.'" —Christian Fogerty

IN SCIENCE WE TRUST

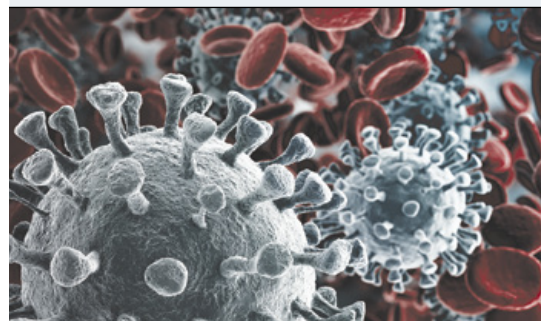

The answers will come from science and reason, not "From Above."

STAY SAFE

Join the nation's largest association of freethinkers (atheists and agnostics) working to keep religion out of government.

Join now or get a FREE trial membership & bonus issues of Freethought Today, FFRF's newspaper.



Call 1-800-335-4021
ffrf.us/science

FREEDOM FROM RELIGION foundation

FFRF.ORG

FFRF is a 501(c)(3) educational charity. Deductible for income tax purposes.

GEOLOGY

Study in Red

Stalagmites rich in organic matter record environments past

Not far from the famously multihued architecture of Bilbao in northern Spain, an underground world boasts its own vibrant display of color. The stalagmites and stalactites of Goikoetxe Cave are not just the usual white; many range from honey to deep red. New research shows that these formations, known generally as speleothems, get their red color from organic compounds leached from soil and transported by water. Scientists suggest, in an article published online in April in *Quaternary International*, that Goikoetxe Cave's speleothems record environmental conditions such as rainfall.

Virginia Martínez-Pillado, a paleoclimatologist at the Atapuerca Research Group and the UCM-ISCIlI Center for Human Evo-

lution and Behavior in Madrid, hiked and crawled through Goikoetxe Cave to reach its *sala roja* ("red chamber"). "All around you is red," Martínez-Pillado says of the cavernous room covered in stalagmites and stalactites. She and her colleagues collected four stalagmites rising from the cave floor and brought them back to the laboratory. The team analyzed trace elements in them and ruled out iron oxidation, which often causes red coloration. (Think Mars.)

A reddish hue can also derive from organic materials, so the scientists next checked the stalagmites' molecular makeup. By measuring how the speleothems scattered and absorbed light, the researchers found that they contained humic and fulvic acids. These complex molecules form from decomposed plant debris, and the team concluded they must have been picked up by water and deposited on the stalagmites as they grew over thousands of years.



Spain's Goikoetxe Cave

The stalagmites could therefore point to past environmental conditions. Changes in rainfall, for instance, would affect the amount of organic matter flushed into the cave, says Alison Blyth, a geochemist at Curtin University in Perth, Australia, who was not involved in the study: "If we measure the chemical signals preserved in each layer, we can reconstruct how different environmental parameters have changed over time." Martínez-Pillado and her colleagues are now analyzing the stalagmites to trace ancient variations in rainfall and vegetation above Goikoetxe Cave. This technique can also be applied to other caves with speleothems rich in organic matter, the researchers say. —Katherine Kornei

ADRIAN SPELEOLOGICAL GROUP

NEUROBIOLOGY

Building with Biology

A novel technique turns brain cells into circuit components

New research could let scientists co-opt biology's basic building block—the cell—to construct materials and structures within organisms. A study, published in March in *Science* and led by Stanford University psychiatrist and bioengineer Karl Deisseroth, shows how to make specific cells produce electricity-carrying (or blocking) polymers on their surfaces. The work could someday allow researchers to build large-scale structures within the body or improve brain interfaces for prosthetic limbs.

In the medium term, the technique may be useful in bioelectric medicine, which involves delivering therapeutic electrical pulses. Researchers in this area have long been interested in incorporating polymers that conduct or inhibit electricity without damaging surrounding tissues. Stimulating specific cells—to intervene in a seizure, for instance—is much more precise than flooding the whole organism with drugs,

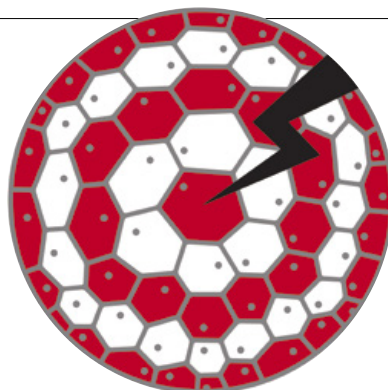

which can cause broad side effects. But current bioelectric methods, such as those using electrodes, still affect large numbers of cells indiscriminately.

The new technique uses a virus to deliver genes to desired cell types, instructing them to produce an enzyme (Apex2) on their surface. The enzyme sparks a chemical reaction between precursor molecules and hydrogen peroxide, infused in the space between cells; this reaction causes the precursors to fuse into a polymer on the targeted cells. "What's new here is the intertwining of various emerging fields in one application," says University of Florida biomedical engineer Kevin Otto, who was not involved in the research but co-authored an accompanying commentary in *Science*. "The use of conductive polymers assembled [inside liv-

ing tissue] through synthetic biology, to enable cell-specific interfacing, is very novel."

The researchers tested the process and tracked cell function in rodent brain cells, artificially grown human brain models, and living worms. They also injected the ingredients into living mice's brains to show they were not toxic.

The commentary authors say this work could pave the way for improved treatments for depression or Parkinson's disease by increasing the precision with which neurons are stimulated. It could also precisely target cells that carry information to the brain, potentially giving amputees sensations in a prosthetic limb.

Deisseroth sees the research having even broader uses. "We've been able to build new structures inside cells we target genetically, so we have only the cells of interest construct something for us; that's pretty exciting and very, very general," he says. "It's a basic science exploration of: What can we do? What can we build within biological structures using their structural complexity?"

Obstacles remain, however. "There are regulatory hurdles associated with gene therapy in humans," Otto says. The durability of changes, as well as viability of the technique in higher species, also needs to be demonstrated, he adds. —Simon Makin

IN THE NEWS

Quick Hits

By Sarah Lewin Frasier

CANADA

A new study models how a gigantic, morphing blob of liquid iron in Earth's outer core underneath the Canadian Arctic is losing its grip on the North magnetic pole. A second, intensifying blob below Siberia is pulling the pole away.

SCOTLAND

A geologic-dating effort suggests the fossil of a millipede-like creature found on the island of Kerrera formed 425 million years ago, making it possibly the oldest-known fossilized land animal. (Older land animals have been spotted indirectly, through preserved tracks.)

NORWAY

Archaeologists are excavating a 20-meter Viking ship, buried below a farmer's field, to stop a wood-eating fungus from destroying it. Ground-penetrating radar had found the ship in 2018, and a new wood sample analysis revealed that it could not be preserved underground.

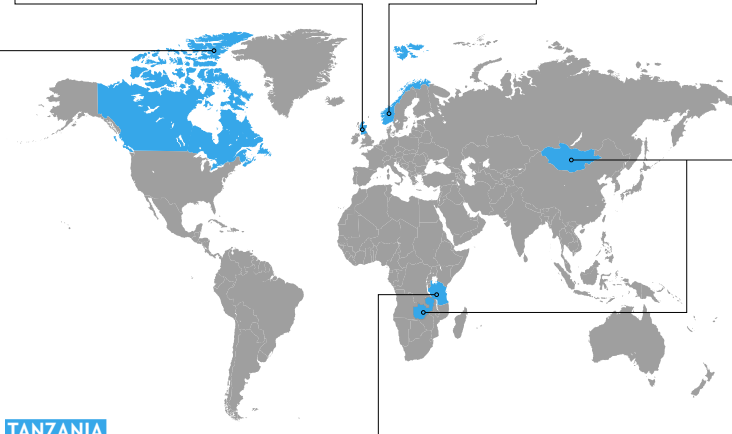

ZAMBIA AND MONGOLIA

This spring a satellite-tagged cuckoo completed an epic 12,000-kilometer journey from Zambia to Mongolia. It had originally been tagged in Mongolia in 2019 and traversed 16 countries in its round-trip migration.

TANZANIA

Researchers discovered Africa's largest-ever collection of fossilized human footprints, left in volcanic mud about 10,000 years ago. Many of them came from a group of 17 people, mostly women, all walking in the same direction.

ANTARCTICA

Scientists found that king penguin excrement releases nitrous oxide—also known as laughing gas. It forms as soil bacteria eat the droppings' nitrogen-rich compounds.

For more details, visit www.ScientificAmerican.com/aug2020/advances.

© 2020 Scientific American

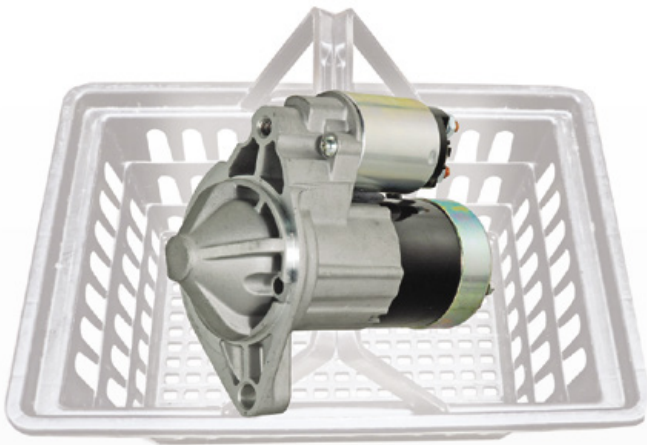

Get this with your money at a typical auto parts store.



Or ALL this at www.RockAuto.com!



- ✓ Reliably Low Prices
- ✓ Easy To Use Website
- ✓ Huge Selection
- ✓ Fast Shipping

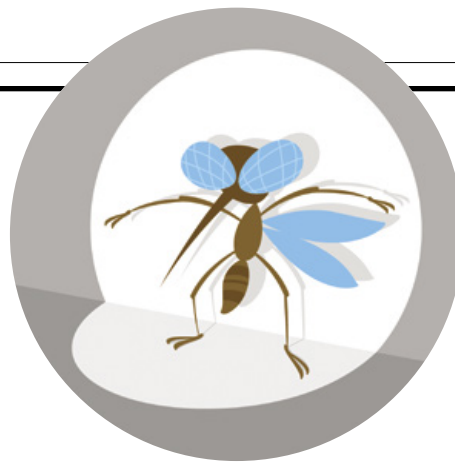

TECH

Mosquito Rush Hour

Lidar advances help to detect mosquito movements

During a 2016 solar eclipse, a team led by researchers at Sweden's Lund University projected a beam of infrared laser light into the darkened Tanzanian sky to measure how insects responded to the unusual twilight. Afterward, the group continued monitoring for another five nights and four days. The laser-based system used, known as lidar, detected more than 300,000 insects during this time.

Many of these bugs were the world's deadliest: the mosquito, one genus of which can carry the parasite that causes half a million malaria deaths every year. During the mosquitoes' morning and evening "rush hour," the researchers measured high numbers of the insects taking flight at nearly the exact same times each day. The eclipse, they found, also summoned a large cloud of mosquitoes. The result suggests that in nature, light levels, rather than circadian rhythms,

dictate mosquitoes' activity. Crucially, the study, published in May in *Science Advances*, also illustrates lidar's potential to assess malaria risk and prevention measures—and to help collect entomological data.

The study marks "the first time that you can classify multiple different types of insects over the field in their natural settings," says lead author and Lund physicist Mikkel Brydegaard.

The study tested an entomological lidar type Brydegaard invented, which is used around the world. In his system, each insect flying through a lidar beam reflects light back into a telescope. The light, called backscatter, can be analyzed to find the frequency of wingbeats, which lets researchers determine the numbers and species of insects passing through. The team was

able to identify mosquitoes, moths, flies and midges—and could even differentiate between male and female mosquitoes.

Scientists fighting malaria often use physical traps to catch mosquitoes at various life stages, then analyze them and their genes in a laboratory. But this method is time-consuming and expensive, and it does not let scientists assess populations over time or evaluate the efficacy of spraying or other control measures in the field.

"With this type of lidar, they're demonstrating with the eclipse and in general that you can actually track the population with much higher accuracy," says New Jersey Institute of Technology physicist Benjamin Thomas, who was not involved in the study but is among a growing number of entomology researchers experimenting with lidar. "You can observe thousands and thousands of insects, finally opening the door to us being able to monitor those populations."

The scientists say lidar installations could raise malaria risk alerts, as a weather station can warn of impending storms. And tracking mosquitoes is just one application of the technology; it could also be used to detect pollinator diversity and monitor pests on farms or in protected areas, Brydegaard says. —Susan Cosier

MEDICINE

Snakebite Pill

A preexisting drug could buy time for treatment

A drug that treats poisoning from heavy metals may also offer a fighting chance at surviving a venomous snakebite. In a study published in May in *Science Translational Medicine*, researchers show that oral doses of the medication can reduce viper venom's effects in mice.

Saw-scaled or carpet vipers are a group of aggressive venomous snake species found in Asia and Africa, including some densely populated regions with limited access to modern medical facilities. "They arguably cause more bites and deaths than any other snake in the world," says Abdulrazaq Habib, an infectious and tropical disease physician at Nigeria's Bayero University Kano, who was not involved in the study. The vipers' venom destroys tissue

around the bite site and sometimes leads to loss of digits, limbs or lives, Habib adds.

This venom contains toxic enzymes called metalloproteinases, which rely on zinc ions to function and can cause tissue damage and internal bleeding. "We hypothesized that capturing these ions may inhibit the toxin's activity and neutralize its harmful effects," says Laura-Oana Albuлесcu, a biochemist at the Liverpool School of Tropical Medicine (LSTM) in England and lead author on the new study. She and her colleagues investigated treatments for poisoning from heavy metals that use compounds to clamp onto loose metal ions. "We hope our study will highlight the promise of repurposing oral treatments as first-line interventions for snakebite—an idea that has been tinkered with before ... but was never fully developed," Albuлесcu says.

The researchers' laboratory tests showed that a family of three promising drugs could inhibit the toxin's activity in venoms from multiple species of saw-scaled vipers. Next they tested each drug

in mice injected with a typically lethal dose of venom from a West African carpet viper. One drug, unithiol, saved all mice when given 15 minutes after venom injection and followed an hour after injection by an anti-venom dose. Neither the drug nor antivenom alone was sufficient to save all the envenomated mice, Albuлесcu says. The results suggest unithiol might work as an early snakebite intervention, buying more time to reach a hospital for treatment. "The findings reported are very promising, and the investigators have explored different practical scenarios," Habib says.

The drug costs much less than antivenom and is already designated safe for other uses, says Nicholas Casewell, a study co-author and venom expert at LSTM. The researchers plan to begin clinical trials in humans early next year to verify the drug's safety and tolerability in African populations, who bear the brunt of viper attacks. Their hope is that within a couple of years unithiol might become the world's first "snakebite pill." —Harini Barath



Loggerhead sea turtle hatchlings

BIOLOGY

Safer Turtle Sexing

A new blood test tells scientists whether hatchlings are male or female

Determining turtle hatchlings' sexes is a challenging but critical task. For many species the embryo's sex development depends on environmental temperatures, and rising heat is producing overabundances of females and shortages of males. Unchecked, this mismatch could push some species toward extinction.

To save them, "you have to really understand where the problems lie," says Jeanette Wyneken, a biologist at Florida Atlantic University and senior author on a new study on the topic, published in March in *Scientific Reports*. Monitoring turtles' sex ratios as hatchlings can help—but species with temperature-dependent sex determination lack sex chromosomes and mature relatively late, making their sexes hard to discover noninvasively.

Wyneken's team developed a blood test that determined the sexes of loggerhead and red-eared slider hatchlings up to two days old with 100 percent accuracy. In older juvenile loggerheads, the results

were 90 percent accurate. The test checked a tiny blood sample for a hormone that prevents young males from developing oviducts. (The hormone takes on additional roles as the turtles grow, Wyneken says, which can complicate results for older females.)

The researchers then used two standard techniques to verify results for the turtles they tested. They analyzed tissue samples from gonads of their 10 red-eared sliders, which were sacrificed as hatchlings, and five loggerheads, which were found dead in their nest boxes. They also raised 54 loggerhead juveniles to between 83 and 177 days old before performing laparoscopic surgeries on the live animals. These surgeries cannot be safely performed on hatchlings, Wyneken says.

The group is working to make the blood test field-ready. The researchers hope to use it to monitor sex ratios in easy-to-catch wild hatchlings and perhaps find ways to intervene in the field, such as providing shade or cooling sprinklers when eggs are incubating. Unlike current methods, which require killing hatchlings or estimating sex ratios based on incubation temperature, the new technique "is a non-lethal and reliable method to determine hatchling sex," says Camryn Allen, a wild-life endocrinologist at the Pacific Island Fisheries Science Center, who was not involved with the study. —Rachel Crowell

ROGER DE LA HARPE/Getty Images

Expertise.
Insights.
Illumination.

12 print issues per year

Archive back to 1845

Read anytime, anywhere

sciam.com/print&archive



Scientific American is a registered trademark of Springer Nature America, Inc. Google Play and the Google Play logo are trademarks of Google LLC. Apple, the Apple logo, iPhone, and iPad are trademarks of Apple Inc., registered in the U.S. and other countries and regions. App Store is a service mark of Apple Inc.

PSYCHOLOGY

Hard to Find

Objects' nonvisible physical traits can help people locate them faster

We spend a substantial part of our days visually scanning an area for something we want—our keys or ketchup, for example. For scientists the way we do so “provides a window into how our minds sift through the information that arrives at our eyes,” says Jason Fischer, a cognitive neuroscientist at Johns Hopkins University. Past research has focused on readily apparent visual characteristics such as color, shape and size. But an object’s intrinsic physical properties—things we know from experience but cannot see, such as hardness—also come into play.

“You may not be able to immediately see that a brick is heavier than a soda can and harder than a piece of cake, but you know it. And that knowledge guides how

you act on a brick as compared with those other objects,” says Fischer, senior author on a new study led by graduate student Li Guo. “We asked whether that knowledge about objects’ hidden physical properties is, in itself, something you can use to locate objects faster.” The study was published online in May in the *Journal of Experimental Psychology: General*.

Researchers asked study participants to pick out the image of an item in a grid of other objects as quickly as possible. Each grid was controlled for the color, size and shape of the objects presented, so participants could not use easy visual cues. For example, when they were asked to find a cutting board, the grid also included softer but similarly colored items such as a croissant and a bandage and similarly shaped items, among them a sponge, pillow and paper bag.

The researchers “found that people automatically used what they knew about an object’s hardness to find it faster,” Fischer says. By tracking participants’ eye move-

ments, the team saw that people spent less time examining objects without the correct hardness. This held even when participants assessed a grid of simplistic black-and-white line drawings in which physical traits were only implied, Guo says.

“When I’m searching for an object, thinking about that object summons up a variety of useful information that my mind will leverage to find it as efficiently as possible,” Fischer explains. “It’s a built-in trick that you can use without any awareness of doing so.”

Vivian C. Paulun, a vision researcher at the University of Giessen in Germany, who was not involved in the study, says it shows that a haptic (touch-based) property can influence visual attention by association. “An obvious next step would be to test whether this effect can be replicated with other mechanical, nonvisual object properties, such as fragility,” Paulun observes. “This would strengthen the evidence that physical object properties guide visual attention.” —*Jillian Kramer*

ENVIRONMENT

Over Paved

Impervious surfaces exacerbate flood levels

Blockbuster flooding events such as Hurricane Harvey grab headlines, but urban flooding is a routine—and growing—problem: in a 2018 report, 83 percent of municipal stormwater and flood managers surveyed in the U.S. reported such inundation in their areas. Although heavier downpours fueled by climate change are a factor, the expansion of pavement and other impervious surfaces is making the situation worse because it prevents the land from absorbing these torrents of water. On that broad point, researchers largely agree. What they have not agreed on is how much worse.

Now a study published in March in *Geophysical Research Letters* has found that, on average across the U.S., every time a city expands roads, sidewalks or parking lots by one percentage point, the annual flood magnitude in nearby waterways increases by 3.3 percent. (Some of the floodwater that the ground cannot absorb runs into nearby rivers and streams, so measuring



their levels can help track changes in flooding severity.) Hydrologist Annalise Blum and her co-authors say the mathematical model they used makes their finding more accurate than previous studies. And the model could help answer other questions about human impacts on water systems—an emerging field called sociohydrology.

Blum says previous research that looked at just one or two waterways was too narrowly focused to parse how much various human interventions such as paved surfaces, dams or levees contribute to flooding. To untangle the role of impervious areas from the “noise” of other influences, Blum and her colleagues—including Paul Ferraro, an economist at Johns Hopkins University—used an extremely large data set covering 39 years of records

from 280 stream gauges, which measure water levels in rivers and streams. They also adapted a statistical model more common to economic studies. Economists use this technique to isolate how a particular policy might alter human behavior. Blum and her team tweaked it to leverage differences among all the stream-gauge data, thus isolating the role of paving from other human modifications. “By using data in both

time and space dimensions, we were able to soak up all of that noise and isolate the causal effect,” says Blum, who was a post-doc at Johns Hopkins when she conducted the new study and is now an AAAS Science & Technology Policy Fellow.

Maura Allaire, a water economist at the University of California, Irvine, who was not involved with the new study, says the research design is “a major contribution to natural sciences and hydrology in particular.” Conducting similar analyses for other human-made contributors to flooding could help cities take targeted steps to ameliorate them. For instance, cities could discourage building in a floodplain if that was shown to be a dominant factor or increase “green” infrastructure and permeable surfaces to absorb more rainwater. —*Erica Gies*

ERIK WITSOE/Getty Images

ADVANCED DIGITAL HEARING AID TECHNOLOGY

BUY 1 GET 1 FREE Reg: ~~\$399.98~~
Only \$199⁹⁹
Each When You Buy a Pair – **LIMITED TIME ONLY!**

How can a **digital hearing aid** that costs only **\$199⁹⁹** be every bit as good as one that sells for \$2,400 or more?

The answer: Although tremendous strides have been made in Advanced Digital Hearing Aid Technology, those cost reductions have not been passed on to you. Until now...

MDHearingAid® uses the same kind of Advanced Digital Hearing Aid Technology incorporated into hearing aids that cost thousands more at a small fraction of the price.

Over 350,000 satisfied **MDHearingAid** customers agree: High-quality, digital FDA-registered hearing aids don't have to cost a fortune. The fact is, you don't need to spend thousands for a digital hearing aid. **MDHearingAid** is a medical-grade digital hearing aid offering sophistication and high performance, and works right out of the box with no time-consuming "adjustment" appointments. You can contact a licensed hearing specialist conveniently online or by phone — even after your purchase at no cost. No other company provides such extensive support. Now that you know...why pay more?

MDHearingAid® >>>

DOCTOR DESIGNED | AUDIOLOGIST TESTED | FDA REGISTERED



SHOP AT HOME!
Skip the Clinic
with Remote Care

"I was amazed! Sounds I hadn't heard in years came back to me!"

— Don W., Sherman, TX

Can a Hearing Aid Delay or Prevent Alzheimer's and Dementia?

A study by the National Institute on Aging suggests older individuals with hearing loss are significantly more likely to develop Alzheimer's and dementia over time than those who retain their hearing. They suggest that an intervention — such as a hearing aid — could delay or prevent this by improving hearing!

45-DAY RISK-FREE TRIAL!

If you are not completely satisfied with your MDHearingAids, return them within 45 days for a FULL REFUND!

For the Lowest Price Call

1-800-319-7176

www.MDBOGO.com

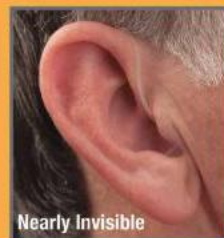

Nearly Invisible

BATTERIES INCLUDED!

Use Code **KC86**
and get **FREE Batteries for 1 Year**
Plus FREE Shipping

Proudly assembled in America!





As the Knud Rasmussen Glacier Calves, a Woman Translates “Gravitational Waves” into Blackfoot

When we first detect the chirp of black holes colliding, she renders the press release into disappearing language:

“Light splitter and union of instruments” (speak, *interferometer*)
 “Self-strengthened lights exploding” (speak, *gamma rays*).

Such subtle “bird songs” are undone by gravitational waves, we are compelled to fix their fugitive features.

In glaciers, nature deviates and also runs its course—
 its layers not quite memory, but more like artifice:
 snow’s structure, changed under so much weight
 the geometry of flakes collapses, heavy cold
 compressing air, deforming firn.

The cold is a formalist: it constructs a made thing, temporary,
 describing ancient climate feedbacks as it melts.

How elusive the object, how we read impermanence in layers
 of ice so compressed
 its expansion can shatter glass
 of ice so deep you can no longer discern *sequence*,
 its layers folding and sliding into the nonlinear,
 as effortful as astrophysics in Siksika,
 somehow still legible.

We must consider and reconsider
 freezing and thawing,
 a girl punished for speaking in her native tongue,
 the defiance in resurrecting an idea whose circumference
 swells and contracts, an artifact of water and sky,
 revealing the dual meanings of *sublime*—
 its magnificence, its vaporizing solidity—
 which, I say, is proof of something, if it doesn’t save us.

AUTHOR’S NOTE: Astrophysicist Corey Gray, a member of the Laser Interferometer Gravitational-wave Observatory (LIGO), asked his mother, Sharon Yellowfly, to translate the LIGO press release on the detection of gravitational waves into Blackfoot.



Claudia Wallis is an award-winning science journalist whose work has appeared in the *New York Times*, *Time*, *Fortune* and the *New Republic*. She was science editor at *Time* and managing editor of *Scientific American Mind*.

The Other U.S. Epidemic

Suicides have been rising.
Will the pandemic make things worse?

By Claudia Wallis

Another epidemic besides COVID-19 stalks the land. This one takes a heavy toll on the young. It has been raging ever more lethally for the past 20 years with no flattening of the curve in sight: an American epidemic of suicide.

Between 1999 and 2017 the age-adjusted suicide rate in the U.S. climbed 33 percent, from 10.5 to 14 deaths per 100,000 people, according to the Centers for Disease Control and Prevention. And the rise has been accelerating. The rate of suicide—the second leading cause of death in the U.S. among people ages 10 to 34 and the tenth overall—rose by an average of 1 percent a year between 1999 and 2006, after which it rose at double that pace. And although males in every age group are far more likely to take their own lives than girls and women are, females are slowly closing the gap.

Every year seems to bring a fresh helping of these dark statistics. A new CDC analysis looked at both suicide attempts and mortality. It reported that the sharpest rise in attempts—up a shocking 8 percent annually between 2006 and 2015—occurred among youngsters ages 10 to 19. (The study captured only the attempts that led to a hospital visit.) Nearly 80 percent of attempts were among people younger than 45, although there was also a rise in the 65-to-74 age group. As others have found, the incidence of attempts, as well as of fatalities, was shown to be rising faster in women and girls than in men and boys. Sadly, this “was not surprising to us,” says lead author Jing Wang, an epidemiologist at the CDC’s National Center for Injury Prevention and Control. The study also documented a rise in lethality—that is, a higher rate of attempts that resulted in death.

Measuring trends is a lot easier than explaining them. The suicide epidemic among adolescents and young adults, for example, “is consistent with the broader finding on rising rates of depression and depressed mood in young people,” says psychiatrist and epidemiologist Mark Olfson of Columbia University. On the other hand, he notes, “it’s a real puzzle that suicide rates are going up at a time when substance use is going down in this age group.” The two usually go hand in hand.

A possible factor is how much time young people spend with digital devices. A 2018 study that drew on data from more than half a million teenagers, led by psychologist Jean Twenge of San Diego State University, found that screen time correlates with depressive symptoms and suicide-related behaviors (considering it, making a plan, attempting it), especially for girls. “The rise in social media, the threat of cyberbullying, of being ostracized, can be a triggering event,” Olfson says, but in terms of causality, he notes, “it’s a difficult hypothesis to evaluate.” Wang mentions



other factors for which there is indirect evidence, such as parental use of opioids and exposure to a loved one’s suicide.

Among adults, suicide attempts track with the lack of a college degree, age between 21 and 34, very low income, mental illness, and a history of violence or past suicide attempts, a large study by Olfson and his colleagues found. Adults are much more likely than teenagers to actually kill themselves, in part because they have easier access to more lethal means such as guns and because they are more planful and less impulsive. Adults who take their own lives are predominantly male and white or Native American, often with a history of substance use, mental disorders, past attempts, loneliness and personal loss.

Mental health professionals worry that the social isolation, financial hardships and anxiety related to the coronavirus pandemic might worsen suicide trends. Past research in Europe and in the U.S. has shown that for every 1 percent rise in unemployment, there is a 0.8 to 1 percent jump in suicides. The pattern could be different in 2020 if people get back to work quickly or if the response is more akin to that in a time of war. “The rates go down in wartime, maybe because people feel more joined to a larger cause,” says Michael Hogan, who served as commissioner of mental health in New York, Connecticut and Ohio. Still, he’s concerned.

Hogan, who is also a founder of the Zero Suicide movement, argues that rather than waiting to address such massive issues as mental illness, unemployment and loneliness, it makes sense to focus on low-cost interventions that start closer to the critical period when thoughts of suicide take hold. One key idea is to ensure that medical personnel screen for such thoughts as routinely as they check blood pressure and to train them in next steps for vulnerable people. A number of interventions, including support from crisis hotlines, could save lives—if offered in time. ■



ECONOMICS

MEASURING WHAT MATTERS

Obsession with one financial figure, GDP, has worsened people's health, happiness and the environment, and economists want to replace it

By Joseph E. Stiglitz

Illustrations by Samantha Mash



Joseph E. Stiglitz is a University Professor at Columbia University and chief economist at the Roosevelt Institute. He received the Nobel prize in economics in 2001. Stiglitz chaired President Bill Clinton's Council of Economic Advisers from 1995 to 1997 and served as the chief economist and senior vice president of the World Bank from 1997 to 2000. He chaired the Sarkozy commission (2008–2009) and an expert group (2013–2019) at the OECD for devising measures for well-being and sustainability.



S

INCE WORLD WAR II, MOST COUNTRIES AROUND THE WORLD HAVE COME TO use gross domestic product, or GDP, as the core metric for prosperity. The GDP measures market output: the monetary value of all the goods and services produced in an economy during a given period, usually a year. Governments can fail if this number falls—and so, not surprisingly, governments strive to make it climb. But striving to grow GDP is not the same as ensuring the well-being of a society.

IN BRIEF

Gross domestic product (GDP)

is almost universally used to gauge how well a society is doing. In fact, it is a measure of market activity—no more.

The Great Recession of 2008–2009 highlighted the need for better ways to measure the well-being of an economy and society, as well as its sustainability—whether or not good times can last.

Over the past decade leading scholars have devised a broad set of measures to help steer societies toward the futures their citizens desire. Several countries are embedding these “dashboard” indicators into their decision-making processes.

In truth, “GDP measures everything,” as Senator Robert Kennedy famously said, “except that which makes life worthwhile.” The number does not measure health, education, equality of opportunity, the state of the environment or many other indicators of the quality of life. It does not even measure crucial aspects of the economy such as its sustainability: whether or not it is headed for a crash. What we measure matters, though, because it guides what we do. Americans got an inkling of this causal connection during the Vietnam War, with the military’s emphasis on “body counts”: the weekly tabulation of the number of enemy soldiers killed. Reliance on this morbid metric led U.S. forces to undertake operations that had no purpose except to raise the body count. Like a drunk looking for his keys under the lamppost (because that is where the light is), the emphasis on body counts kept us from understanding the bigger picture: the slaughter was inducing more Vietnamese people to join the Viet Cong than U.S. forces were killing.

Now a different body count—that from COVID-19—is proving to be a horribly good measure of societal performance. It has little correlation with GDP. The U.S. is the richest country in the world, with a GDP of more than \$20 trillion in 2019, a figure that suggested we had a highly efficient economic engine, a racing car that could outperform any other. But the U.S. recorded upward of 100,000 deaths by June, whereas Vietnam, with a GDP of \$262 billion (and a mere 4 percent of U.S. GDP per capita) had zero. In the race to save lives, this less prosperous country has beaten us handily.

In fact, the American economy is more like an ordinary car whose owner saved on gas by removing the spare tire, which was fine until he got a flat. And what I call “GDP thinking”—seeking to boost GDP in the mis-

placed expectation that that alone would enhance well-being—led us to this predicament. An economy that uses its resources more efficiently in the short term has higher GDP in that quarter or year. Seeking to maximize that macroeconomic measure translates, at a microeconomic level, to each business cutting costs to achieve the highest possible short-term profits. But such a myopic focus necessarily compromises the performance of the economy and society in the long term.

The U.S. health care sector, for example, took pride in using hospital beds efficiently: no bed was left unused. In consequence, when SARS-CoV-2 reached America there were only 2.8 hospital beds per 1,000 people—far fewer than in other advanced countries—and the system could not absorb the sudden surge in patients. Doing without paid sick leave in meat-packing plants increased profits in the short run, which also increased GDP. But workers could not afford to stay home when sick; instead they came to work and spread the infection. Similarly, China made protective masks cheaper than the U.S. could, so importing them increased economic efficiency and GDP. That meant, however, that when the pandemic hit and China needed far more masks than usual, hospital staff in the U.S. could not get enough. In sum, the relentless drive to maximize short-term GDP worsened health care, caused financial and physical insecurity, and reduced economic sustainability and resilience, leaving Americans more vulnerable to shocks than the citizens of other countries.

The shallowness of GDP thinking had already become evident in the 2000s. In preceding decades, European economists, seeing the success of the U.S. in increasing GDP, had encouraged their leaders to follow American-style economic policies. But as signs of dis-

stress in the U.S. banking system mounted in 2007, France's President Nicolas Sarkozy realized that any politician who single-mindedly sought to push up GDP to the neglect of other indicators of the quality of life risked losing the confidence of the public. In January 2008 he asked me to chair an international commission on the Measurement of Economic Performance and Social Progress. A panel of experts was to answer the question: How can nations improve their metrics? Measuring that which makes life worthwhile, Sarkozy reasoned, was an essential first step toward enhancing it.

Coincidentally, our initial report in 2009, provocatively entitled *Mismeasuring Our Lives: Why GDP Doesn't Add Up*, was published right after the global financial crisis had demonstrated the necessity of revisiting the core tenets of economic orthodoxy. It met with such positive resonance that the Organization for Economic Co-operation and Development (OECD)—a think tank that serves 37 advanced countries—decided to follow up with an expert group. After six years of consultation and deliberation, we reinforced and amplified our earlier conclusion: GDP should be dethroned. In its place, each nation should select a “dashboard”—a limited set of metrics that would help steer it toward the future its citizens desired. In addition to GDP itself, as a measure for market activity (and no more) the dashboard would include metrics for health, sustainability and any other values that the people of a nation aspired to, as well as for inequality, insecurity and other harms that they sought to diminish.

These documents have helped crystallize a global movement toward improved measures of social and economic health. The OECD has adopted the approach in its Better Life Initiative, which recommends 11 indicators—and provides citizens with a way to weigh these for their own country, relative to others, to generate an index that measures their performance on the things they care about. The World Bank and the International Monetary Fund (IMF), traditionally strong advocates of GDP thinking, are now also paying attention to environment, inequality and sustainability of the economy.

A few countries have even incorporated this approach into their policy-making frameworks. New Zealand, for instance, embedded “well-being” indicators in the country's budgetary process in 2019. As the country's finance minister, Grant Robertson, put it: “Success is about making New Zealand both a great place to make a living and a great place to make a life.” This emphasis on well-being may partly explain the nation's triumph over COVID-19, which appears to have been eliminated after roughly 1,500 confirmed cases and 20 deaths in a total population of nearly five million.

APPLES AND ARMAMENTS

NECESSITY IS THE MOTHER of invention. Just as the dashboard emerged from a dire need—the inadequacy of the GDP as an indicator of well-being, as revealed by the Great Recession of 2008—so did the GDP. During the Great Depression, U.S. officials could barely quantify

the problem. The government did not collect statistics on either inflation or unemployment, which would have helped them steer the economy. So the Department of Commerce charged economist Simon Kuznets of the National Bureau of Economic Research with creating a set of national statistics on income. Kuznets went on to construct the GDP in the 1940s as a simple metric that could be calculated from the exceedingly limited market data then available. An aggregate of (the dollar value of) the goods and services produced in the country, it was equivalent to the sum of everyone's income—wages, profits, rents and taxes. For this and other work, he received the Nobel Memorial Prize in Economic Sciences in 1971. (Economist Richard Stone, who created similar statistical systems for the U.K., received the prize in 1984.)

Kuznets repeatedly warned, however, that the GDP only measured market activity and should not be mistaken for a metric of social or even economic well-being. The figure included many goods and services that were harmful (including, he believed, armaments) or useless (financial speculation) and excluded many essential ones that were free (such as caregiving by homemakers). A core difficulty with constructing such an aggregate is that there is no natural unit for adding the value of even apples and oranges, let alone of such disparate things as armaments, financial speculation and caregiving. Thus, economists use their prices as a proxy for value—in the belief that, in a competitive market, prices reflect how much people value apples, oranges, armaments, speculation or caregiving relative to one another.

This profoundly problematic assumption—that price measures relative value—made the GDP quite easy to calculate. As the U.S. recovered from the Depression by ramping up the production and consumption of material goods (in particular, armaments during World War II), GDP grew rapidly. The World Bank and the IMF began to fund development programs in former colonies around the world, gauging their success almost exclusively in terms of GDP growth.

Over time, as economists focused on the intricacies of comparing GDP in different eras and across diverse countries and constructing complex economic models that predicted and explained changes in GDP, they lost sight of the metric's shaky foundations. Students seldom studied the assumptions that went into constructing the measure—and what these assumptions meant for the reliability of any inferences they made. Instead the objective of economic analysis became to explain the movements of this artificial entity. GDP became hegemonic across the globe: good economic policy was taken to be whatever increased GDP the most.

In 1980, following a period of seemingly poor economic performance—stagflation, marked by slow growth and rising prices—President Ronald Reagan assumed office on the promise of ramping up the economy. He deregulated the financial sector and cut taxes for the better-off, arguing that the benefits would “trickle down” to those less fortunate. Although GDP

(Mis)measuring Well-Being

Gross domestic product, or GDP, measures the total quantity of goods and services produced in an economy in a certain period, usually a year. Though commonly used to indicate how well an economy and society are doing, it is merely a measure of market activity—no more. Since the Great Recession of 2008, a global movement has emerged to replace the GDP with a “dashboard” of indicators that can better help steer countries toward a healthier and more sustainable future.

FAIR SHARE

The GDP per capita is obtained by dividing the GDP by the population of a country and can increase even if the quality of life of most people in a country worsens. A key indicator of the divergence between GDP and social well-being is inequality. In the U.S., for instance, the GDP has increased steadily since the 1960s, but so has inequality. The three richest men in the U.S. already own more wealth than the bottom half of the population combined, and the pandemic is aggravating the disparity.

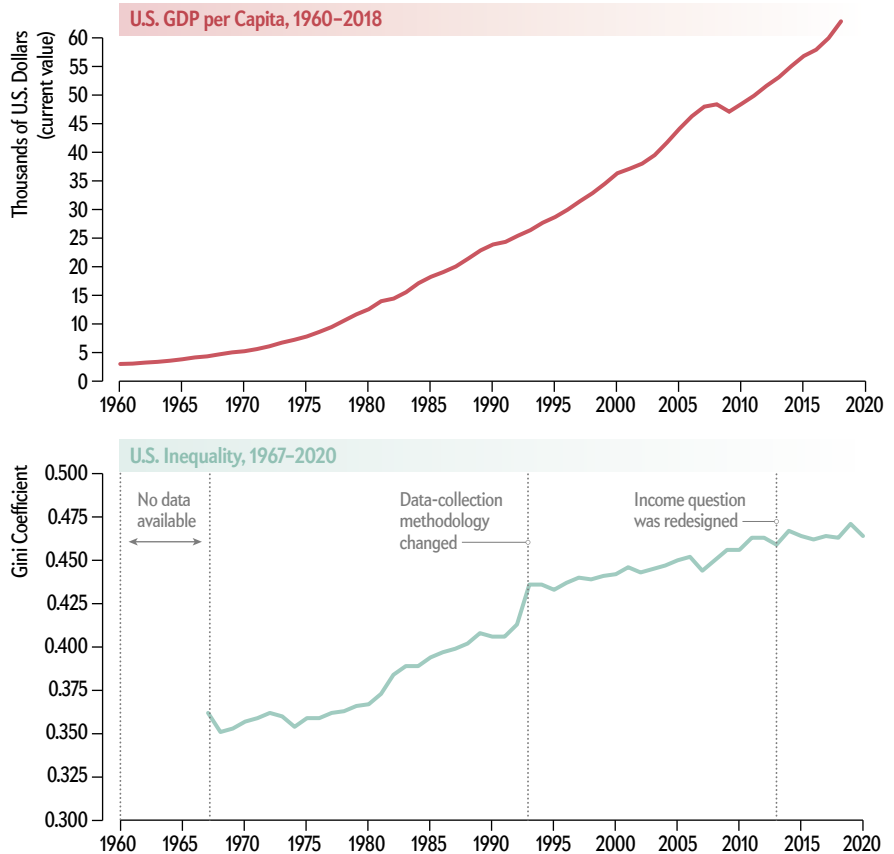

QUALITY OF LIFE

The Organization of Economic Co-operation and Development (OECD) lists 11 indicators for the quality of life. This chart compares the performances of two OECD members on these metrics. Although per capita income is far higher in the U.S., New Zealand scores better on the quality of environment and health, life satisfaction, and a sense of community and civic engagement.

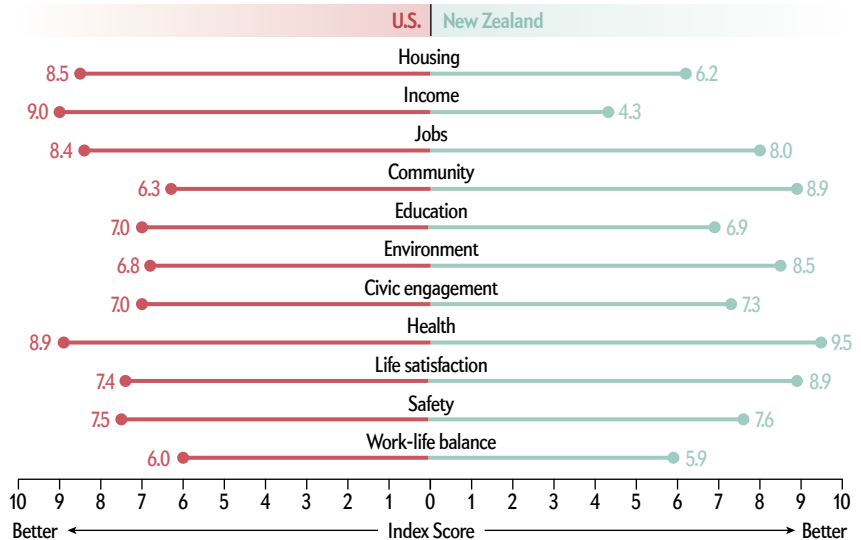

SOURCES: WORLD BANK (GDP data); U.S. CENSUS BUREAU (inequality data); ORGANIZATION FOR ECONOMIC CO-OPERATION AND DEVELOPMENT (Better Life Index data)

grew somewhat (albeit at a rate markedly lower than in the decades after World War II), inequality rose precipitously. Well aware that metrics matter, some members of the administration reportedly argued for stopping the collection of statistics on inequality. If Americans did not know how bad inequality was, presumably we would not worry about it.

The Reagan administration also unleashed unprecedented assaults on the environment, issuing leases for fossil-fuel extraction on millions of acres of public lands, for example. In 1995 I joined the Council of Economic Advisers for President Bill Clinton. Worrying that our metrics paid too little attention to resource depletion and environmental degradation, we worked with the Department of Commerce to develop a measure of “green” GDP, which would take such losses into account. When the congressional representatives from the coal states got wind of this, however, they threatened to cut off our funding unless we stopped our work, which we were obliged to.

The politicians knew that if Americans understood how bad coal was for our economy *correctly measured*, then they would seek the elimination of the hidden subsidies that the coal industry receives. And they might even seek to move more quickly to renewables. Although our efforts to broaden our metrics were stymied, the fact that these representatives were willing to spend so much political capital on stopping us convinced me that we were on to something really important. (And it also meant that when, a decade later, Sarkozy approached me about heading an international panel to examine better ways of measuring “economic performance and social progress,” I leaped at the chance.)

I left the Council of Economic Advisers in 1997, and in the ensuing years the deregulatory fervor of the Reagan era came to grip the Clinton administration. The financial sector of the U.S. economy was ballooning, driving up GDP. As it turned out, many of the profits that gave that sector such heft were, in a sense, phony. Bankers’ lending practices had generated a real-estate bubble that had artificially enhanced profits—and, with their pay being linked to profits, had increased their bonuses. In the ideal free-market economy, an increase in profits is supposed to reflect an increase in societal well-being, but the bankers’ takings put the lie to that notion. Much of their profits resulted from making others *worse* off, such as when they engaged in abusive credit-card practices or manipulated LIBOR (for London Interbank Offered Rate of interest for international banks lending to one another) to enhance their earnings.

But GDP figures took these inflated figures at face value, convincing policy makers that the best way to grow the economy was to remove any remaining regulations that constrained the finance sector. Long-standing prohibitions on usury—charging outrageous interest rates to take advantage of the unwary—were stripped away. In 2000 the so-called Commodity Modernization Act was passed. It was designed to ensure that derivatives (risky financial products that played a big role in

bringing down the financial system just eight years later) would never be regulated. In 2005 a bankruptcy law made it more difficult for those having trouble paying their bills to discharge their debts—making it almost impossible for those with student loans to do so.

By the early 2000s two fifths of corporate profits came from the financial sector. That fraction should have signaled that something was wrong: an efficient financial sector should entail low costs for engaging in financial transactions and therefore should be small. Ours was huge. Untethering the market had inflated profits, driving up GDP—and, as it turned out, instability.

OPIOIDS, HURRICANES

THE BUBBLE BURST in 2008. Banks had been issuing mortgages indiscriminately, on the assumption that real-estate prices would continue to rise. When the housing bubble broke, so did the economy, falling more than it had since the immediate aftermath of World War II. After the U.S. government rescued the banks (just one firm, AIG, received a government bailout of \$130 billion), GDP improved, persuading President Barack Obama and the Federal Reserve to announce that we were well on the way to recovery. But with 91 percent of the gains in income in 2009 to 2012 going to the top 1 percent, the majority of Americans experienced none.

As the country slowly emerged from the financial crisis, others commanded attention: the inequality crisis, the climate crisis and an opioid crisis. Even as GDP continued to rise, life expectancy and other broader measures of health worsened. Food companies were developing and marketing, with great ingenuity, addictive sugar-rich foods, augmenting GDP but precipitating an epidemic of childhood diabetes. Addictive opioids led to an epidemic of drug deaths, but the profits of Purdue Pharma and the other villains in that drama added to GDP. Indeed, the medical expenditures resulting from these health crises also boosted GDP. Americans were spending twice as much per person on health care than the French but had lower life expectancy. So, too, coal mining seemingly boosted the economy, and although it helped to drive climate change, worsening the impact of hurricanes such as Harvey, the efforts to rebuild again added to GDP. The GDP number provided an optimistic gloss to the worst of events.

These examples illustrate the disjuncture between GDP and societal well-being and the many ways that GDP fails to be a good measure of economic performance. The growth in GDP before 2008 was not sustainable, and it was not sustained. The increase in bank profits that seemed to fuel GDP in the years before the crisis were not only at the expense of the well-being of the many people whom the financial sector exploited but also at the expense of GDP in later years. The increase in inequality was by any measure hurting our society, but GDP was celebrating the banks’ successes. If there ever was an event that drove home the need for new ways of measuring economic performance and societal progress, the 2008 crisis was it.



THE DASHBOARD

THE COMMISSION, led by three economists (Amartya Sen of Harvard University, Jean-Paul Fitoussi of the Paris Institute of Political Studies and me), published its first report in 2009, just after the U.S. financial system imploded. We pointed out that measuring something as simple as the fraction of Americans who might have difficulty refinancing their mortgages would have illuminated the smoke and mirrors underpinning the heady economic growth preceding the crisis and possibly enabled policy makers to fend it off. More important, building and paying attention to a broad set of metrics for present-day well-being and its sustainability—whether good times are durable—would help buffer societies against future shocks.

We need to know whether, when GDP is going up, indebtedness is increasing or natural resources are being depleted; these may indicate that the economic growth is not sustainable. If pollution is rising along with GDP, growth is not environmentally sustainable. A good indicator of the true health of an economy is the health of its citizens, and if, as in the U.S., life expectancy has been going down—as it was even before the pandemic—that should be worrying, no matter what is happening to GDP. If median income (that of the families in the middle) is stagnating even as GDP rises, that means the fruits of economic growth are not being shared.

It would have been nice, of course, if we could have

come up with a single measure that would summarize how well a society or even an economy is doing—a GDP plus number, say. But as with the GDP itself, too much valuable information is lost when we form an aggregate. Say, you are driving your car. You want to know how fast you are going and glance at the speedometer. It reads 70 miles an hour. And you want to know how far you can go without refilling your tank, which turns out to be 200 miles. Both those numbers are valuable, conveying information that could affect your behavior. But now assume you form a simple aggregate by adding up the two numbers, with or without “weights.” What would a number like 270 tell you? Absolutely nothing. It would not tell you whether you are driving recklessly or how worried you should be about running out of fuel.

That was why we concluded that each nation needs a dashboard—a set of numbers that would convey essential diagnostics of its society and economy and help steer them. Policy makers and civil-society groups should pay attention not only to material wealth but also to health, education, leisure, environment, equality, governance, political voice, social connectedness, physical and economic security, and other indicators of the quality of life. Just as important, societies must ensure that these “goods” are not bought at the expense of the future. To that end, they should focus on maintaining and augmenting, to the extent possible, their stocks of natural, human, social and physical capital. We also laid out a

research agenda for exploring links between the different components of well-being and sustainability and developing good ways to measure them.

Concern about climate change and rising inequality had already been fueling a global demand for better measures, and our report crystallized that trend. In 2015 a contentious political process culminated in the United Nations establishing a set of 17 Sustainable Development Goals. Progress toward them is to be measured by 232 indicators, reflecting the manifold concerns of governments and civil societies from around the world. So many numbers are unhelpful, in our view: one can lose sight of the forest for the trees. Instead another group of experts, chaired by Fitoussi, Martine Durand (chief statistician of the OECD) and me, recommended that each country institute a robust democratic dialogue to discover what issues its citizens most care about.

Such a conversation would almost certainly show that most of us who live in highly developed economies care about our material well-being, our health, the environment around us and our relations with others. We want to do well today but also in the future. We care about how the fruits of our economy are shared: we do not want a society in which a few at the top grab everything for themselves and the rest live in poverty.

A good indicator of the true health of an economy is the health of its citizens. A decline in life expectancy, even for a part of the population, should be worrying, whatever is happening to GDP. And it is important to know if, even as GDP is going up, so, too, is pollution—whether it is emissions of greenhouse gases or particulates in the air. That means growth is not environmentally sustainable.

The choice of indicators may vary across time and among countries. Countries with high unemployment will want to track what is happening to that variable; those with high inequality will want to monitor that. Still, because people generally want to know how they are doing in comparison with others, we recommended that the advanced countries, at least, share some five to 10 common indicators.

GDP would be among them. So would a measure of inequality or some pointer toward how the typical individual or household is doing. Over the years economists have formulated a rash of indicators of inequality, each reflecting a different dimension of the phenomenon. It may well be that societies where inequality has become particularly problematic may need to have metrics reflecting the depth of the poverty at the bottom and the excesses of riches at the top. To me, knowing what is happening to median income is of particular importance; in the U.S., median income has barely changed for decades, even as GDP has grown.

Employment is often used as an indicator of macroeconomic performance—an economy with a high unemployment rate clearly is not using all of its resources well. But in societies where paid work is associated with dignity, employment is a value in its own right. Other elements of the dashboard would include indicators for

environmental degradation (say, air or water quality), economic sustainability (indebtedness), health (life expectancy) and insecurity.

Insecurity has both subjective and objective dimensions. We can survey how insecure people feel: how worried they are about adverse effects or how prepared they feel to cope with a shock. But we can also predict the likelihood that someone falls below the poverty line in any given year. And some elements of the dashboard are “intermediate” variables—things that we may (or may not) value in themselves but that provide an inkling of how a society will function in the future. One of these is trust. Societies in which citizens trust their governments and one another to “do the right thing” tend to perform better. In fact, societies in which people have higher levels of trust, such as Vietnam and New Zealand, have dealt far more effectively with the pandemic than the U.S., for instance, where trust levels have declined since the Reagan era.

Policy makers need to use such indicators much as physicians use their diagnostic tools. When some indicator is flashing yellow or red, it is time to look deeper. If inequality is high or increasing, it is important to know more: What aspects of inequality are getting worse?

STEERING THROUGH STORMS

SINCE WE BEGAN our work on well-being indicators some dozen years ago, I have been amazed at the resonance that it has achieved. A focus on many of the elements of the dashboard has permeated policy making everywhere. Every three years the OECD hosts an international conference of nongovernmental organizations, national statisticians, government officials and academics furthering the “well-being” agenda, the most recent being in Korea in November 2018, with thousands of participants.

Whenever the conference next convenes, the global crisis in human societies that a microscopic virus has precipitated will surely be on the agenda. The full dimensions of it could take years or decades to become clear. Recovering from this calamity and steering complex societies through the even more devastating crises that loom—catastrophic climate change and biodiversity collapse—will require, at the very least, an excellent navigational system. To paraphrase the OECD: We have been developing the tools to help us drive better. It is time to use them. 

MORE TO EXPLORE

Mismeasuring Our Lives: Why GDP Doesn't Add Up. Joseph E. Stiglitz, Amartya Sen and Jean-Paul Fitoussi. New Press, 2010.

Measuring What Counts: The Global Movement for Well-Being. Joseph E. Stiglitz, Jean-Paul Fitoussi and Martine Durand. New Press, 2019.

People, Power, and Profits: Progressive Capitalism for an Age of Discontent. Joseph E. Stiglitz. W. W. Norton, 2019.

FROM OUR ARCHIVES

A Rigged Economy. Joseph E. Stiglitz; November 2018.

[scientificamerican.com/magazine/sa](https://www.scientificamerican.com/magazine/sa)

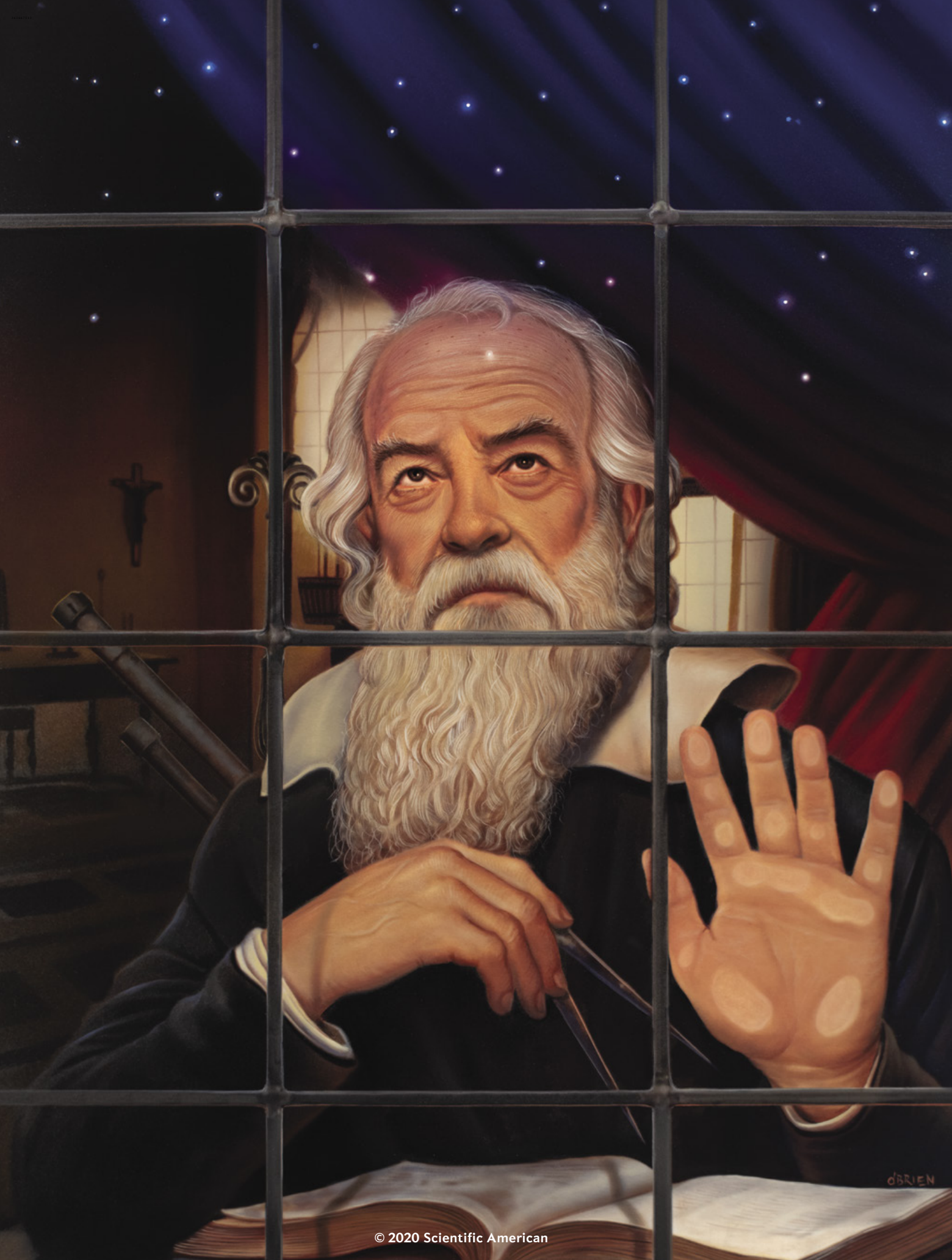

OBRIEN

GALILEO'S LESSONS

≡ *for* ≡

LIVING THROUGH A PLAGUE

An outbreak in Italy in the 1630s forced
him to find new ways of doing his research
and connecting with his family

By Hannah Marcus

Illustration by Tim O'Brien

Hannah Marcus is an assistant professor in the department of the history of science at Harvard University. Her research focuses on the scientific culture of early modern Europe between 1400 and 1700. Her book *Forbidden Knowledge: Medicine, Science, and Censorship in Early Modern Italy* will be published in September 2020.



T

HE NOVEL CORONAVIRUS HAS UPENDED OUR WORLD OVER THE PAST SEVERAL MONTHS, forcing people to learn how to work in entirely new ways. For scientists in particular, Isaac Newton has repeatedly been held up as a model of epidemic-induced productivity because he spent his 1666 “year of miracles” avoiding the plague in the English countryside and developing his ideas on gravity, optics and calculus. But isolation and quiet contemplation make up only one model of science during plague times and one that few of us can emulate. Galileo Galilei, the astronomer, physicist and mathematician who turned the telescope into a scientific instrument and laid the groundwork for a new physics of motion, presents us with an inspiring and more relatable model of scientific work in a time of crisis. In fact, several of the most public and turbulent years of Galileo’s life took place during the great plague outbreak of 1630–1633.

Galileo, who was born in 1564, had been a child in Florence during the previous major Italian outbreak of plague in 1575–1577, which ravaged northern Italy and killed some 50,000 people in Venice—one third of the total population. As a student of medicine at the University of Pisa, where Galileo began his studies, he certainly would have learned more about the notorious disease. Although he soon abandoned his father’s wish that he pursue medicine and turned instead to mathematics and astronomy, he nonetheless continued reading and talking about the plague.

By 1592 Galileo had achieved a prestigious position at the University of Padua, and in 1610 he published his *Starry Messenger*. The slim volume reported on the discoveries he made with his telescope: previously unseen stars burst from the frames of the pages, mountains soared from the surface of the moon, and new “Medicean stars” (actually, moons), initially named after his future patron, processed through their orbits around Jupiter. That same year his friend Ottavio Brenzoni sent him a copy of the treatise he had recently published on plague, which in retrospect serves as a reminder that Galileo’s discoveries in the heavens could never be entirely divorced from events on Earth.

Galileo’s correspondence contains regular references to the outbreak of plague in Tuscany that began in 1630. We read the defensive response of Galileo’s son, Vincenzo, after he fled to a small town outside Prato, leaving Galileo with his young son:

“Let me say first that when I decided to come here I did so out of desire to save my life, not for recreation or a change of air.”

We empathize with the dark humor of Galileo’s disciple Niccolò Aggiunti, professor of mathematics at Pisa, who moved back in with his father in Florence when the university closed and was lamenting this renewed parental oversight: “I want to live well ... but he wants me to die healthy.... As long as I don’t die of plague, he’s happy to have me die of hunger.” Looking back on our own lives of some months ago, we know just what Galileo’s dearest friend, mathematician Benedetto Castelli, meant when he reflected wearily in 1631 that it felt “like a thousand years” since Galileo had been in Rome with him.

Plague also became an obstacle and an opportunity for Galileo’s most famous and controversial publication. Galileo had been in Rome in the spring of 1630 to try to arrange for his *Dialogue concerning the Two Chief World Systems* to be published there. This required arranging for it to be printed through his scientific society, the Academy of the Lynx, and obtaining permission for publication through the Vatican’s censorship process. During that summer, however, plague appeared in Florence, and Galileo decided to print his dialogue locally, thereby greatly complicating normal censorship procedures. Parts of the *Dialogue* were checked by authorities in Rome, and other sections, including the final printing, were managed in Florence, with the reluc-

tant assent of the Roman censors. This disjointed, two-city, multiple-authority censorship process actually created space for Galileo to frame his arguments in favor of a moving Earth more forcefully than he might have otherwise been allowed.

In February 1632 Galileo's *Dialogue* was completed in Florence. Although mail between Florence and Rome ordinarily took only a few days, the plague outbreak had led cities to implement restrictions on travel and transportation of goods as a matter of public health. As a result, only two copies of the *Dialogue* had reached Rome by June, with six more copies arriving in July. With more copies came increased attention to its contents and argument. As the text reached the circles of Rome's Catholic elite, Pope Urban VIII and the Jesuits immediately expressed their outrage at the liberties Galileo had taken in times of plague. Within a week the book was banned. In September 1632 Galileo was summoned to Rome to testify before the Roman Inquisition. The epidemic was on the wane, and the trial of Galileo was about to begin.

Now the same delays that had impeded the mail and the publication and circulation of his book seemed to work in Galileo's favor, as he pleaded his own innocence and begged that the trial be moved to his home city of Florence. "And finally, in conclusion," he wrote at the end of a long letter to his friend the papal nephew, cardinal and inquisitor Francesco Barberini, "if neither my advanced age, nor my many physical conditions, neither the afflictions of my mind, nor the length of the journey in this present suspected time of tribulations [plague] are enough to stay the Tribunal ... then I will undertake this journey." The Roman Inquisition responded in no uncertain terms: Galileo was to travel to Rome, or he would be arrested and brought there in chains.

On January 20, 1633, Galileo began his journey, which lasted more than three weeks and included mandatory quarantine. Six months later his trial ended. Galileo admitted his errors, renounced his own work before the Roman Inquisition and began the trip home from Rome to Siena to his villa in Arcetri, outside Florence, where he would spend the remaining nine years of his life under house arrest.

Although most observers of Galileo's censure and trial were concerned about his ideas, his daughter Sister Maria Celeste, a cloistered nun in the order of the Poor Clares, attended, at a distance, to Galileo's physical state. From behind the walls of her convent, Maria Celeste prepared him foods and remedies to ward off the plague. Along with a letter in November 1630, Maria Celeste enclosed two electuaries—medicines mixed with honey—in an attempt to protect his health. "The one that has no written label is composed of dried figs, nuts, rue and salt" and was bound together with honey. She advised him to "take it every morning, before eating, in a dose about the size of a walnut, followed im-

mediately by drinking a little Greek or other good wine, and they say it provides a marvelous defense [against plague]."

The second medicine was to be taken in the same manner, but Maria Celeste warned that it had a bitter taste. She promised him, though, that she could improve the recipe if he wanted to continue taking either one. Galileo's year of plague and Inquisition trials is also a tale of intergenerational care at a distance, as Maria Celeste worked from within the walls of her convent to leverage medical and spiritual remedies to support and sustain her beloved father.

Amid her concern for her father's reputation, Maria Celeste and other members of Galileo's family sent regular letters during his return trip, updating him on plague cases in the surrounding region. Their missives contained epidemiological gossip, tallying the local numbers of the newly infected and relaying the fates of those who had recovered or died. Galileo's family tracked the progress of the plague outbreak as they tracked his trip back home to a life of imprisonment. As we confront our own separation from loved ones, we should remember the ways in which Galileo's devoted family supported him at a distance during this tumultuous period.

Galileo's plague years illuminate the realities of scientific engagement in a world full of challenges. The challenges of articulating novel scientific discoveries that conflict with political and religious doctrine. The challenges of continuing an international scientific program over the course of nearly a decade of isolation and imprisonment. And, of course, the challenges of living in a time devastated by epidemic.

As we wrestle with how to continue our own scientific work in the face of the coronavirus pandemic, I suggest that we hold up Galileo as our exemplary plague scientist. Bolstered by his relationships with his family and friends and strengthened by electuaries of dried fruit and honey, Galileo's life teaches us that pursuing science has never been straightforward during an epidemic and that it is nonetheless essential to persevere. **SA**



JOHN MILTON VISITING GALILEO in 1638 during the Roman Inquisition.

MORE TO EXPLORE

Dialogue concerning the Two Chief World Systems—Ptolemaic and Copernican.

Galileo Galilei. Translated by Stillman Drake. University of California Press, 1953.

The Galileo Affair: A Documentary History. Maurice A. Finocchiaro. University of California Press, 1989.

Galileo's Daughter: A Historical Memoir of Science, Faith, and Love. Dava Sobel. Bloomsbury USA, 2011.

Galileo. John L. Heilbron. Oxford University Press, 2012.

FROM OUR ARCHIVES

The Roots of Science Denial. Katharine Hayhoe and Jen Schwartz; October 2017.

scientificamerican.com/magazine/sa



ECOLOGY

ANIMALS

ANIMALS
APART

Lobsters, birds and
some primates routinely
use social distancing to ward
off disease, although people
are struggling with the strategy

By Dana M. Hawley and Julia C. Buck

Illustration by Nick Kilner

APART

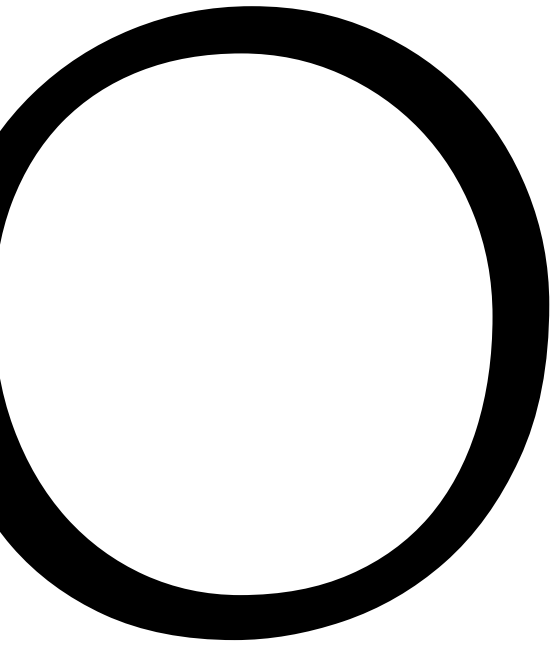

Dana M. Hawley is a professor at Virginia Tech who studies social behavior and disease among animals.



Julia C. Buck is an assistant professor at the University of North Carolina at Wilmington, where she runs a disease ecology laboratory.

IN A SHALLOW REEF IN THE FLORIDA KEYS, A YOUNG CARIBBEAN SPINY LOBSTER returns from a night of foraging for tasty mollusks and enters its narrow den. Lobsters usually share these rocky crevices, and tonight a new one has wandered in. Something about the newcomer is not right, though. Chemicals in its urine smell different. These substances are produced when a lobster is infected with a contagious virus called *Panulirus argus* virus 1, and the healthy returning lobster seems alarmed. As hard as it is to find a den like this one, protected from predators, the young animal backs out, into open waters and away from the deadly virus.

IN BRIEF

Despite how unnatural social distancing may feel to people, it is very much a part of the natural world, practiced by mammals, fishes, insects and birds. **Social animals stay apart**, changing behaviors such as grooming to stop the spread of diseases that could kill them. **Strategies vary** from shunning a sick animal to maintaining interactions with only the closest relatives.

The lobster's response to disease—seen in both field and laboratory experiments—is one we have become all too familiar with this year: social distancing. People's close interactions with family and friends have been cut off to reduce the spread of COVID-19. It has been extremely hard. And many have questioned the necessity. Yet despite how unnatural it may feel to us, social distancing is very much a part of the natural world. In addition to lobsters, animals as diverse as monkeys, fishes, insects and birds detect and distance themselves from sick members of their species.

This kind of behavior is common because it helps social animals survive. Although living in groups makes it easier for animals to capture prey, stay warm and avoid predators, it also leads to outbreaks of contagious diseases. (Just ask any human parent with a child in day care.) This heightened risk has favored the evolution of behaviors that help animals avoid infection. Animals that social distance during an outbreak are the ones most likely to stay alive. That, in turn, increases their chances to produce offspring that also practice social distancing when confronted with disease. These actions are what disease ecologists such as ourselves term "behavioral immunity." Wild animals do not have vaccines, but they can prevent disease by how they live and act.

Immunity through behavior does come with costs,

though. Social distancing from other members of your species, even temporarily, means missing out on the numerous benefits that favored social living in the first place. For this reason, researchers have learned that complete shunning is just one approach animals take. Some social species stay together when members are infected but change certain grooming interactions, for example, whereas others, such as ants, limit encounters between individuals that play particular roles in the colony, all to lower the risk of infection.

WORTH THE SACRIFICE

THE ABILITY OF SPINY LOBSTERS to detect and avoid infected group mates has been key to their persistence in the face of *Panulirus argus* virus 1, which kills more than half of the juvenile lobsters it infects. Young lobsters are easy pickings for the virus because the animals are so social, at times denning in groups of up to 20. Safe homes in sponges, corals or rocky crevices along the ocean floor—and a mass of snapping claws—help the group of creatures defend against hungry predators such as triggerfish. Nevertheless, in the early 2000s researcher Don Behringer of the University of Florida and his colleagues noticed that some young lobsters were denning solo, even though it left them vulnerable. Most of these lonely lobsters, the researchers found, were infected with the contagious virus. These lobsters

did not choose to den alone, the scientists suspected: they were being shunned. To confirm their hunch, the investigators placed several lobsters in aquarium tanks, allowing healthy crustaceans to choose an empty artificial den or one occupied by either a healthy or a diseased compatriot. In a 2006 article in *Nature*, the scientists reported that when disease was absent, healthy lobsters preferred being social and chose dens with a healthy lobster over empty ones. And lobsters strongly avoided the dens containing virus-infected lobsters, even though it meant they had to go it alone.

In a follow-up study published in 2013 in *Marine Ecology Progress Series*, Behringer and his colleague Joshua Anderson showed that healthy lobsters spot afflicted ones by using a sniff test. It turns out that infected lobsters have chemicals in their urine that serve as a danger signal to healthy group mates. When scientists used Crazy Glue to block the urine-releasing organs of infected lobsters, healthy animals no longer avoided the sick ones.

When lobsters detect an afflicted animal, they are willing to take considerable risks to stay disease-free. When Mark Butler of Old Dominion University and his colleagues tethered a sick lobster to the home den of healthy lobsters in the Florida Keys, they saw that healthy animals often abandoned safe havens for open waters, where they were at much higher risk of getting eaten. When Butler's team repeated the experiment with a tethered healthy lobster, there was no mass exodus. In their research, published in 2015 in *PLOS One*, the scientists used mathematical models to show that avoidance, while not without costs, prevents viral outbreaks that would otherwise devastate lobster populations.

PROTECT THE VALUABLE AND VULNERABLE

LOBSTERS ARE FAR FROM the only animals that have found the benefits of social distancing sometimes outweigh the costs. Some other creatures, in fact, have developed ways to boost the payoff by practicing social distancing strategically, in ways that protect the most valuable or vulnerable in their group. The most impressive examples occur in social insects, where different members of a colony have distinct roles that affect the colony's survival.

In work led by Nathalie Stroeymeyt of the University of Bristol in England and published in 2018 in the journal *Science*, researchers used tiny digital tags to track the movements of common garden ant colonies during an outbreak of a lethal fungus, *Metarhizium brunneum*. The spores of this fungus are passed from ant to ant through physical contact; it takes one to two days for the spores to penetrate the ant's body and cause sickness, which is often fatal. The delay between exposure and sickness allowed Stroeymeyt and her colleagues to see whether ants changed their social behaviors in the 24 hours after they first detected fungal spores in their colony but before fungus-exposed ants showed signs of sickness.



To measure how ants respond when disease first invades their colony, the researchers applied fungal spores directly to a subset of the forager ants that regularly leave the colony. The foragers are most likely to inadvertently encounter fungal spores while out searching for food, so this approach mimicked the natural way this fungus would be introduced. The behavioral responses of ants in 11 fungus-treated colonies were then compared with the same number of control colonies, where foragers were dabbed with a harmless sterile solution. Ants in fungus-exposed colonies started rapid and strategic social distancing after treatment. Within 24 hours those forager ants self-isolated by spending more time away from the colony compared with control-treated foragers.

Healthy ants in fungus-treated colonies also strongly reduced their social interactions, but the way they did so depended on their roles. Uninfected foragers, which interact frequently with other foragers that might carry disease, kept their distance from the colony when disease was present. This prevents them from inadvertently putting the reproductively valu-

STRATEGIC DISTANCE: Garden ants (1) stay away from their colony when exposed to a fungus. House finches (2) avoid other birds that appear ill.

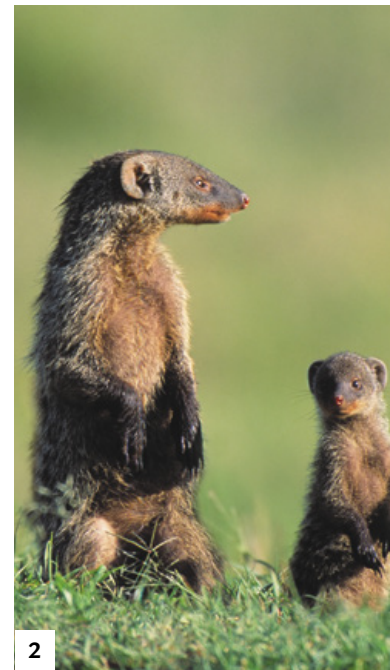

RELATIVE RISK:

Mandrills (1) groom close relatives even if they have parasites but avoid other contagious group mates. Banded mongooses (2), heavily dependent on group cooperation, groom both ill and healthy animals in their troop.

able colony members (the queen and “nurses” that care for the brood) at risk. The nurses also took action, moving the brood farther inside the nest and away from the foragers once the fungus was detected in the colony. The cues that the ants use to detect and rapidly respond to fungus exposure are still unknown, but this strategic social distancing was so effective that all queens and most nurses from the study colonies were still alive at the end of the experimental outbreaks.

Garden ants protect the most valuable members of their colony, but some birds use a different strategy, perhaps guided by the strength of their own immune responses and resistance to infection. Maxine Zylberberg and her colleagues placed house finches in three adjacent cages. Each central bird was flanked on one side by a healthy finch and on the other side by a finch that appeared sick. (It got an injection that made it act lethargic.) By observing the amount of time that the central bird spent on each side of its cage, the researchers showed that finches generally avoid birds that appear sick, but the degree of avoidance varied with the power of their own immune systems. Birds with higher bloodstream levels of antibodies and of one other protein that may signal broader immune activation showed less aversion. But birds with weaker levels of immunity avoided sick birds most strongly, the investigators reported in *Biology Letters* in 2013.

A similar pattern was detected in guppies affected by a contagious and debilitating worm called *Gyrodactylus turnbulli*. In work published in 2019 in *Biology Letters*, Jessica Stephenson of the University of Pittsburgh placed individual guppies that did not yet have worm infections in a central aquarium flanked by two

tanks. One was empty, and one contained a group of three guppies that represented potential contagion risk. Many guppies preferred the side of the tank near other guppies, as expected for a social species. But some male guppies strongly avoided the side of the tank near the other fish, and these distancing guppies were later shown to be highly susceptible to worm infections. It makes sense that evolution would favor a strong expression of distancing behavior in those most at risk.

THE TIES THAT BIND

STRATEGIC SOCIAL DISTANCING sometimes means maintaining certain social ties even when they raise disease risk. Mandrills, highly social primates with strikingly colorful faces, illustrate this approach. This species can be found in groups of tens to hundreds of individuals in the tropical rain forests of equatorial Africa. Groups typically have a mix of extended family members that frequently groom one another; grooming improves hygiene and cements social bonds. But they adjust their grooming behaviors in particular ways to avoid contagious group mates, Clémence Poirotte and his colleagues noted in a report published in 2017 in *Science Advances*. The scientists observed the daily grooming interactions of free-ranging mandrills in a park in Gabon and periodically collected fecal samples to learn which animals were heavily infected with intestinal parasites. Other mandrills actively avoided grooming those individuals. The mandrills could detect infection status based on smell alone: mandrills presented with two bamboo stalks rubbed in feces strongly avoided a stalk rubbed with droppings from another mandrill that had lots of parasites.

And yet mandrills sometimes forgo social distanc-

RAJF GELFAND/Getty Images (1); MIKE HILL/Getty Images (2)



ing in the face of contagion. In a follow-up study, also led by Poirotte, mandrills continued to groom certain close relatives that had high levels of parasites, even while distancing from other parasitized group members. In their 2020 publication in *Biology Letters*, the researchers said that maintaining strong and unconditional alliances with certain relatives can have numerous long-term benefits in nonhuman primates, just as in humans. In mandrills, females with the strongest social ties start breeding earlier and may have more offspring over their lifetimes. Such evolutionary gains associated with maintaining some social ties may be worth the risk of potential infection.

The social ties of some group-living animals may be so critical that avoidance will never be favored, even when group mates are obviously sick. For example, work led by Bonnie M. Fairbanks and published in 2015 in *Behavioral Ecology and Sociobiology* showed that banded mongooses do not avoid group members, even when they exhibit clear signs of disease. Banded mongooses are a highly social species native to sub-Saharan Africa and live in stable groups of up to 40 family members and nonrelatives. Group members engage in close physical interactions by resting on top of one another and taking turns grooming each other in a quid pro quo manner.

Kathleen A. Alexander of Virginia Tech, another author on the paper, first noted that many mongooses in her study area in Botswana get visibly sick with a novel form of tuberculosis that takes months to kill them. Fairbanks then spent months closely tracking six troops affected by this disease, observing all social interactions between troop members. Surprisingly, healthy mongooses continued to engage in close inter-

actions with visibly sick troop members. In fact, they groomed them to the same extent that they groomed their healthy troop mates, even though sick mongooses were far less likely to reciprocate. Distancing from sick group members may simply not be sustainable in species where close cooperation with other individuals for hunting and defense can make the difference between life and death.

FOLLOWING NATURE'S LEAD

LIKE OTHER ANIMALS, humans have a long evolutionary history with infectious diseases. Many of our own forms of behavioral immunity, such as feelings of disgust in dirty or crowded environments, are likely the results of this history. But modern humans, unlike other animals, have many advantages when plagues come to our doors. For instance, we can now communicate disease threats globally in an instant. This ability allows us to institute social distancing before disease appears in our local community—a tactic that has saved many lives. We have advanced digital communication platforms, from e-mail to group video chats, that allow us to keep our physical distance while maintaining some social connections. Other animals lose social ties with actual distance. But perhaps the biggest human advantage is the ability to develop sophisticated nonbehavioral tools, such as vaccines, that prevent disease without the need for costly behavioral changes. Vaccination allows us to maintain rich, interactive social lives despite contagious diseases such as polio and measles that would otherwise ravage us.

When it comes to stopping novel diseases like COVID-19, however, we are in much the same boat as other animals. Here, as in nature, tried-and-true behaviors such as social distancing are our best tools until vaccines or treatments can be developed. But just like other animals, we have to be strategic about it. Like mandrills and ants, we can maintain the most essential social interactions and distance farthest from those who are most vulnerable and who we could infect by accident. The success of spiny lobsters against a devastating virus in the Caribbean shows that short-term costs of social distancing, while severe, have long-term payoffs for survival. As unnatural as it may feel, we need only follow nature's lead. ■

MORE TO EXPLORE

Infection-Avoidance Behaviour in Humans and Other Animals. Valerie A. Curtis in *Trends in Immunology*, Vol. 35, No. 10, pages 457–464; October 2014.

No Evidence for Avoidance of Visibly Diseased Conspecifics in the Highly Social Banded Mongoose (*Mungos mungo*). Bonnie M. Fairbanks, Dana M. Hawley and Kathleen A. Alexander in *Behavioral Ecology and Sociobiology*, Vol. 69, No. 3, pages 371–381; March 2015.

Ecological and Evolutionary Consequences of Parasite Avoidance. J. C. Buck, S. B. Weinstein and H. S. Young in *Trends in Ecology and Evolution*, Vol. 33, No. 8, pages 619–632; August 2018.

FROM OUR ARCHIVES

The Social Lives of the Amboseli Baboons. Lydia Denworth; January 2019.

[scientificamerican.com/magazine/sa](https://www.scientificamerican.com/magazine/sa)

EVOLUTION

ASCENT OF THE OAKS

How they evolved to rule the forests
of the Northern Hemisphere

By Andrew L. Hipp, Paul S. Manos
and Jeannine Cavender-Bares

T



ANGEL OAK, a southern live oak located on Johns Island, S.C., is an estimated 400 to 500 years old.

Andrew L. Hipp is a senior scientist and herbarium director at the Morton Arboretum in Lisle, Ill. His research addresses the evolution, maintenance and implications of plant diversity, with a focus on the phylogenomics of oaks.

Paul S. Manos is a professor at Duke University. He studies the systematics and biogeography of the flowering plants, with a particular focus on the evolution of oaks, hickories and walnuts.

Jeannine Cavender-Bares is a professor at the University of Minnesota. She studies the origins, physiological function, and organization of plant biodiversity and their consequences, with an emphasis on oaks.



IF YOU WERE DROPPED INTO VIRTUALLY ANY REGION OF NORTH AMERICA 56 MILLION YEARS AGO, YOU probably would not recognize where you had landed. Back then, at the dawn of the Eocene epoch, the earth was warmer and wetter than it is today. A sea had just closed up in the middle of the Great Plains, and the Rocky Mountains had not yet attained their full height. The continent's plant and animal communities were dramatically different. In the Canadian High Arctic, which today harbors relatively few tundra plant species, year-round

temperatures above freezing nurtured a rich and diverse flora; Ellesmere Island in far northern Canada, across from the northwestern coast of Greenland, was home to alligators and giant tortoises. What is now the southeastern U.S. was dominated by tropical rain forest, complete with primates. The northeastern U.S., for its part, ranged from broad-leaved (as opposed to needle-leaved) evergreen forest to deciduous forests of ginkgo, viburnum, birch and elm, among other species. The deciduous broad-leaved forests that now cover 11 percent of North America north of Mexico were in their infancy. But that was about to change, with the spread and extraordinary diversification of what would eventually become some of the most ecologically and economically significant woody plants in the world: the acorn-bearing, wind-pollinated trees we call oaks.

Over the course of some 56 million years, oaks, which all belong to the genus *Quercus*, evolved from a single undifferentiated population into the roughly 435 species found today on five continents, ranging from Canada to Colombia and from Norway to Borneo. Oaks are keystone species, foundational to the functioning of the forests they form across the Northern Hemisphere. They foster diversity of organisms across the tree of life, from fungi to wasps, birds and mammals. They help clean the air, sequestering carbon dioxide and absorbing atmospheric pollutants. And they have shaped human culture, feeding us with their acorns and providing wood to build our homes, furniture and ships. Indeed, oaks have proved so valuable to people that we have immortalized them in legends and myths for centuries.

Oaks are especially prominent in the Americas. Approximately 60 percent of all *Quercus* species live here. This astounding variety,

along with the fact that the oaks in this region account for more forest tree biomass than any other woody plant genus in North America and Mexico, makes them the single most important group of trees in the continent's forests. To understand forests, then—their biodiversity, food webs and contributions to human well-being—one must understand how oaks came to rule them. For decades scientists could only speculate about much of the evolutionary history of oaks because of gaps in their fossil record and limitations of the biomolecular techniques used to infer evolutionary events from the DNA of living organisms. But recent advances in genome sequencing and analysis have allowed us and our colleagues to reconstruct a detailed picture of the origin, diversification and dispersal of oaks. It is a remarkable evolutionary success story, one that will have important implications for predicting how these essential trees will fare in the face of climate change—and for developing management plans to ensure their survival.

RED AND WHITE

THE DIFFERENCES BETWEEN MAJOR GROUPS of oaks are readily apparent to even a casual observer. In the Americas, oaks are dominated by two evolutionary lineages that you may already know. One of these, the red oak group, is composed of species with bristle-tipped leaves. In most red oak group species, pollen takes a full year from the time it lands on the female flower to fertilize the seed, so that acorns—the fruits of these trees—pollinated in one year only ripen in the next. Species in the other major lineage, the white oak group, have no bristles on their leaves, and the leaves generally contain more soil-enriching nutrients when they fall than those of red oaks do. Also, white oak acorns almost all ripen the same year

IN BRIEF

Oak trees are highly diverse and widespread, and they are keystone species in the forests they inhabit.

Advances in genomics have allowed researchers to reconstruct the evolutionary history of oaks.

The findings will have implications for managing oaks to ensure their survival as the planet warms.

they are pollinated, sometimes germinating before they even fall. Gray squirrels preferentially cache red oak acorns to eat at a later date because they are less likely than white oak acorns to go bad before the squirrels can get back to them.

White oaks are also able to efficiently plug the water-conducting, tubelike cells called vessels in their wood with tyloses, balloon-like structures that seal the vessels as a barrier against deadly fungal diseases such as oak wilt. Red oaks are slower and sloppy in their defense. Consequently, white oaks have long served as wood for ships and wine barrels because the plugged vessels of the white oak species hold water more effectively than those of the red oaks. Chewing insects recognize the differences between red and white oaks, and most are adapted to favor either one or the other of these two groups. Even mycorrhizal fungi, which connect plant roots to soil nutrients, appear to recognize the differences between the two types of oaks: many favor symbiotic relationships with species in one lineage over the other.

When we get to the species level, however, closely related oaks are often difficult to tell apart. The variation within species, the result of both plastic responses of the trees to their environment and genetic variation between individuals, often appears to be as great as the variation between species. And oaks hybridize commonly within their group, be it the white or red lineages or any of the six other major lineages of oaks worldwide. These two factors—high variation within species and ongoing hybridization between species—complicate classification.

Hybridization can also make it difficult to reconstruct the evolutionary history of oaks using traditional biomolecular techniques, which involve sequencing one or a few genes, because individual genes often trace different histories. Moreover, a single oak species may have hybridized with numerous different species, so that different genes record different aspects of this history across the geographical range of the species. The oak genome is thus a mosaic shaped by speciation and hybridization. The sequences of only one or a few genes cannot reveal the full history of speciation in oaks.

Two decades ago researchers had only the sequences of DNA from chloroplasts—the cell organelles that carry out photosynthesis—and a few nuclear genes to go on. It was enough to discern the overall branching structure of the oak tree of life, but we could not see the arrangement of its endmost branches. In 2008 the three of us realized that new molecular techniques we were already using to study hybridization and the limits of species in the red oak group might also enable us to infer oak evolutionary history. Since then, we, in collaboration with colleagues around the world, have employed an approach called restriction-site associated DNA sequencing to read short regions of DNA from across the genome. We analyze these data using statistical methods that reconstruct the order in which



RED OAKS have bristle-tipped leaves (1); the leaves of white oaks lack bristles (2).

species have branched from common ancestors and which ones have hybridized since that divergence. By marrying these analyses to fossil data, we can estimate the maximum ages of key events in oak evolutionary history. Despite the complex genetic history of oaks, we have been able to deduce much of the history of speciation in this group going back to the root of the oak tree of life.

SOUTHWARD BOUND

WE MAY NEVER KNOW precisely when or where the very first oaks arose, but roughly 56 million years ago a population of oaks growing near what is now Salzburg, Austria, left in the mud a bit of the massive amount of pollen they produced each spring. These pollen grains, which are shaped like a rugby ball with three grooves running lengthwise and with surface textures that vary by lineage, are the earliest unambiguous fossil evidence of oaks on record. Throughout the early Eocene, land bridges spanning the Atlantic and Pacific Oceans connected North America and Eurasia. Plants and animals freely crossed between the two continents. Oaks were most likely part of a vast forest that spread across the continents of North America, Europe and Asia. This makes it difficult to say with any confidence whether oaks originated in Eurasia and sent a branch off to the Americas, or vice versa. The better answer to where modern oaks arose may simply be “in the north.”

In any case, remarkably soon after they arose, oaks started to separate into two major branches: one limited to Europe, Asia and North Africa and the other largely limited to the Americas.

The separation between continents was imperfect at first. For example, the oldest fossil attributable to the ring-cupped oaks, based on the concentric rings formed by the woody scales on its acorn cap, was deposited in Oregon around 48 million years ago. Today this lineage is restricted to Southeast Asia. And red oaks, which today are an American group, have been reported from fossil sites in Europe dating to some 35 million years ago. But when global temperatures started their long descent about 52 million years ago, oaks were gradually pushed southward, away from the land bridges that have connected Eurasia and North America intermittently over the past 50 million years. As cooling drove northern oak populations extinct, the divisions between the two continents became very clean, with no species from the Eurasian clade showing up in the Americas and only two branches of the American clade showing up in Eurasia.

Before they could be pushed too far to the south, oaks were further subdivided into the eight major lineages we recognize in modern forests. Three of them are restricted to the Americas: the red, golden cup and southern live oaks. One lineage, that of the white oaks, originated and diversified in the Americas but sent an offshoot back to Eurasia. We know these major lineages arose early in

March of the Oaks

Over some 56 million years oaks have diversified into the 435 species alive today that together span five continents. Genome studies have allowed researchers to reconstruct the history of speciation in oaks. The findings help to explain how oaks came to be so diverse, particularly in the Americas, where some 60 percent of oak species reside.

Oak Classification

All living oak species are members of the genus *Quercus*, which comprises eight major lineages or sections, as they are termed. Two of these have dominated the Americas: the *Lobatae* section (also known as the red oaks) and the *Quercus* section (also known as the white oaks).

Diversity within Communities

Red oaks and white oaks often grow together in the same habitats. These two lineages colonized the same areas and independently developed solutions to the same ecological problems. In the Florida lowlands, white oak species differ across the sandhill, scrub and ravine habitats shaped by the karst terrain and by fire. Red oaks and members of a third lineage, *Virentes* (also known as the live oaks), do the same. Soil moisture availability and fire intensity structure these oak communities.

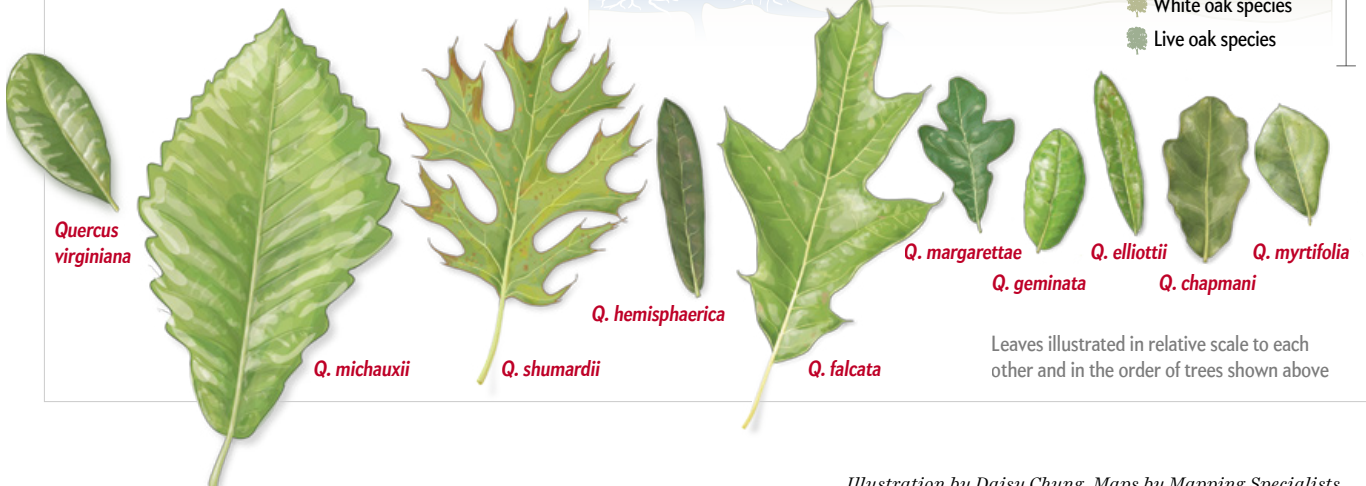
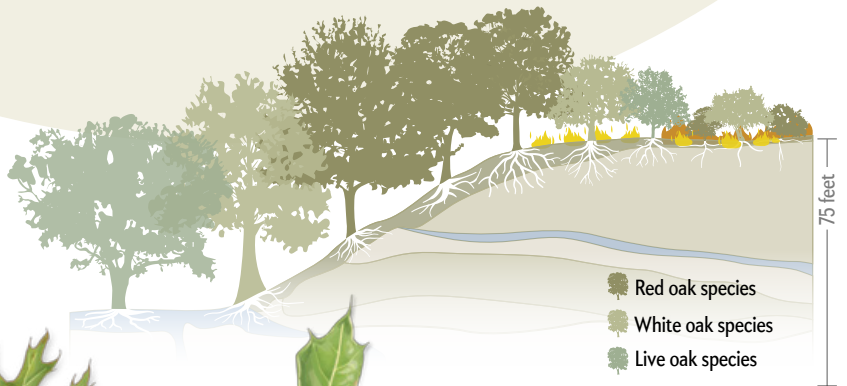
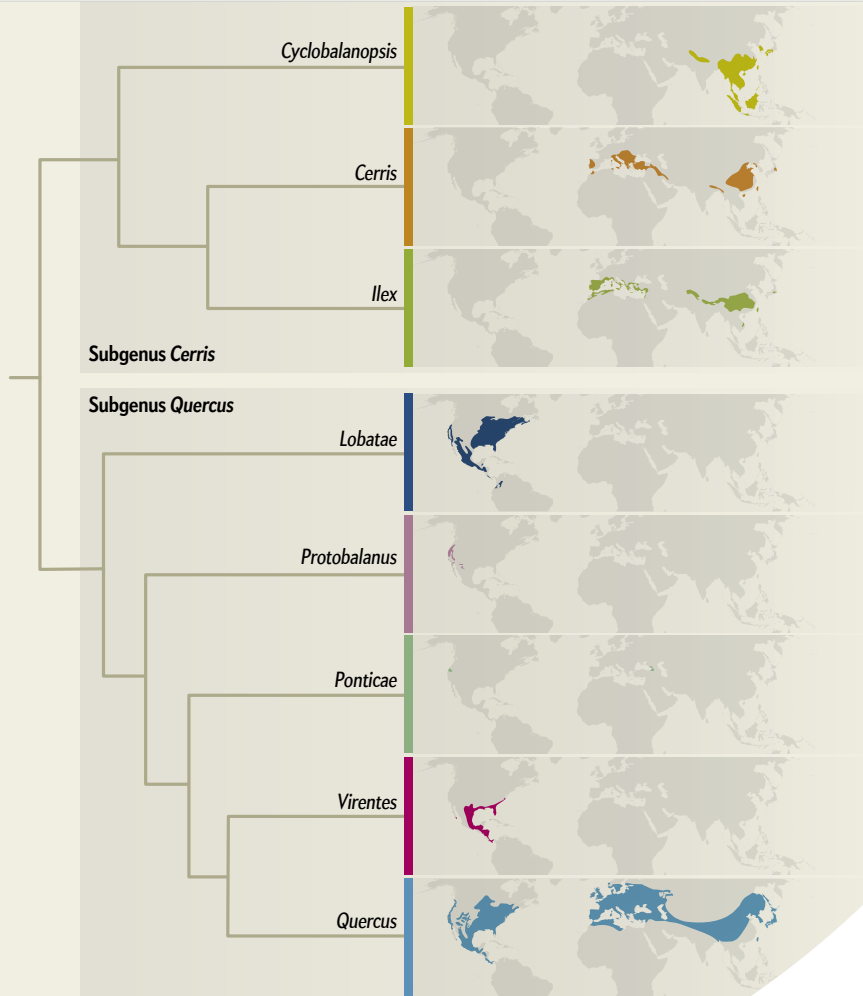

Leaves illustrated in relative scale to each other and in the order of trees shown above

Illustration by Daisy Chung, Maps by Mapping Specialists

Into the Americas

White oaks and red oaks arose and diversified simultaneously in the Americas. As these two groups moved south, each split into a lineage on the western side of the Rocky Mountains that gave rise to the oaks of California and the Pacific Northwest and into a lineage on the eastern side of the Rockies that gave rise to the oaks of eastern North America. On the eastern side, the red and white oaks each subdivided into northeastern, southeastern and Texan lineages. The red and white oaks then spread from eastern North America into Mexico, where they underwent another burst of diversification.

Red and white oak species

Ancestor of the Eurasian white oaks

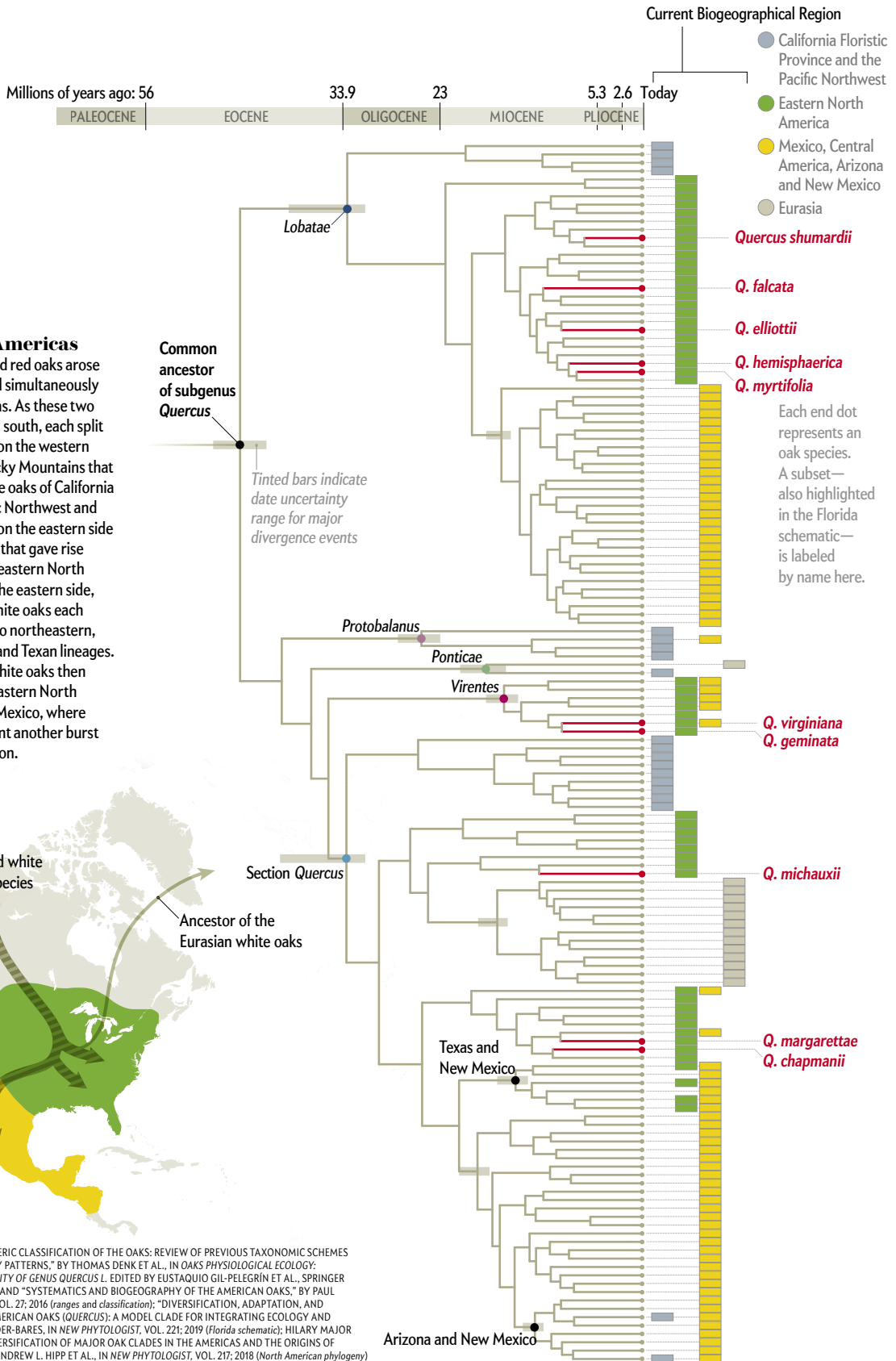

SOURCES: "AN UPDATED INFRAGENETIC CLASSIFICATION OF THE OAKS: REVIEW OF PREVIOUS TAXONOMIC SCHEMES AND SYNTHESIS OF EVOLUTIONARY PATTERNS," BY THOMAS DENK ET AL., IN *OAKS PHYSIOLOGICAL ECOLOGY: EXPLORING THE FUNCTIONAL DIVERSITY OF GENUS QUERCUS L.* EDITED BY EUSTAQUIO GIL-PELEGRIN ET AL., SPRINGER INTERNATIONAL PUBLISHING, 2017, AND "SYSTEMATICS AND BIOGEOGRAPHY OF THE AMERICAN OAKS," BY PAUL MANOS, IN *INTERNATIONAL OAKS*, VOL. 27: 2016 (ranges and classification); "DIVERSIFICATION, ADAPTATION, AND COMMUNITY ASSEMBLY OF THE AMERICAN OAKS (QUERCUS): A MODEL CLADE FOR INTEGRATING ECOLOGY AND EVOLUTION," BY JEANNINE CAVENDER-BARES, IN *NEW PHYTOLOGIST*, VOL. 221: 2019 (Florida schematic); HILARY MAJOR (leaves); "SYMPATRIC PARALLEL DIVERSIFICATION OF MAJOR OAK CLADES IN THE AMERICAS AND THE ORIGINS OF MEXICAN SPECIES DIVERSITY," BY ANDREW L. HIPPE ET AL., IN *NEW PHYTOLOGIST*, VOL. 217: 2018 (North American phylogeny)

oak evolution because one of the oldest American oak fossils is a 45-million-year-old white oak from Axel Heiberg Island in Nunavut, Canada, that can be distinguished from the red oaks and all other major lineages of oaks. But fossils from this initial phase of diversification are hard to assign to any one lineage, so we rely on molecular data to estimate when the other oaks separated into independent lineages. The integration of molecular data with selected fossils indicates that the world's eight lineages split early on. It is an important part of the story because it explains what happened next as the North American oaks underwent their own burst of diversification.



FOSSIL ACORN from Oregon dates to the Eocene epoch.

LANDS OF OPPORTUNITY

AS TEMPERATURES COOLED WORLDWIDE, the North American climate also became more seasonal. The Rocky Mountains were continuing to rise, and their rain shadow dried out the Great Plains. The tropical forests and broad-leaved evergreen forests that had flourished across North America were gradually restricted in range and driven to extinction by around 40 million years ago. Oak pollen and leaf impressions became more common in the North American fossil record 35 million years ago, by which time decreased temperatures and increased seasonality had converted North America north of Mexico from a mostly tropical to a mostly temperate continental landscape. As climate change extirpated tropical forests from North America, ecological opportunity arose for the oaks.

The red and white oaks moved south into this newly opened territory, each splitting into a lineage on the western side of the Rocky Mountains that gave rise to the modern-day oaks of California and the Pacific Northwest and into a lineage on the eastern side of the Rockies that gave rise to the oaks of eastern North America. Within the latter region, each of these major oak groups subdivided into a predominantly northeastern lineage, a predominantly southeastern lineage and a primarily Texan lineage. From eastern North America, perhaps by way of Texas, the red and white oaks then moved into Mexico between 10 million and 20 million years ago.

In all these areas, palms and broad-leaved evergreen trees had been pushed south or driven partially or wholly extinct by the cooling and increasingly fluctuating climate. The resulting abundance of open habitat enabled oaks to diversify. Increased ecological opportunity allowed oaks to undergo an adaptive radiation, in which nascent species rapidly fill spaces that other species are not occupying. In doing so, these young populations became more ecologically distinct from one another, thereby limiting the movement of genes between them. They became reproductively isolated, so that genes moved less between separated populations than among trees *within* populations. Subsequently, new genetic mutations and rearrangements could accumulate that distinguished the populations from one another. Through this process, they became new species.

This adaptive radiation played out most dramatically in Mexico and Central America, where about 40 percent of all the world's oaks reside. Recall that oaks were a largely cold-adapted lineage that spread across the continent as temperatures dropped and seasonality increased. As they migrated south into Mexico, oaks climbed

to higher elevations that more closely resembled the temperate biome in which they had evolved, and they encountered high topographic variation that readily separated them into reproductively isolated populations. Oaks also evolved more rapidly along the continuum from low water availability to high water availability as they moved into Mexico. Tacking up and down the mountains, different populations adapted to different levels of drought. This ecological differentia-

tion most likely worked hand in hand with increased physical separation to promote reproductive isolation between populations.

Thus, the reason for the high oak diversity in Mexico appears not to be warmer temperatures. And because Mexican oaks are relatively young, their high diversity has not accrued over comparatively long periods of evolutionary time. Rather adaptive radiation led to higher speciation rates in these evolutionarily young Mexican oaks as they moved into the mountains. This change suggests that if oaks had been suited to climb into the Rockies and flourish there—that is, if they could have survived the combination of short growing seasons and cold winters of the northern mountains—they might have developed high diversity in this region as well. Their evolutionary heritage simply did not equip them for these extremely harsh environments. Only a lone white oak species, the Gambel oak (*Quercus gambelii*), even comes close, and that species is limited to the southern Rockies.

The oaks were finally stopped in their march southward, perhaps by dramatic reduction in seasonality or strong competition from tropical forest species, only barely making it across the Isthmus of Panama into the north of South America. Yet this is not the whole story. The oaks' southward journey actually played out twice, simultaneously and in the same places. Because white and red oaks had already separated from each other by the time they started moving south, this diversification history happened in parallel in both the red and white oaks. Two distinct but very closely related lineages, not one, traced the biogeographical history we just described: moving south, splitting around the Rocky Mountains, heading into Mexico from an eastern North American ancestor. This history may explain part of the species richness and abundance of oaks in the Americas. They essentially double-dipped as they ventured south.

GOOD NEIGHBORS

ONE OF THE MOST EXCITING AREAS of our research has been the integration of a genome-level understanding of the oak tree of life with physiological studies of oak adaptation to climate and habitat and community studies of oak forest structure. As oaks spread south and diversified in different regions, the white and the red oaks encountered similar habitats and repeatedly solved the same ecological problems in novel ways. As a result, we often find red and white oaks growing together in the same habitats. For example, on poor rocky soils and bluffs in the eastern U.S., you can find the white oak *Quercus stellata*, also known as the post oak, growing next to the red oak *Quercus marilandica*, commonly called the blackjack oak. In the mountains of southern Arizona, the iconic white oak *Quercus arizonica* often grows beside the red oak *Quercus emoryi*.

THOMAS J. BONIES

This pattern of oak co-occurrence is found in wooded plant communities across much of the country, and it has another intriguing feature. Whereas distantly related oaks tend to grow together, closely related oaks within lineages tend not to be found together. Along an elevational gradient in the Chiricahua Mountains of southern Arizona, for example, white oak species pass the baton as you walk upslope, transitioning broadly from one to the next as you hike uphill, and red oak species do as well. In the lowlands of Florida, white oak species separate across the sandhill, scrub and ravine habitats shaped by karst topography and fire. Red oaks do the same.

What shapes this pattern of oak co-occurrence? Ecological differentiation within the red and white oaks is influenced in part by the fact that no single species is able to master every habitat. Instead species tend to specialize on a limited part of the available ecological space. In oaks, physiological trade-offs within each lineage subdivide habitat and climatic space so that close relatives are less likely to co-occur. In the Chiricahua Mountains, for instance, drought adaptation separates close relatives along the elevation gradient. Species living near the bottom of the mountain are particularly good at avoiding drought, dropping their leaves during dry seasons. Species living at higher elevation, where there is more overall moisture, focus on surviving daily fluctuations in water availability by allowing leaf water content to drop lower before they suffer damage.

In contrast, in Florida, which is comparatively flat, soil moisture availability and fire intensity structure oak communities. Closely related species in these communities show trade-offs between growth rate and drought tolerance along moisture gradients and between bark thickness and the ability to reproduce via underground stems along gradients of fire intensity. In both regions, and indeed across the country, parallel trade-offs are found in both red and white oaks, and trees with convergent traits from the two lineages tend to grow together.

Members of different lineages may co-exist well with one another in each habitat because they differ in their susceptibility to disease: proximity to a more distantly related neighbor may be less likely to result in an epidemic because red and white oaks tend not to spread the same diseases. There is even evidence that oaks help one another get established and persist by creating a soil environment that benefits the mycorrhizal fungi they need to acquire nutrients. Then, once a forest has become established, oaks become dominant and prevent other kinds of trees from setting up shop. Our work makes clear that the evolutionary origins of oaks shape the complex ecological interactions that help to explain why the trees are so abundant and diverse in North America. The tree of life casts its shadow across the structure of our oak forests.

CREATIVE HYBRIDIZATION

NOW THAT WE CAN DELINEATE the branching history of the oak tree of life in some detail, the trees' propensity to hybridize has become all the more interesting. People often think of hybridization as a destructive force, eroding genetic differences between species. Yet oaks form what is called a syngameon, in which ecologically and physically distinctive species persist in spite of ongoing gene flow. It has long been hypothesized that genes migrating between species of the syngameon might help oaks adapt to novel environments. Could, for example, genes that contribute to drought adaptation in the post oak migrate into the bur oak (*Quercus macrocarpa*) in the southern regions, where they co-occur, and help the bur oak adapt to the drying conditions it is expected to encounter under global warm-

ing? We know already that there is localized gene flow between oak species and that species differ in what genes they exchange depending on where on the landscape they are, what species they co-occur with, and the climate and habitat in which the trees are growing. We also know that after genes move from one species into the other, they can move beyond the range of the species in which they arose, apparently propelled by environmental selection. These examples suggest that adaptive gene flow may play an important role in oak evolution. We are on the cusp of the integrative genomic and ecological studies needed to understand this process in depth.

We would still like to know what genes and attributes—flowering time, habitat preference, geographical distance—drive speciation in oaks and whether ecological differences evolve while populations are growing together or only when they are separated. We are close to understanding what genes shape differentiation. Recent work in European oaks shows that genes influencing both their ability to cross-pollinate and their ecological preferences (for instance, tolerance of drought, cold and disease) are involved in species differentiation. Yet these findings only tell us that ecological differences evolve in species, not that they drive species differences. Statistical analyses that simulate alternative speciation histories suggest that in a group of four widespread European white oaks that hybridize today, the genomic differences between the species arose when the species were born in different geographical areas, with opportunities for gene flow arising only after the fully formed species migrated back into contact with each other. Still, the high degree of species co-occurrence in the American oaks raises the question of whether hybridization contributed to their diversity.

A firm grasp of when, where and how oaks came to be so diverse is crucial to understanding how oaks will resist and adapt to rapidly changing environments. Oaks migrated rapidly as continental glaciers receded starting around 20,000 years ago, and hybridization between species appears to have been key to their rapid response. The insights we can gain from elucidating the adaptive benefits of gene flow are critical to predicting how resilient oaks may be as climate change exposes them to fungal and insect diseases with which they did not evolve. As insects that transport pathogenic fungi increase their ranges and change their patterns of reproduction with earlier springs, oaks may have trouble holding their ground unless they can evolve quickly enough to resist diseases they have never before encountered. Our challenge for the coming decade as plant biodiversity scientists will be to figure out how differentiation between species and movement of genes between those species will influence the trajectory of oak evolution and population persistence. If we understand these processes well enough, we stand a chance of using that knowledge to predict what our forests will look like a century or more from now. Perhaps it can guide our plans to manage longer-term survival of the vital oaks. ■

MORE TO EXPLORE

Leaf-Level Trade-offs between Drought Avoidance and Desiccation Recovery Drive Elevation Stratification in Arid Oaks. Beth Fallon and Jeannine Cavender-Bares in *Ecosphere*, Vol. 9, No. 3; March 2018.

Oaks: An Evolutionary Success Story. Antoine Kremer and Andrew L. Hipp in *New Phytologist*, Vol. 226, No. 4, pages 987-1011; May 2020.

FROM OUR ARCHIVES

Sacred Groves. Madhav Gadgil; December 2018.

scientificamerican.com/magazine/sa

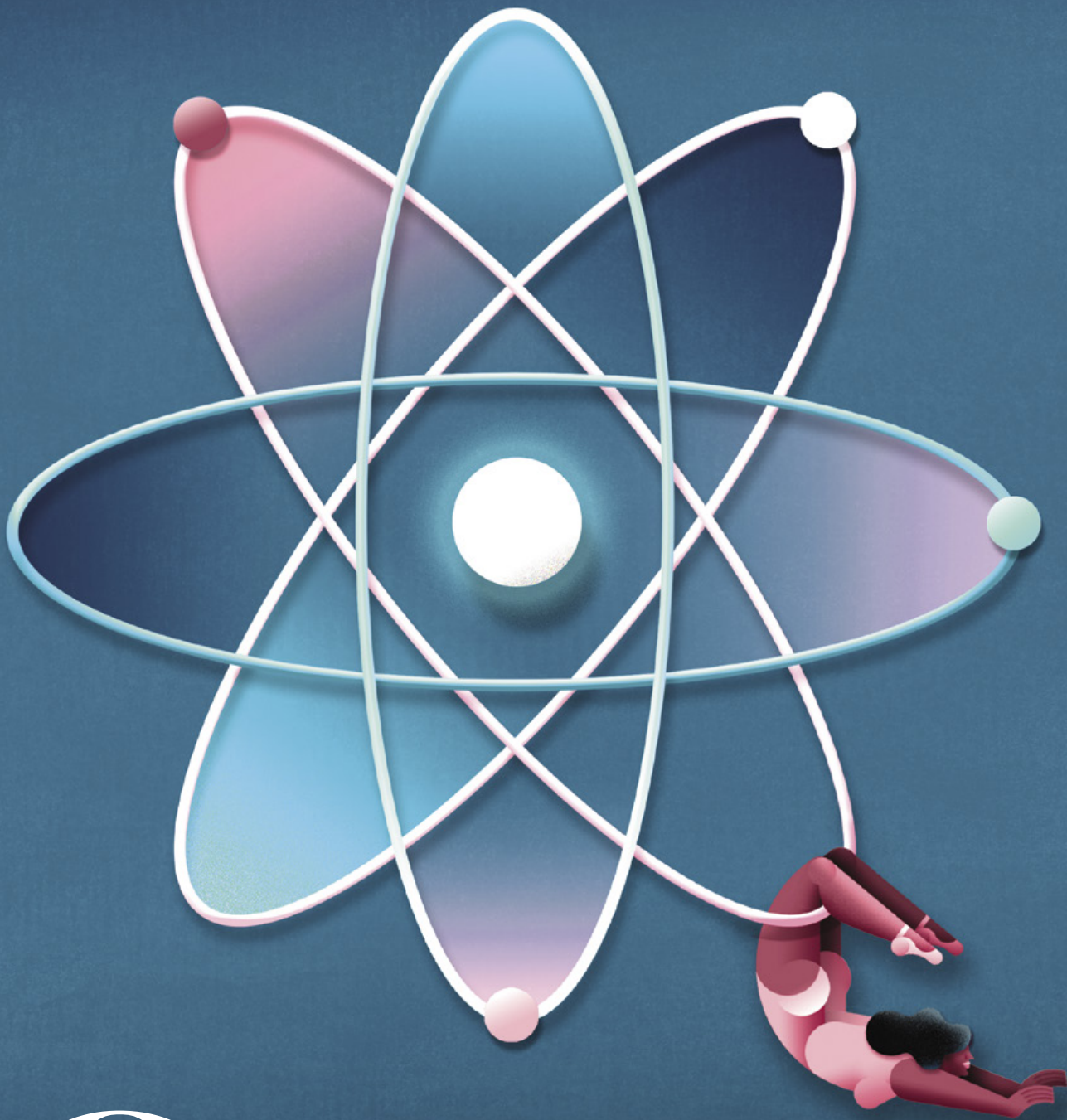

MATHEMATICAL PHYSICS

Quantu

The quest to solve one of the greatest open questions in physics:
How can a quantum phenomenon become macroscopic?

By Spyridon Michalakis

Illustration by María Corte

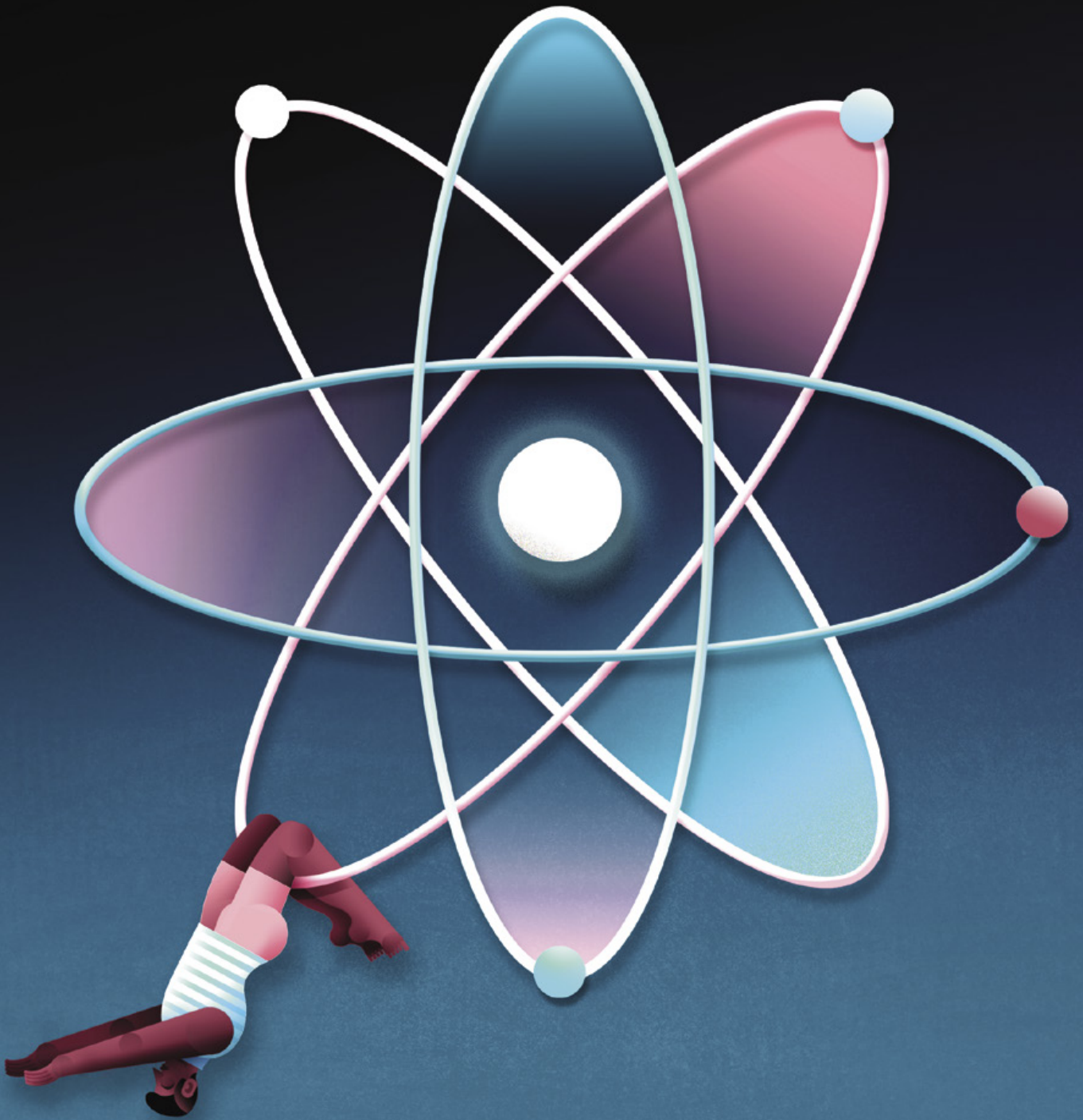

m Leap

Spyridon Michalakis is a mathematical physicist and manager of outreach for the Institute for Quantum Information and Matter at the California Institute of Technology.



I am sitting alone at the head of a large conference table when an oddly familiar voice greets me: “Hey, you must be Spiros!” I turn around to find Paul Rudd, the Hollywood actor, wearing his famed disarming smile. He is in sweats, on his way back from some type of superhero training.

A few minutes later he and a bunch of other film people are sitting around me. Rudd cuts straight to the chase: “So what kinds of cool things happen when you shrink?” I have been flown in to consult on the physics of Marvel Studios’ superhero flick *Ant-Man*, and now I must deliver. Yet all I really know about shrinking to ant size comes from watching *Honey, I Shrunk the Kids!* as a nine-year-old. For a moment, I consider telling him that he’s got the wrong guy, but there is no way I am going to let this opportunity slip between my fingers. I may not know much about ants, but I know a thing or two about quantum physics. “The concepts of time and space lose their usual meaning when you shrink to the quantum scale,” I reply with confidence. Reading the room, I can tell that this is the last thing they expected to hear. But they are hooked. The floor is mine for the next two hours, as I delve deeper and deeper into the rules and weirdness of quantum mechanics.

A day later one of the producers e-mails me: “Hey, what should we call the place you enter when you shrink to microscopic size?” I type back: “How about the Quantum Realm?” Five years later, in 2019, Marvel’s Avengers enter the Quantum Realm and travel back in time to save the universe. All of a sudden, being an expert in quantum physics seems pretty cool.

I was not always into physics or comic-book heroes. In college, I majored in mathematics and computer science, spending my summers trying to predict how one-dimensional DNA sequences folded into three-dimensional proteins. It was not until graduate school that I took my first physics class beyond the basic college requirements. My Ph.D. adviser at the University of California, Davis, had decided to enroll me in graduate-level quantum mechanics, and I had no choice but to go along with it. When on the first day of class we were handed a one-page undergraduate-

level assessment test, I returned mine with my name and a smiley face next to it. Still, I persisted, graduating in June 2008 with a doctorate in applied mathematics and an emphasis on mathematical physics and quantum information theory. Three months later I would pack my things and move to Los Alamos, N.M., the birthplace of the atomic bomb, to take a postdoctoral position at Los Alamos National Laboratory. I did not know it at the time, but during the next year I would delve deep within the quantum realm. This is the story of what I discovered there and how I made it back to tell Marvel the story.

SOMETHING INTERESTING

IT ALL BEGAN WITH A SIMPLE QUESTION.

My adviser at Los Alamos, Matthew Hastings, a rising star and one of the sharpest minds in physics, was sitting across from me at a sushi restaurant when he popped the fateful question: “For your postdoc here at the lab, do you want to start with a warm-up, or do you want to work on something interesting?” Without asking for further clarification, I answered, “I want to work on something interesting.” He seemed pleased with my answer. Later that day he sent me a link to a list of [13 unsolved problems in physics](#) maintained by Michael Aizenman, a professor at Princeton University and a towering figure in mathematical physics. I was to work on the second problem on that list, a question posed by mathematical physicists Joseph Avron and Ruedi Seiler: “Why is the Hall conductance quantized?”

You may wonder what the Hall conductance is or what it means for it to be quantized. I had the same questions back then. No problem on the list besides the third—cryptically titled “Exponents and Dimensions”—had “SOLVED!” next to it. Clicking

IN BRIEF

The quantum Hall effect is a macroscopic phenomenon involving electric current across a conducting surface that exhibits quantization—traditionally

reserved for the microscopic quantum realm. **Explaining why** this effect is quantized had been named a major unsolved problem in physics.

Recently mathematical physicists answered the question in a proof relying on topology—the study of the properties of shapes.

through, I saw that it was actually only partially solved. Yet one of those partial breakthroughs had led to a Fields Medal, one of the highest honors in mathematics, in 2006, and the other would earn one four years later. In this company, it was clear the problem I was tasked with solving was no ordinary quandary. I considered carefully if I could solve such a question within a year. The reason for the time limit is that a postdoc in math or physics usually lasts two years. At the end of your first year, if you have done great research, you may apply to top universities for a tenure-track professorship. If your research is good but not great, you may apply for a second postdoc or look for a less competitive tenure-track position. If you have nothing to show after your first year, there is always Wall Street.

Still, the idea of backing out now, without even trying to attack the problem, was difficult to swallow. For a person growing up in Spata, a small town outside of Athens, Greece, big dreams were unusual. My dad grew up in the same house I did. He played soccer and got into fights. When he eventually dropped out of high school, his dad offered him a position at the local grocery store. My father refused. Despite being a dropout, he had ambition. He interned at the local real-estate agency and learned the ropes of buying and selling land. Later, he went back to school to get his GED at my mother's insistence. Down the line, when my older brother, Nikos, brought home his first-grade report card, my father cried with happiness when he realized that his son was a good student. Nikos and I would go on to compete at the International Mathematical Olympiad, an honor afforded to six high school students from each country every year. Then, one after the other, Nikos, I and my younger brother, Marios, traded high school in Athens for college at the Massachusetts Institute of Technology in Cambridge—a rare accomplishment for any family, let alone one of modest means, and a testament to my parents. I thought that if they could perform miracles, maybe I could, too. So, in the fall of 2008, I began working on problem number two, aiming, as the list put it, to “formulate the theory of the integer quantum Hall effect, which explains the quantization of the Hall conductance, so that it applies also for interacting electrons in the thermodynamic limit.”

The integer quantum Hall effect has a long history. The original Hall effect was discovered in 1879 by Edwin H. Hall, a student at Johns Hopkins University. Young Hall had decided to challenge a claim made by the father of electromagnetism, James Clerk Maxwell. In his 1873 *Treatise on Electricity and Magnetism*, Maxwell confidently declared that, in the presence of a magnetic field, a conducting material with current flowing through it will bend because of the magnetic force on the material, not on the current. Maxwell concluded that “when a constant magnetic force is made to act on the system ... the distribution of the current will be found to be the same as if no magnetic force were in action.” To test the idea, Hall ran current across a thin leaf of gold placed in a magnetic field perpendicular to its surface and noticed that his galvanometer (an instrument used to detect small currents) registered a current, which implied a voltage (electric potential) in a direction *perpendicular* to that of the current's original path. He concluded that the magnetic field was pushing the electrons in the current toward one edge of the conductor, permanently changing their distribution on the surface of the material. Maxwell was wrong. This unexpected charge buildup along the conductor's edges became known as the Hall voltage.

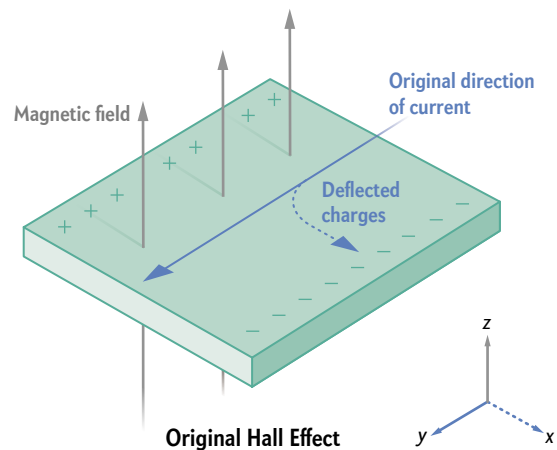

The *quantum* Hall effect was first observed nearly a century later, on February 5, 1980, in Grenoble, France, by German experimental physicist Klaus von Klitzing. His aim was to study the Hall effect more carefully under ultralow temperatures and high magnetic fields. He was looking for small deviations from the expected effect in certain two-dimensional semiconductors, the materials underlying all modern transistors. In particular, he was trying to measure the Hall resistance, a quantity proportional to the Hall voltage. What he observed was astonishing: the Hall resistance was quantized! Let me explain. As the strength of the magnetic field increased, the resistance between the edges of the material would stay exactly the same, until the field got high enough. Then, the resistance would jump to a new value instead of climbing up steadily the way Hall had originally observed—and all known physics at the time predicted. Even more surprisingly, the values of the Hall *conductance*, the inverse of the Hall resistance, were precise integer multiples of a quantity intimately related to the fine-structure constant, a fundamental constant of nature that describes the strength of the electromagnetic interaction between elementary charged particles. The integer quantum Hall effect was born.

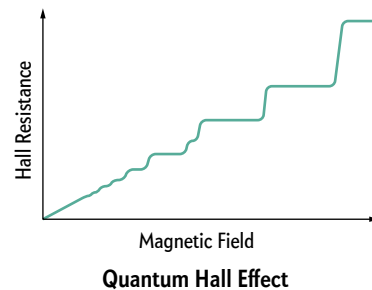

Von Klitzing's discovery was remarkable, not least of all because the fine-structure constant was supposed to describe aspects of the quantum realm that were too fine-grained for any macroscopic phenomenon, such as the Hall conductance, to be able to probe, let alone define with incredible precision. Yet not only did the Hall conductance capture an essential aspect of the microscopic world of quantum physics, it did so with impossible ease. The integer plateaus of the Hall resistance appeared irrespective of variations in the size, the purity or even the particular type of semiconducting material used in the experiment. It was as if a symphony of a trillion trillion electrons maintained their collective quantum tune across vast atomic distances without the

need for a master conductor and, even more astonishingly, were impervious to the principles of physics that, for billions of years, had guarded the quantum realm from macroscopic interlopers.

A door to the quantum realm was opened that day—a macroscopic door that many thought did not exist. In 1985, five years after the discovery, von Klitzing was awarded the Nobel Prize in Physics. His finding would lead to further breakthroughs, with three more Nobel Prizes awarded to two experimentalists (Horst Störmer and Daniel Tsui) and a theorist (Robert Laughlin) in 1998, for discovering that electrons acting together in strong magnetic fields can form new types of “particles,” with charges that are mere fractions of electron charges, a phenomenon now known as the fractional quantum Hall effect.

LAUGHLIN’S QUANTUM PUMP

LAUGHLIN WAS ONE OF THE FIRST PHYSICISTS to attempt an explanation of the quantum Hall effect. In 1981 he came up with a brilliant thought experiment—an idealized simulation of the original experiment that provided a mathematical metaphor to understand it. Laughlin imagined electrons traveling along a conducting loop with a flat edge, like a wedding band. A magnetic field ran perpendicular to the surface of the band, but Laughlin added a fictitious magnetic field line—called a magnetic flux—threading through the middle of the loop like a finger through the ring. Increasing the fictional flux induced a current running around the loop, thus introducing the longitudinal current present in the classical Hall effect. The process, named Laughlin’s quantum pump, would complete one cycle every time the fictional magnetic flux increased by one “flux quantum”—an amount defined as h/e , where h is Planck’s constant and e is the electron’s charge.

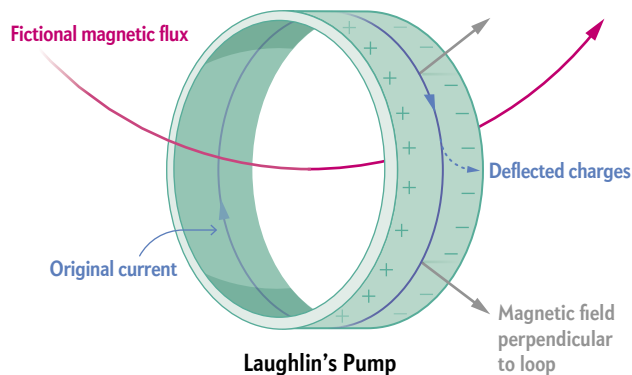

After each cycle, the quantum system would return to its original state as the result of a phenomenon known as gauge invariance. Laughlin argued that this reset implied that the Hall conductance was quantized in whole numbers equal to the number of electrons moved by the quantum pump. Great! Alas, there was an issue. The Hall conductance was experimentally measured (and averaged) over many cycles of the pump. Because Laughlin assumed (correctly) that the system was described by quantum mechanics, there was no guarantee that each cycle would transfer the same number of electrons. As Avron and Seiler would write later with their collaborator Daniel Osadchy: “Only in classical mechanics does an exact reproduction of a prior state guarantee reproduction of the prior measured result. In quantum mechanics, reproducing the state of the system does not necessarily reproduce the measurement outcome. So one cannot conclude from gauge invariance alone that the

same number of electrons is transferred in every cycle of the pump.” Physicists needed a new set of ideas to show that the average number of electrons transferred over several cycles was also an integer.

Inspired by Laughlin’s argument, the next attempts at explaining the quantization of the Hall conductance relied heavily on the concept of adiabatic evolution. Adiabatic evolution is a physical process that aims to capture the evolution of a system that remains in its lowest-energy state at all times while some external parameter varies. When the system’s spectral gap—the energy required for it to jump to an excited state—becomes small, adiabatic evolution slows down to prevent the system from crossing over to an excited state. Laughlin’s original argument used this notion to mathematically model the quantum Hall effect as the adiabatic evolution of the electronic state of a quantum Hall system under the increase of a fictitious magnetic flux.

UNBREAKABLE PLAY-DOH

TO STUDY THE QUANTUM HALL EFFECT more deeply, physicists turned to a branch of mathematics called topology. Topology is a way of thinking about the fundamental essence of shapes—the properties that do not change even as they are continuously deformed. Think of a kind of Play-Doh that is unbreakable and impossible to glue onto itself. You can turn a cube of this substance into a ball by rounding out its sharp edges and corners, but you cannot turn it into a doughnut. The latter transformation would require either poking a hole through the cube or stretching and gluing it onto itself. In that sense, cubes and doughnuts are topologically distinct shapes, but cubes and balls are topologically the same (although they are all geometrically different). Topology was formalized in 1895 but had rarely interacted with physics until the 1950s and 1960s.

The initial efforts to understand the role of topology in the quantum Hall effect were considered so significant, in fact, that in 2016 theoretical physicists David Thouless and F. Duncan M. Haldane won a Nobel Prize for this work. Thouless and his collaborators, in particular, extended Laughlin’s argument by showing that the Hall conductance was quantized on average. Because one fictitious flux was not enough to prove quantization, they proposed a second fictitious flux. In the new thought experiment, one flux induced the electric current across a semiconductor, and the other detected changes in the current between pump cycles. This scenario simulated cycles of Laughlin’s pump under distinct initial conditions. The adiabatic evolution generated by the extra fictitious flux played the role of averaging over many cycles of Laughlin’s pump and showed that the average Hall conductance was quantized.

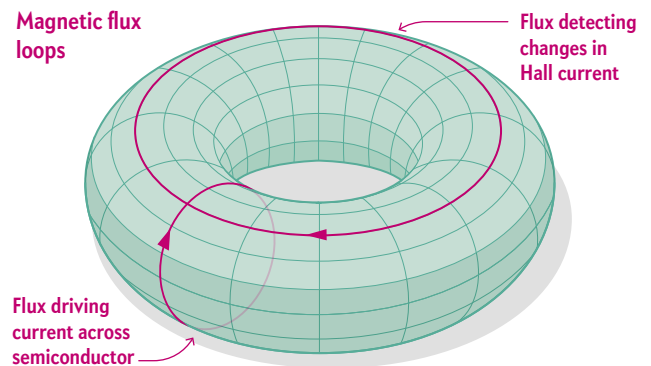

At around the same time, Barry Simon, a mathematical physicist at the California Institute of Technology, noticed that adiabatic evolution formed a mathematical bridge between the Hall conductance and the local curvature of the two-dimensional phase space generated by the two fictitious magnetic fluxes. This local curvature is called Berry curvature after its discoverer, mathematical physicist Michael Berry. In particular, Simon showed that the Hall conductance was equal to $h/2\pi$ times the local curvature at the origin of that phase space. This was a big deal. A famous mathematical result from 1848—the Gauss-Bonnet theorem—declared that the total curvature of a geometric shape was a topological feature, not a geometric one. In other words, the sum of all the local curvatures of a three-dimensional shape is the same for all topologically equivalent shapes with the same surface area. Even more exciting, the total curvature is simply given by $2\pi(2 - 2g)$, where g is the number of holes in the shape.

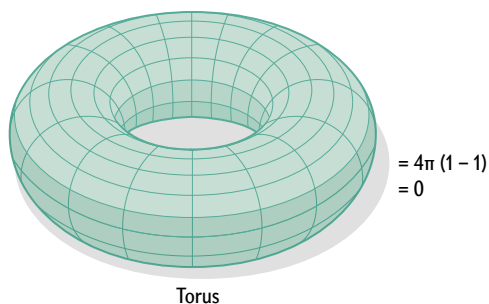
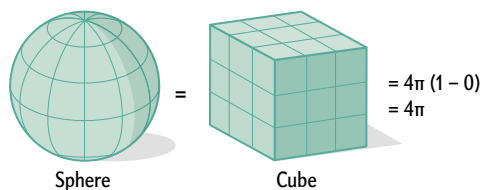
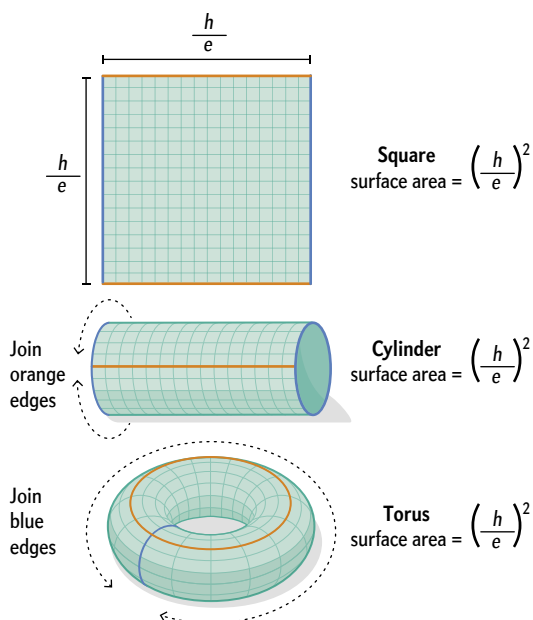

Gauss-Bonnet Theorem
 Total curvature = $4\pi(1 - g)$

Most important for us, a modern generalization of Gauss-Bonnet by geometer Shiing-shen Chern showed that the same result applied for the total Berry curvature of our two-dimensional phase space describing the quantum Hall effect. The Berry curvature of that space was now given by $2\pi C$, with C denoting an integer known as the first Chern number. To show that the Hall conductance was quantized, Simon and his collaborators looked at the average of the conductance over the whole phase space, which is given by $h/2\pi$ times (total curvature) divided by (surface area). Plugging in $2\pi C$ for the total curvature and $(h/e)^2$ for the surface area yielded $C \times e^2/h$. Et voilà. The average Hall conductance was an integer multiple of e^2/h , as Thouless had shown. But for the first time ever, the integer in front of e^2/h was identified with a “topological invariant”—a property that does not change if you rotate or deform a shape—and therefore the result was impervious to small perturbations and imperfections in the physical set-up of the quantum Hall effect. This was a breakthrough insight.

Unfortunately, the beauty of the preceding arguments by Thouless and Simon was marred by a serious issue: the Hall conductance that experimentalists measured corresponded to the local curvature at the origin of the two-dimensional phase space, not the average curvature over the whole space. To see why the local curvature of an arbitrary shape is almost never equal to its average curvature, consider a torus. Gauss-Bonnet implies that the average curvature of a torus, and of any shape with a single hole in it, is zero. But the local curvature of a torus is obviously nonzero along most points on the surface and can take both positive and negative values. Thouless and his collaborators actually tried to address this issue, yet the question remained: Why was the Hall conductance quantized, if one was not allowed to average over all possible initial conditions of Laughlin’s pump? Indeed, that was the question I had to answer.

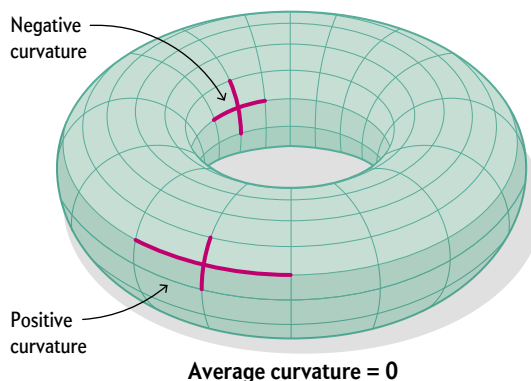

A SENSE OF DESPAIR

MY FIRST STEPS INTO THE MYSTERY of the quantum Hall effect were supposed to be illuminated by a book written by Thouless himself: *Topological Quantum Numbers in Nonrelativistic Physics*. A couple of weeks after receiving the book from Matt, I determined that I did not have the background required to understand any of the physics within. I locked the book inside my desk drawer and put the key away. Yet the book’s simple existence gave me a sense of despair. How could I make any progress in solving the problem if I could not understand the contents of that book? Back then, I was a blank slate.

Of course, I had the option of going to Matt for help. He could teach me what I needed to know. Heck, we could even work close-

ly on the problem together. But about a month or two after I arrived at Los Alamos, Matt told me he was leaving the lab. With job interviews now taking up most of his time, I barely saw him. A few months later, when he was offered a position at Microsoft's Station Q in Santa Barbara, Calif., my interactions with him all but ended. The few times we did meet, I became convinced that Matt had made a serious mistake in giving me a postdoc at Los Alamos. He would speak, and all I could retain were a few word combinations here and there. One of the phrases he repeated was "quasi-adiabatic continuation," a notion I was unfamiliar with. To my further dismay, this term did not seem to appear anywhere in the immense literature devoted to the quantum Hall effect up to that point.

Without much else to go on, I did what every young scientist of my generation would do and googled "quantum Hall effect" and "quasi-adiabatic continuation" (QAC). The first phrase returned

I made progress by breaking the problem down into simple parts I could understand.

hundreds of research papers, but I had as much luck reading through any of them as with the book by Thouless. The one thing I did get out of that search, however, was a word that kept coming up in relation to the quantum Hall effect: topological. When I added that word to my search, the first thing that popped up was an article by Avron, Osadchy and Seiler entitled "A Topological Look at the Quantum Hall Effect." The piece, which appeared in *Physics Today* in August 2003, was meant for nonexpert physicists. This article was so clearly written that it formed the foundation on which I would build my understanding of the quantum Hall effect.

In contrast to the hundreds of articles on the quantum Hall effect, my search on quasi-adiabatic continuation returned just two results, both by Matt. The first paper, co-authored with theoretical physicist Xiao-Gang Wen, was an introduction to QAC. The second paper contained, among other applications, a brief section on using QAC to compute a version of the Berry curvature relevant to the fractional quantum Hall effect. This was the first and only published attempt to apply QAC to any type of Berry curvature. I was excited to study Matt's argument inside and out. But I still needed to understand what QAC was about and how it was connected to adiabatic evolution. So I delved into the first paper, and after a month of poring over it, I felt that I had a good grasp of the technique. QAC was proposed as an evolution of a quantum system designed to preserve certain topological properties of its quantum state. In contrast, adiabatic evolution was better suited for local, geometric properties, such as the Berry curvature mentioned earlier.

The next task was to figure out how to compute the Berry curvature using QAC. To my dismay, I could not parse Matt's brief argument on how the two concepts could be bridged. I decided to re-create that bridge (or my version of it, at least) from scratch. The idea was to follow Simon's argument connecting adiabatic evolution to Berry curvature, while sneaking in QAC in place of adiabatic evolution. Substituting one evolution for the other worked out beautifully for one simple reason: I could show that QAC was exactly the

same as adiabatic evolution under the following special condition: throughout the evolution of the system, the gap in energy between the ground state and the first excited state had to remain above a fixed positive value, independent of the size of the system. As luck would have it, this special condition was satisfied precisely near the origin of the 2-D phase space. In fact, if that condition was violated, I could show that the Hall conductance was *not* quantized.

After going through the exercise of connecting QAC to the Berry curvature and, hence, to the Hall conductance, I turned my sights toward the next big hurdle: re-creating Simon's argument, which computed the averaged Hall conductance as an unchanging topological quantity that yields the first Chern number. This was no small feat. As I have mentioned, to get over the initial problem of simulating adiabatic evolution with QAC, I took advantage of the fact that QAC tracked adiabatic evolution exact-

ly, as long as there was a big enough spectral gap between the ground and excited states of the system. Unfortunately, this assumption about the spectral gap went out the window the moment I started exploring deeper into the 2-D phase space, whose total curvature I needed to compute. In fact, this assumption was so powerful that all attempts to quantize Hall conductance up to that point had used it. In other words, nobody

thought it was possible to prove quantization without making that extra assumption. And neither did I. When I finally reached out to Matt in late spring of 2009 with a solution that made use of that key assumption, he said to me: "Nice job. But I think you should be able to prove quantization without it." Matt pointed me toward a seemingly unrelated paper of his entitled "Lieb-Schultz-Mattis in Higher Dimensions" (LSM), where he had laid the foundations for removing this assumption.

As I began to read through LSM, I had the same sinking feeling as when I had tried to parse Matt's attempt at connecting QAC to the Berry curvature. Deciphering it in isolation was going to be a long and arduous journey. But in a second twist of fate, my Ph.D. adviser, Bruno Nachtergaele, working with one of his postdocs at the time, Robert Sims, had published what some considered a mathematically rigorous version of Matt's LSM paper. Although most of the brilliant insights were already in Matt's original paper, Bruno's version was so well written and thorough that within a month I had a clear view of how to proceed. I now knew how to adapt elements of the LSM argument to overcome the second hurdle: to show that the averaged Hall conductance computed using QAC, instead of adiabatic evolution, was still an integer multiple of e^2/h .

The original Laughlin's pump argument, which used adiabatic evolution and gauge invariance to deduce a return to the original state of the system after one cycle, did not work with QAC. The main problem was that under QAC, after a flux quantum was inserted, there was no longer any guarantee that the system would end up in the same quantum state at the end of a cycle. Adiabatic evolution accomplished such a feat by forbidding the lowest-energy state of the system from ever getting excited. QAC, on the other hand, had a mind of its own. If the spectral gap ever dropped below a critical value as scientists inserted more and more magnetic flux, QAC would happily allow the system to jump to a new, excited quantum state, leaving behind its low-energy past. Unfortunately for me, that meant that at the end of a Laughlin cycle,

even though the dynamics describing the system returned to their original state, the quantum state of the system itself may have changed significantly. If that were the case, then a key element of Laughlin's and Thouless's arguments would go up in smoke.

To overcome this obstacle, I needed to introduce two more fictitious magnetic fluxes in addition to the original two (for a grand total of four), which allowed me to transform the evolution under QAC into one that guaranteed a safe return to the original ground state at the end of a cycle. This trick, borrowed from Matt's LSM paper, forced the state of the system to maintain the exact same energy throughout the modified evolution around the boundary of the 2-D phase space, even when that energy no longer corresponded to the lowest possible energy of the system. In other words, to guarantee the return of the system to its initial state, all one ever needed to know was that the two states had the same energy. The fact that the ground state of the system was uniquely specified by that energy took care of the rest. Adiabatic evolution's insistence on keeping the system in its lowest-energy state throughout the evolution was overkill. More important, as I came to realize later, the insistence on using adiabatic evolution to quantize the Hall conductance was also the reason progress had stalled for nearly two decades.

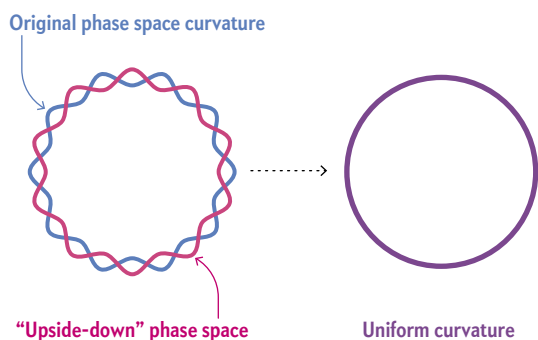

Each of the additional fluxes generated an upside-down version of the phase space so that the new space has uniform curvature.

By now I felt exhausted. But the main hurdle was finally in view. Everything I had accomplished up to this point was a fancy way of showing what Thouless, Simon and their collaborators had already proved: that the averaged Hall conductance was indeed quantized in integer multiples of e^2/h . It would seem that I had made no progress in removing the averaging assumption plaguing every effort to explain the mystery of the integer quantum Hall effect. Except for one minor detail: the two-dimensional phase space generated by QAC had near-perfect uniform Berry curvature. In other words, the real Hall conductance, the one corresponding to the Berry curvature of a tiny patch near the origin of the 2-D phase space, was equal to the average curvature over the total flux space. Because the latter was famously quantized, it followed that the actual Hall conductance was also quantized. *Quod erat demonstrandum*—QED.

This final theoretical hurdle took many months of restless days and sleepless nights to cross over. I nearly gave up several times before reaching my goal. During a particularly dark time, I told my mom that I was not sure I wanted to wake up the next morning. In typical Greek fashion, she responded, "If you do anything stupid, I will fly out there and strangle you with my own two hands." Lost in a world of hyperanalytical thinking, I needed such

an absurd statement to snap me out of it. I finished the proof in November 2009, shared it with Matt, who quickly added a section on how the result could be extended to also explain the fractional quantum Hall effect, and then posted it online. It would take us five more years before getting the result published and another four years before the mathematical physics community could fully digest it. On February 25, 2018, I opened an e-mail from Michael Aizenman—a letter I had waited for eight years to receive. It read:

Dear Matt and Spiros,

The Open Problems in Mathematical Physics web page was now updated with the statement that the IQHE question, which was posted by Yosi Avron and Ruedi Seiler, was solved in your joint work.

I thank you here for your contribution, and also congratulate you on it. It is a pleasure to note that in each of the two problems on which progress is reported there, the advance came through deep novel insights and new tools. The list of solvers is a veritable honor roll.

The fundamental mystery we started with was the question of why a microscopic, quantum phenomenon was showing up on a macroscopic scale. Instead what we found was that one of the most fundamental constants of nature was the reflection of global order beyond our finite grasp—the infinite communing with the infinitesimal. And although we have focused on the theory behind the quantum Hall effect, the experimental efforts it has inspired over the past three decades have been equally, if not more, exciting. Research on topological phases of matter beyond two-dimensional quantum Hall systems is paving the way toward technologies such as large-scale, fault-tolerant quantum computing. Impressive results coming out of labs such as Ana Maria Rey's at the University of Colorado Boulder are even tackling fundamental questions about the very nature of time.

This experience also taught me a valuable lesson: my self-worth is not tied to my success in life. The fateful call with my mom took place three months before I put the finishing touches on the solution. I did not turn into a mathematical genius within the span of a few months. But I made progress by breaking the problem down into simple parts I could understand. To do that, I needed to be okay with feeling incompetent most of the time. Without the faith of my parents in me as a person, whether I was good enough to solve the problem or not, I would have given up right before the finish line. Had I done that, the problem may still be unsolved and Marvel's Avengers would have had to find an even more scientifically implausible way to save the universe than to jump into the quantum realm via a macroscopic portal. ■

MORE TO EXPLORE

Quantization of Hall Conductance for Interacting Electrons on a Torus. Matthew B. Hastings and Spyridon Michalakis in *Communications in Mathematical Physics*, Vol. 334, No. 1, pages 433–471; February 2015. <https://arxiv.org/abs/0911.4706>

Open Problems in Mathematical Physics: http://web.math.princeton.edu/~aizenman/OpenProblems_MathPhys/index.html

FROM OUR ARCHIVES

The Un(solv)able Problem. Toby S. Cubitt, David Pérez-García and Michael Wolf; October 2018.

scientificamerican.com/magazine/sa

ANTHROPOLOGY

Survival of the Friend liest

Natural selection for hypersocial traits
enabled Earth's apex species to best
Neandertals and other competitors

By Brian Hare and Vanessa Woods



Brian Hare is a professor of evolutionary anthropology, psychology and neuroscience at Duke University.

Vanessa Woods is a research scientist and director of the Duke Puppy Kindergarten. Woods and Hare's new book, *Survival of the Friendliest*, was published July 14 by Random House.



WE

ARE THE ONLY HUMANS, BUT NOT SO LONG AGO WE HAD COMPANY. In the roughly 300,000 years of our existence, *Homo sapiens* has shared the planet with at least four other human species. In hindsight, it seems obvious why we prevailed. We were the best hunters, the smartest, the most technologically savvy.

But that is only the story we tell ourselves. Some of the other human species were more technologically advanced, had been around for much longer—a million years—or had brains as big or bigger than ours. Going back 100,000 years ago, if you were to guess which human species was going to make it, one of the other humans, perhaps Neandertals, would have been a good bet.

We shared a common ancestor with Neandertals. They were stronger than us, barrel-chested with muscle. They were highly skilled with weapons and hunted every large mammal in the Ice Age. They even shared with us a variant of a gene known as *FOXP2*, thought to be required for the finely calibrated movements needed for speech. Their culture demonstrated high levels of sophistication: Neandertals buried their dead, cared for the sick and injured, painted themselves with pigment, and adorned themselves with jewelry made of shells, feathers and bone.

The first *H. sapiens* to arrive in Europe met a relatively large population of Neandertals who were well adapted to a cold weather climate. Later, as glaciers advanced, modern humans fled, and Neandertals stayed and thrived. Compared with our closest living relatives, bonobos and chimpanzees, our species

has little genetic variation, which suggests that at some time, perhaps several times, we experienced a severe population bottleneck, which means we might almost have gone extinct.

If we were not the strongest or the smartest, how did we win?

HUMAN SELF-DOMESTICATORS

COMPARED WITH OTHER HUMAN SPECIES, it turns out we were the friendliest. What allowed us to thrive was a kind of cognitive superpower: a particular type of affability called cooperative communication. We are experts at working together with other people, even strangers. We can communicate with someone we have never met about a shared goal and work together to accomplish it. We develop this superpower before we can walk or talk, and it is the gateway to a sophisticated social and cultural world. It allows us to plug our minds into the minds of others and inherit the knowledge of generations. It is the foundation for all forms of culture and learning, including sophisticated language.

This friendliness evolved through self-domestication. Domestication is a process that involves intense selection for friendliness. When an animal is domesticated, in addition to becoming much

IN BRIEF

How did we become the last surviving human species? A hundred millennia ago Neandertals might have had a better chance to prevail.

Homo sapiens outlasted our kindred because we underwent a process of natural selection for friendliness, enabling high levels of group collaboration.

This social sophistication translated into the beginnings of cultural traditions and technologies that left us as the last humans standing.

From Wolf to Dog

An amicable disposition also governed the course of evolution for an animal that turned into a favorite pet

Humans are not the only ones who underwent self-domestication. So did our close relatives, the bonobos, and the species we call our best friend. A tiny fraction of the genome differentiates dogs from wolves, and yet millions of dogs are snugly curled up in our homes, while wolves slink around at the edge of extinction. True, dogs run into doors and drink out of our toilets, but they also protect our loved ones, fight our wars, detect drugs and cancer, calm autistic children, and give many of us unconditional love and a reason to go outside and exercise.

When our research group began its work almost 20 years ago, we discovered that dogs also have extraordinary intelligence: they can read our gestures better than any other species, even bonobos and chimpanzees. Wolves, in contrast, are mysterious and unpredictable. Their home is the wilderness, and that wilderness is shrinking.

But not so long ago the evolutionary race between dogs and wolves was so close, it was unclear who would win. Dogs, in fact, did not descend from wolves. Instead dogs and wolves shared a wolflike ancestor, whom we will call Ice Age wolves to distinguish them from today's animals. These wolves were highly successful: they survived after every large carnivore—saber-toothed cats, cave lions and giant hyenas—had gone extinct. They spread throughout most of the Northern Hemisphere and became one of the most successful predators in the world.

Folklore supposes that humans brought wolf puppies into camp and domesticated them. Or as wolf expert David Mech wrote in 1974, "Evidently early humans tamed wolves and domesticated them, eventually selectively breeding them and finally developing the domestic dog (*Canis familiaris*) from them."

But this story has not held up. Taming an animal occurs during its lifetime. Domestication happens over generations and involves changes to the genome. That is only one difference between domesticating and taming an animal. Even today wolves eat too much meat—as much as 20 pounds in a single feeding—to be a sustainable hunting partner. Ice

Age wolves were much larger than modern wolves. At the time of dog domestication, humans were hunter-gatherers, going out to forage and leaving their children in camp—no sensible human would have let them be unprotected against a carnivore of that size.

Dogs have shorter snouts and reduced versions of the long canine teeth compared with wolves. Their hair changes color to cover them in random splotches. Their tails curl, sometimes in a full circle—and they have floppy ears. Instead of having one breeding season, they can breed throughout the year.

Taken together, these traits are part of the domestication syndrome, an assortment of which appear in a domesticated species. But no one knew what tied these traits together, or if they were related at all, until a Russian geneticist decided to domesticate foxes in a remote outpost in Siberia.

In 1959 Dmitry Belyaev began breeding them using a single selection criterion—whether the fox would approach a human hand. After 50 generations, these friendly foxes would leap into your arms, lick your face and pee for joy.

When our research group tested the foxes, we found that, like dogs, they were better at reading intentions from our gestures. The foxes were only bred to be unafraid and attracted to humans. But other changes, including an increase in social intelligence, happened by accident.

So how did wolves turn into dogs? Back in the Ice Age, as our human populations grew more sedentary, we probably created more trash, which we then dumped outside our camps. These leavings would have included tempting morsels for hungry wolves. Only the friendliest wolves would have been able to scavenge, however. These animals would have had to be unafraid of

humans, and if they displayed any aggression toward us, they would have been killed.

These friendly wolves would have been at a reproductive advantage and, because they scavenged together, more likely to breed together. After generations of selection for friendliness without intentional selection by humans, this special population of wolves would have begun to take on a different appearance. Coat color, ears, tails: all probably started to change. We would have become increasingly tolerant of these odd-looking scavenger wolves and would quickly have discovered that they had a unique capacity for reading our gestures.

Animals that could respond to our gestures and voices would be extremely useful as hunting partners and guards. They would have been valuable as well for their warmth and companionship, and slowly we would have allowed them to move from outside our camps to our firesides. We did not domesticate dogs. The friendliest wolves domesticated themselves.

In the 14,000 to 40,000 years during which this domestication process occurred, wild wolves were probably doing better than dogs in terms of numbers—after all, our dogs were probably another food source for humans when times became lean. The first written record of a wolf hunt was recorded in the sixth century B.C.E., when Solon of Athens offered a bounty for every wolf killed.

This event was the start of a systematic massacre that almost eradicated wolves permanently. In 2003 the estimate of their population was 300,000 worldwide. A 2013 estimate of the population of dogs worldwide totals a billion. The history of dogs and wolves demonstrates how friendliness as a trait translates into a winning evolutionary strategy. —B.H. and V.W.

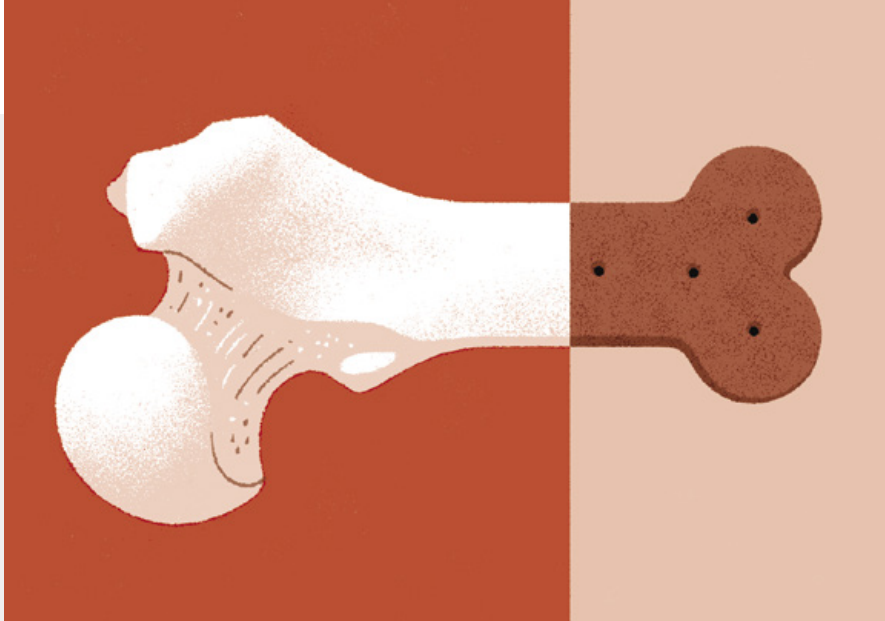

friendlier, it undergoes many changes that appear completely unrelated to one another. This domestication syndrome shows up in the shape of the face, the size of the teeth and the pigmentation of different body parts or hair; it includes changes to hormones, reproductive cycles and the nervous system. Although we think of domestication as something that we do to animals, it can also occur through natural selection, a process known as self-domestication.

The self-domestication hypothesis was developed over the past 20 years from our work with anthropologist Richard Wrangham of Harvard University and psychologist Michael Tomasello of Duke University. What we discovered through our research is that self-domestication also increases the key to our success—the ability to cooperatively communicate with others. The hypothesis predicts that if *H. sapiens* were self-domesticated, we should find evidence of selection for friendliness in the Pleistocene (2.6 million to 11,700 years ago). Although behavior does not fossilize, the neurohormones that regulate behavior shape our skeletons, and we can trace these changes through paleoanthropological specimens.

For example, the more testosterone you have available during puberty, the thicker your brow ridge and the longer your face becomes. Men tend to have thicker, more overhanging brow ridges and slightly longer faces than women, so we call a face with these traits masculinized. Testosterone does not directly cause human aggression, but its levels and its interactions with other hormones do modulate aggressive behavior.

Anthropologists have frequently remarked on the decreasing brow ridges, shortening faces and shrinking heads of humans throughout the Paleolithic. In our own research, we realized that if we documented those changes, they would point to when physiological changes occurred that shaped our behavior and our bodies at the same time.

Together with researchers Steven Churchill and Robert Cieri, then both at Duke, we found that *H. sapiens* prior to the 80,000-year mark, the Middle Pleistocene, had longer faces and much larger brow ridges than in the Late Pleistocene. On average, skulls more recent than 80,000 years ago had a 40 percent reduction in how far their brow ridges projected from the face. They were also 10 percent shorter and 5 percent narrower than the older skulls before that dividing point. Although the pattern varied, it continued so that the faces of modern hunter-gatherers and agriculturalists grew more delicate in appearance, indicating a decrease in testosterone. Another neurohormone, serotonin, may have promoted a set of changes that led to smaller brains and less aggression. Increases in serotonin appear early on during the domestication syndrome—and the chemical may also be involved in skull development.

Drugs that increase serotonin availability in the brain, such as selective serotonin reuptake inhibitors (SSRIs), make people more cooperative and less willing to harm others when tested during social science experiments examining moral dilemmas and cooperation. Serotonin does not just change behavior. If exposure occurs early in development, it also appears to alter skull morphology. Pregnant mice given SSRIs have babies with shorter, narrower snouts and skulls described as globular.

Every other human species had a low, flat forehead and a thick skull. Neandertals had heads shaped like footballs. Only we have the balloonlike skulls that anthropologists call globular. This shape indicates a possible increase in the availability of serotonin during our evolutionary development. Based on the fossil record, these changes started after we split from our common ancestor with Neandertals—and they have continued in the relatively recent evolutionary past. In fact, the work of one of us (Hare) with Churchill and Cieri suggests that our skulls—and hence brain size—have been shrinking over the past 20,000 years.

If testosterone and serotonin levels changed in *H. sapiens* as a result of domestication, another molecule probably did as well. Lower testosterone and higher serotonin enhance the effects of the hormone oxytocin on social bonding. Oxytocin floods through mothers during childbirth. It facilitates milk production and is passed on through breast milk. Eye contact between parents and babies creates an oxytocin interactive loop, making both parent and baby feel loving and loved. When psychologist Carsten de Dreu of Leiden University in the Netherlands and other researchers

Self-domestication is a scientific hypothesis that suggests *Homo sapiens* underwent selection for friendliness—as evidenced by both our behaviors and physical traits.

gave people oxytocin to inhale in an experiment, the subjects tended to be more cooperative, empathetic, and trusting in financial and social games.

All these changes had lasting impacts on our social relationships. In fact, we think these changes produced a new social category: the intragroup stranger. Our evolutionary cousins bonobos and chimpanzees recognize strangers based only on familiarity. Someone who lives with them inside their territory is a group member. Everyone else is a stranger. Recognition is clear-cut. An individual is either familiar or an outsider.

Chimpanzees may hear or see their neighbors, but the interaction is almost always brief and hostile; in contrast, bonobos are friendlier with outsiders. We, too, respond to individuals who are unfamiliar in different ways, but unlike any other animal, we also have the ability to instantly recognize whether a stranger belongs to our group. Only humans can define our groups based on appearance, language or a set of beliefs. Our ever changing conception of group status allows us to recognize those like us—even if we have never met them. It also lets us expand our social network far beyond the size of any other human species.

Every day, without thinking about it, we adorn ourselves in ways that make us identifiable to one another—donning sports jerseys, political pins or religious symbols on a necklace. This capacity dominates our modern lives. It encourages us to per-

form acts of kindness both great and small—donating an organ to a stranger or helping someone cross the street. It also helps us share and improve our best ideas.

THE LIGHTS STAY ON

EVEN THOUGH OUR NEANDERTAL COUSINS seemed to have an edge on us early on, around 80,000 years ago, signs that *H. sapiens* might not just prevail but flourish began to appear.

Glimpses of social sophistication and advanced technology can be found in archaeological remains from when we first emerged as a species in Africa as long as 300,000 years ago. But these sites were like lights blinking on and off. Technology and other signs of progress appeared, then disappeared. After 80,000 years ago these lights seemed to stay on and grow stronger. We think the new category of intragroup stranger appeared in our species around this time, when the fossil record suggests complex cultural traditions and technologies started to spread across long distances. Expanded social networks meant more cultural innovations could be shared at greater speed. Cultural and technological progress exploded.

From 50,000 years onward we began to leave evidence of our expanding social networks and cultural prowess wherever humans lived around the world. Jewelry made from shells has been found hundreds of miles inland, implying that an object with no practical value was either worth carrying some distance or was obtained from someone else who had traveled on one of our first trade routes. We painted animals on rocks so skillfully that the contours of the stone rippled beneath their bodies and seemingly gave them a third dimension.

The idea that friendliness led to our success is not new. Neither is the idea that as a species, we became more intelligent. Our discovery lies in the relationship between the two ideas: it was an increase in social tolerance that led to cognitive changes, especially those related to cooperative communication.

The arrival of human self-domestication would have led to both the increase in population and the revolution in technology we see in the fossil record. Friendliness drove these changes by linking groups of innovators together in a way other human species never could. Self-domestication gave us a superpower, and in the blink of an evolutionary eye, we took over the world. One by one, every other human species went extinct.

This optimistic view of our species is immediately at odds with the misery and suffering we still inflict on one another. If human self-domestication explains the best in us, does it also explain the worst? How do we reconcile our kindness with our cruelty?

Some of the same neurohormonal changes underlying friendliness also support horrific violence. Oxytocin seems crucial to parental behavior and has been called the hug hormone. But a better name would be the momma bear hormone. The same oxytocin that floods through a mother with the arrival of her newborn feeds the rage she feels when someone threatens that baby. For example, hamster mothers given extra oxytocin are more likely to attack and bite a threatening male. Oxytocin is also implicated in related forms of male aggression. Available oxytocin increases when a male rat bonds with his mate. He is more caring toward her but also more likely to attack a stranger threatening her. This link connecting social bonding, oxytocin and aggression is seen widely among mammals.

As our species was shaped by self-domestication, our increased friendliness also brought a new form of aggression. A higher availability of serotonin during human brain growth increased the

impact of oxytocin on our behavior. Group members had the ability to connect with one another, and the bonds among them were so strong, they felt like family. New concern for others came with a willingness to violently defend unrelated group members. Humans became more violent when those we evolved to love more intensely were threatened.

LOVE IS A CONTACT SPORT

DESPITE THE EVOLUTIONARY PARADOXES of human nature, the perception of who belongs in our group is malleable. *H. sapiens* as a species has already demonstrated its capacity to expand the concept of group membership into the thousands and millions.

It can be extended further. The best way to diffuse conflict among groups is to diminish the perceived sense of threat through social interaction. If feeling threatened makes us want to protect others in our group, nonthreatening contact between groups allows us to expand the definition of who our group is.

White children who went to school with black children in the 1960s were more likely, as they grew up, to support interracial marriage, have black friends, and be willing to welcome black people into their neighborhoods.

That formula still works in education. Pairs of roommates at the University of California, Los Angeles, who each were from a different race reported more comfort in mixed-race interactions and approval of mixed-race dating. One study found that imagining positive contact with one of the most dehumanized groups of people—the homeless—helps others to empathize with them. The friendships of individuals from different groups can also generalize beyond their friendship to other group members.

Most policies are enacted with the assumption that a change in attitude will lead to a change in behavior, but in the case of intergroup conflict, it is the altered behavior—in the form of human contact—that will most likely change minds. The self-domestication hypothesis explains why we as a species evolved to relate to others. Making contact between people of different ideology, culture or race is a universally effective reminder that we all belong to a single group called *H. sapiens*.

This gave us the edge we needed to outlast other members in the hominin line. In evolutionary terms, the definition of friendliness relates to positive behaviors, either intentional or unintentional, toward others. It involves not only close physical proximity while group size expanded but also an ability to rapidly read people's intentions. The benefits of social interactions on our species' success—the ability to solve problems better than individuals can on their own—proved so beneficial that it influenced the way selection shaped our bodies and minds. The resulting ability to share knowledge across generations produced the technology and culture that allowed us to populate every corner of the planet. ■

MORE TO EXPLORE

The Genius of Dogs: How Dogs Are Smarter Than You Think. Brian Hare and Vanessa Woods. Dutton, 2013.

Survival of the Friendliest: *Homo sapiens* Evolved via Selection for Prosociality. Brian Hare in *Annual Review of Psychology*, Vol. 68, pages 155–186; January 2017.

FROM OUR ARCHIVES

The “It” Factor. Gary Stix; September 2014.

scientificamerican.com/magazine/sa

EUCALYPTUS TREES soar in KwaZulu-Natal, South Africa. Such plantations grow new wood quickly but can limit biodiversity.





SUSTAINABILITY

THE BIOMASS BOTTLENECK

Strategies for drawing down carbon dioxide depend on more trees, grasses and crop residues than the planet can spare

By Eric Toensmeier and Dennis Garrity

Eric Toensmeier is a lecturer at Yale University and a senior fellow at Project Drawdown and the Global EverGreening Alliance. He is author of *The Carbon Farming Solution: A Global Toolkit of Perennial Crops and Regenerative Agriculture Practices for Climate Change Mitigation and Food Security* (Chelsea Green Publishing, 2016).



Dennis Garrity is chair of the Global EverGreening Alliance. He has served as senior fellow for the World Agroforestry Center and World Resources Institute and as chair of Landcare International.



I

N THE FLAT FARMLAND OUTSIDE DECATUR, ILL., A DUMP TRUCK FILLED WITH EARS of corn rolls into a warehouse at one end of an ethanol plant run by commodities giant Archer-Daniels-Midland Company. The corn is sent into a big fermentation vat that converts it to ethanol, which will be trucked to a refinery that will blend it with gasoline for sale nationwide. The fermentation process releases carbon dioxide, which is captured in a large flue, then sent by pipeline to a wellhead. Pumps send the gas deep belowground, where it will become trapped in sandstone rock.

IN BRIEF

Road maps for limiting global warming to 1.5 degrees Celsius rely too heavily on trees and plants to pull carbon dioxide from the atmosphere.

The chief strategy is bioenergy with carbon capture and storage, but full exploitation would require a continent-sized area of land now used for crops and grazing.

Biomass can play a partial role if greater recycling and more clean cookstoves reduce demand, and several agroforestry techniques increase supply.

This pilot project is about to complete its three-year trial as a novel way to pull carbon dioxide from the atmosphere while providing a viable commercial product that pays the bill. The CO₂ is soaked up by the corn plants as they grow; injecting the gas into the sandstone permanently stores it.

But the use of corn for fuel, which accelerated in the U.S. in the 2000s, is controversial. Corn could feed people and livestock; growing plants for biofuel takes land that could otherwise be used to grow crops. Burning ethanol in cars produces new CO₂ emissions, as does harvesting and trucking the corn. Fermenting, pipelining and injecting all require energy that, in the Midwest at least, may come from fossil fuels. It is unclear whether corn-based ethanol can yield even a small net reduction in atmospheric CO₂.

The Decatur plant is one example of a suite of processes known as bioenergy with carbon capture and storage, or BECCS. Although the facility uses grains, most techniques target woody plants, including trees, shrubs and grasses, which are converted into liquid fuels or burned to create electricity. The emissions from those activities could be sequestered underground or collected and sold as a raw material—primarily for chemical plants or to pump into stubborn oil deposits to force out more oil.

Ignored for the most part 10 years ago, biomass is now being given an important role in the blueprints to lessen climate change. The list of applications is long and growing; in addition to biofuels, it includes biomass burning for electricity and heat, biodigesters that create commercial methane, biochar to improve soil, as well as insulation, building materials and bioplastics. The road maps that depend heavily on biomass include the 2018 *Global Warming of 1.5 °C* report by the Intergovernmental Panel on Climate Change (IPCC) and its 2019 special report *Climate Change and Land*; the U.S. National Climate Assessment released in November 2018; and Project Drawdown's scenarios in its 2020 *The Drawdown Review*. Powerful industries such as electricity, fuel and plastics are betting big on biomass as a feedstock, pushing projected demand sky-high.

The scientific consensus behind the road maps is that to preserve a climate suitable for civilization, global warming should be limited to 1.5 degrees Celsius above preindustrial levels. This requires a 45 percent reduction of emissions by 2030 and zero net emissions by 2050, relative to 2010 levels, according to the IPCC's 1.5 °C report. Humanity's remaining carbon budget—the amount of future emissions that can be tolerated before surpassing 1.5 °C—is 420 billion



COFFEE SHRUBS cultivated in Ecuador's Andes Mountains flourish underneath trees that can provide helpful shade as well as leaf litter to improve the soil.

to 580 billion metric tons. Staying within that limit requires slashing emissions as well as pulling CO₂ from the atmosphere. The IPCC estimates that BECCS could sequester 0.4 billion to 11.3 billion tons a year. Project Drawdown does not include BECCS but calculates an average of 1.1 billion to 2.5 billion tons a year from other biomass applications.

The problem is that most plans assume they can have as much biomass as they want. The truth is that the land needed to produce all that biomass poses a serious constraint. The IPCC reports that large-scale implementation of BECCS alone would require 300 million to 700 million hectares (Mha) of land—an area roughly equivalent to that of India (328 Mha) or the continent of Australia (769 Mha). And most of the land suitable for BECCS is used today for agriculture.

Growing biomass for BECCS at that scale, to say nothing of the other applications, would come into serious conflict with the farmland required to produce food crops and the pastureland needed for livestock. Forests would also be vulnerable because the plans call for cutting them for biomass and replacing them with single-species plantations of high-yielding eucalypts or pines—large monocultures that ruin biodiversity.

It is possible that modest consumption of biomass for carbon sequestration could be sustainable. A few

approaches even improve crop yields as well as woody plant production. But the projected demand is exceedingly high. BECCS is the elephant in the room. The IPCC and other organizations have put almost all their biomass eggs into this one basket, even though there are only about five small BECCS demonstration projects worldwide, according to the Global Carbon Capture and Storage Institute. That is a risky strategy to mitigate climate change.

Greatly increased demand for biomass will further aggravate what has already become a major struggle over how land will be used in the future. Tension is rising over whether more land should be put into soybeans to feed cattle to meet increasing demand for meat, whether cropland should be used to produce biofuels to replace fossil fuels, and how forests can be preserved instead of cut down. Limitless options are not possible on a planet that has inherent limits. A global scramble for biomass has begun, and unless some significant changes in expectations are made, governments and industries will end up colliding.

THE COMING SCRAMBLE

OUR SPECIES HAS ALWAYS RELIED ON BIOMASS to meet basic needs, with virtually no thought about how much we are using. Woody plants have long been essential for

making tools, homes, buildings, ships, mats, rugs, paper and cardboard. Bamboo has more than 1,500 documented uses. Since our earliest days biomass has literally provided the fuel for our fires. More than three billion people still cook over wood fires daily.

In the mid-1800s societies began to shift from wood to fossil fuels for energy, materials and chemicals. This dependency is the basis for civilization's current prosperity but has also brought us to the brink of climate catastrophe.

Most biomass harvested today—more properly called lignocellulosic biomass—comes from trees, bamboo, herbaceous grasses and crop residues such as cornstalks. Biomass has become an attractive climate solution because it is, to some degree, renewable—it can be grown again and again.

BECCS is the dominant source of biomass identified in all the plans. It is still mostly a theoretical pro-

source of 9 percent of anthropogenic emissions. To draw down carbon dioxide and to preserve biodiversity, forests must be protected and expanded, not razed. Project Drawdown's projections are somewhat unique in that they only consider new sources of supply that do not undermine food security or increased forest protection and restoration.

Pathways to 1.5 °C that do not involve BECCS still require unrealistic amounts of biomass. The world's limitless appetite for liquid biofuels is also unsustainable; there simply is not enough cropland to grow feedstock to replace the vast amounts of fuels we use. If 100 percent of all the corn grown in the U.S. was fermented into ethanol, that would meet only 25 percent of the nation's gasoline and diesel demand—and it would leave no corn for people or animals.

To see what level of BECCS deployment might push the world's biomass and food supplies into unsustainable territory, we analyzed the total amount of biomass used worldwide for all purposes in 2015 and then projected demand to 2050, including both low and high levels of BECCS as called for in the major reports. In both scenarios, increasing supply, alone, could not meet demand without deforestation. Reducing demand, alone, could not keep production within the planet's biomass capacity. Only by aggressively reducing certain demands while aggressively increasing certain forms of supply was it possible

Large-scale implementation of bioenergy with carbon capture, alone, would require from 300 million hectares of land—an area roughly equivalent to that of India—to 700 million hectares, the continent of Australia.

cess, capturing CO₂ emissions using the same technology that would scrub the gas from fossil-fuel power plants. The biggest issue is the volume of biomass that would be needed. In its 1.5 °C report, the IPCC states that all pathways that limit global warming to 1.5 °C or 2.0 °C require removing carbon dioxide from the atmosphere, on the order of 100 billion to 1,000 billion tons over the 21st century. Removal includes replanting forests, and farming practices can help sequester carbon in soils and perennial plants, but in the IPCC's scheme, BECCS is cast as the primary tool to stay within the global carbon budget. Converting 300 million to 700 million hectares of cropland to biomass production is simply incompatible with increased food needs.

If food production is not negotiable, it is hard to find significant land. Some previously abandoned cropland could be brought back into production of biomass crops that can grow on that marginal soil, but ranchers and pastoralists already graze livestock on a fair share of this area, much of it being pasture. Meanwhile, to us, cutting into forests to create biomass plantations—something that the big climate plans say is undesirable but inevitable if global emissions are not rapidly reduced—is a nonstarter. Forests are important sinks of carbon; deforestation is already the

to provide the biomass needed—for the case of modest dependency on BECCS [*see box on opposite page*]. Meeting the high-BECCS scenario ended up requiring 450 Mha of land, more than the area of the European Union.

Even the low-BECCS case raises great social concerns. Much of the land needed is now farmed by smallholders, grazed by pastoralists, or home to forests managed by indigenous peoples—land that could be taken against their will. Some 12 million people worldwide have already fallen victim to such land grabs in recent years. Land has been appropriated in Southeast Asia and Brazil to expand oil palm production and in parts of Africa to produce plantation crops such as cacao.

REDUCING THE NEED

LESSENING BIOMASS DEMAND while pursuing some sustainable supply strategies can draw down CO₂ without impacting food production or clearing forests. The first step is to reduce consumption. Worldwide, paper recycling already shrinks demand for pulpwood from forests and plantations by 484 million metric tons (MMT) annually. Project Drawdown predicts that recycling will increase to roughly 1,100 MMT per year by 2050. The project also estimates

Surpassing the Biomass Boundary

2015

Total Biomass Production
3,154 million metric tons (MMT)

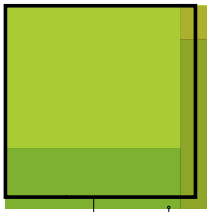

Total Demand
2,749 MMT

405 MMT surplus

- Plantation trees, bamboo and grasses grown on deforested grasslands
- Crop residues
- Forests harvested for timber
- Fertilizer shrubs on cropland

2050 without BECCS

Projected Production
5,150 MMT

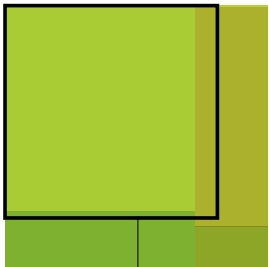

Projected Demand for Traditional Biomass Supplies
3,386 MMT

Greater paper recycling

Clean cookstoves

New demand reductions: 2,382 MMT

Demand for new supplies: 1,945 MMT

- Second-generation biofuels
- Bioplastics
- Biochar
- District heating
- Biogas

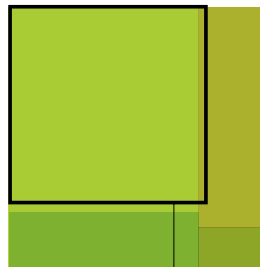

Adjusted Demand
2,949 MMT

2050 with BECCS Added

Low BECCS Demand
(2,100 MMT added, total 5,050 MMT)

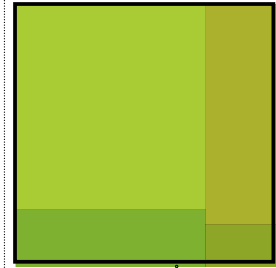

100 MMT surplus

High BECCS Demand
(4,900 MMT added, total 7,850 MMT)

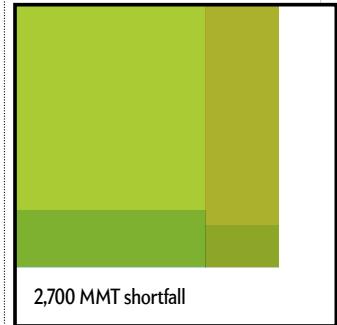

2,700 MMT shortfall

that replacing traditional wood cookstoves with clean cookstoves, of which there are many types, could ease wood consumption by 1,700 MMT by 2050. The stoves can also improve health by diminishing household smoke, an important benefit.

Some biomass wastes that are now discarded as refuse can instead become raw materials for generating energy, including waste from wood processing and from residential landscaping. Crop residues—leftovers such as cornstalks and corncobs that remain after food crops are harvested—could also offer some biomass without changes in land use. Some of it is already accounted for, however: about a quarter of the material now feeds livestock or augments farm practices. Another 50 percent is best left on fields to decompose and rebuild the soil. That leaves only a quarter of annual residues as new raw material.

Together such approaches can take a hefty bite out

of biomass demand. But they do not free up nearly enough biomass to rein in climate change.

INCREASING PRODUCTION

THE SECOND STEP TOWARD providing a sustainable biomass supply is to produce more of it on the same global footprint. Perhaps the most widely promoted approach is a massive expansion of commercial wood plantations—huge groves of eucalyptus, pines and other species. These plantations produce much more wood per hectare than natural forests. But covering large tracts of land with a single species of tree can undermine biodiversity, water quality and flood mitigation. Worldwide, some 294 Mha are already used for wood plantations today, according to the global Food and Agriculture Organization. Adding to that acreage will be difficult because, again, there is only so much land to go around.

Natural forests hold tremendous stores of carbon



BAMBOO GROVES offer a ready supply of biomass for many uses; seen here is the Arashiyama Bamboo Grove in Kyoto, Japan, promoted as a tourist attraction.

in wood and soils, so increased forest protection is important. They are also vulnerable to wildfires, however, and not all carbon that is removed from the atmosphere is permanently sequestered; dead, decomposing trees cycle some of it back into the air.

Some newer techniques for biomass production are scaling up. One of them provides raw material for cellulosic ethanol, in which certain grasses and the stalks of food crops are converted into liquid fuel. Scientists have made progress in finding efficient ways to break down this fibrous material. Farmers are planting big expanses of perennial grasses such as miscanthus and switchgrass for biomass burning and hope to see fuel markets develop. Another strategy, called short rotation coppice, involves planting fast-growing trees such as willows and poplars in extremely dense rows. The trees are harvested every two to three years by heavy equipment that chips the biomass right in the field. The combined growing area of these systems—about 200,000 hectares, according to Project Drawdown—is still small, but the industry is projected to expand greatly.

RELIEF

THERE ARE WAYS to greatly increase carbon sequestration without taking agricultural land out of food production, some of which can actually increase crop

yields. The most widely practiced technique is agroforestry, which integrates shrubs and trees into crop and livestock fields. In France, timber trees and winter grains grow on the same land without competing because the trees leaf in summer and the wheat leaves out in the winter. Farmers there can grow on 100 hectares what would take 130 to 140 hectares to produce if the timber and grain were grown separately.

Woody plants can also be grown in pastures. A particularly promising approach called silvopasture is spreading rapidly in Latin America. Shrubs are planted in dense swaths, which livestock browse for edible leaves, and rows of fast-growing trees such as eucalyptus grow widely apart to leave plentiful grazing space. Intensive silvopasture can increase livestock productivity by double or more while sequestering large amounts of carbon.

Another approach known as evergreen energy is allowing smallholders in the tropics to produce food and wood for energy from the same land. Farmers plant leguminous shrubs such as *Gliricidia sepium* in crop fields. The leafy foliage from the shrubs fertilizes the soil and provides fodder for livestock. The shrub wood is harvested at the end of the dry season for household fuel or for sale to local producers who burn it to generate electricity. The approach can dramatically increase both food production and biomass

GETTY IMAGES

energy and can store carbon every year in the soil and roots. It can also improve farm incomes and jobs in rural populations. Evergreen energy is already widespread in Sri Lanka, is being developed in Africa, and could work well in Asia and Latin America. It would be an ideal way to produce biomass for BECCS, should that technology become available, without sacrificing food production.

Expanded agroforestry has significant potential. Fertilizer trees and shrubs alone are projected to produce 1,200 MMT of biomass by 2050, according to the Global EverGreening Alliance. Agroforestry is already widespread; 43 percent of the world's agricultural land has greater than 10 percent tree cover, most of that located in the tropics. Trees on farms increased 2 percent globally between 2000 and 2010. Millions of farm families throughout the tropics have adopted agroforestry techniques, and more are signing on. The Global EverGreening Alliance has launched a campaign to draw down 20 billion tons of CO₂ annually by midcentury. Realizing this potential, however, will require more sustained support for farmers by agricultural extension.

Despite the efforts of a few dedicated scientists and farmers, agroforestry in the U.S. lags behind the rest of the world. There is no biophysical reason for this lack of application: agroforestry succeeds well in other temperate regions and in U.S. trials. Reluctance is more a matter of mindset in agriculture. Mechanized farming is not a limitation, either; roughly 9 percent of farmland in the European Union is used for agroforestry. Perhaps biomass production can begin at the boundaries of fields and slowly work its way in. (Planting lines of trees along fields to break winds that cause erosion helped to bring the central U.S. out of the 1930s Dust Bowl.) Both France and China have developed systems for integrating trees in large mechanized farms. India is making significant strides as well.

Mechanized farms in places such as the U.S. corn belt could integrate perennial grasses, notably switchgrass and miscanthus. These tall grasses can be grown, harvested and transported to biorefineries that produce fuels or electricity. Precision agriculture technologies are helping farmers identify areas of their fields that are producing food crops poorly and could be better exploited for perennial grasses.

Processing certain grasses for energy can also supply a product called leaf protein concentrate. It is about 50 percent protein and loaded with vitamins and minerals. Though edible by humans, it may be best as a substitute for soy for livestock. Grasses can produce higher yields of this protein per hectare than soy or any other food crop, and because the grasses are perennial, they sequester carbon in the soil.

A WAY FORWARD

IT IS NEITHER POSSIBLE NOR DESIRABLE to plant biomass on an area the size of Australia to meet the demand for BECCS and the other climate solutions. Smarter biomass production and consumption can draw down carbon dioxide without undermining food supply or forests, but it cannot cure our climate ills. The IPCC wisely notes that in the scenarios most likely to limit warming to 1.5 °C, coherent, coordinated policies are needed to enhance food security and limit land-use change. Other rapid and deep transformations will still be needed to zero out greenhouse gas emissions, including reduced consumption by wealthy nations and individuals, conversion to clean energy, and electrification of transportation and industry.

Perhaps we can find inspiration from local people who are already trying to live a smart biomass

Precision agriculture could help farmers grow carbon-storing perennial grasses in underproductive parts of their crop fields, which would be harvested and transported to biorefineries that produce fuels or electricity.

future. Members of the Las Cañadas *campesino* cooperative in Veracruz, Mexico, offer an interesting example. Logging had converted 70 to 90 percent of the region's native cloud forest to pasture. In this mountainous landscape, solar and wind are not promising options. The 20 or so families are using the best biomass practices from around the world to address their needs. They have integrated woody plants into their cornfields and pastures, planted bamboo and fast-growing, resprouting firewood trees, installed 50,000 native trees for reforestation, and adopted wood-conserving clean cookstoves. They are experimenting with a gasifier that burns wood to generate electricity. Member Ricardo Romero estimates a family can meet its annual cooking fuel needs from a plot of roughly 26 by 26 meters. Perhaps the rest of us can learn from the cooperative's vision. ■

MORE TO EXPLORE

Bioenergy and Carbon Capture and Storage. Christopher Consoli. Global CCS Institute, 2019. **Drawdown Review 2020.** Project Drawdown: <https://drawdown.org>.

FROM OUR ARCHIVES

A Cure for Africa's Soil. John P. Reganold and Jerry D. Glover; May 2016.

scientificamerican.com/magazine/sa



“When
my mom
was diagnosed with cancer,
I wanted her
to have access to
the best
treatments
available.”

SONEQUA MARTIN-GREEN
Stand Up To Cancer Ambassador



Photo By
MATT SAYLES

THAT'S WHY I'M SO PASSIONATE ABOUT EXPANDING AWARENESS OF CLINICAL TRIALS

You want the best treatments for your loved ones. My mom's cancer was treated using a therapy made possible by clinical trials. I want all people diagnosed with cancer to have access to the treatments that will make them long-term survivors, like my mom.

Cancer clinical trials may be the right option for you or a loved one. The more information you have about clinical trials, the more empowered you will be to seek out your best treatments.

Learn more at StandUpToCancer.org/ClinicalTrials



nature

outlook

Extracellular RNA

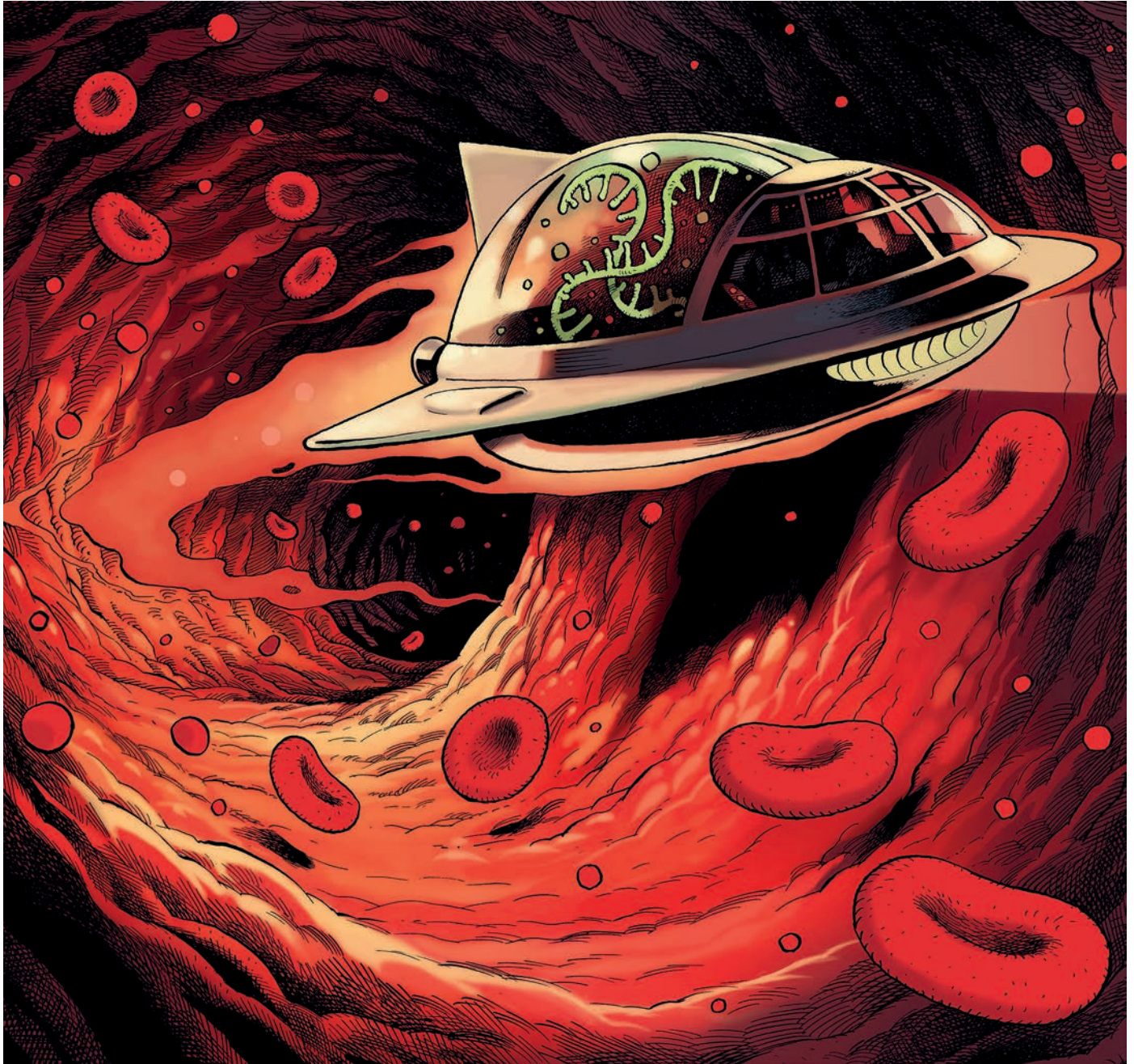

The genetic snippets
shaking up biology

Produced with support from:



The most important stories about the universe and beyond

Journey from quantum to cosmic with
Scientific American Space & Physics

sciam.com/space-physics



Extracellular RNA



For more on extracellular RNA visit www.nature.com/collections/extracellular-rna-outlook

Editorial

Herb Brody, Richard Hodson, Jenny Rooke

Art & Design

Mohamed Ashour, Andrea Duffy

Production

Nick Bruni, Karl Smart, Ian Pope, Kay Lewis

Sponsorship

Helen Zhang, Nada Nabil

Marketing

Rice Song, Pinky Zhang

Project Manager

Rebecca Jones

Creative Director

Wojtek Urbanek

Publisher

Richard Hughes

VP, Editorial

Stephen Pincock

Managing Editor

David Payne

Magazine Editor

Helen Pearson

Editor-in-Chief

Magdalena Skipper

The molecule best known for its part in translating genetic code into protein-assembly instructions is finding a new role in medicine. RNA, once thought to exist only in cells, is now known to travel to tissues all over the body through the blood, under the protection of tiny lipid sacs known as extracellular vesicles. The study of this extracellular RNA (exRNA) has led to a quiet revolution in biology, as scientists endeavour to understand why cells release RNA, and how the molecules might be used to improve the detection and treatment of disease (see page S6).

Eavesdropping on the cellular communications encoded by exRNA could reveal early signs of diseases such as cancer. Various ways to track these extracellular snippets in body fluids are under development (S2). On the therapeutic front, RNA-carrying vesicles might offer a safer and simpler alternative to stem-cell therapy for cardiovascular, neurological and immunological disorders (S16). In particular, researchers are focusing on how to use vesicles that contain RNA to deliver drugs across the barrier that separates the bloodstream and the brain (S14). These natural vesicles have several advantages over the engineered nanoparticles that have received much more research attention (S5).

Beyond the potential clinical applications, exRNA could have intriguing implications for diet. One provocative study that linked RNA in what we eat to gene expression has kick-started vigorous efforts to learn the language in which our food speaks to us (S10). The link, however, remains unproven (S9). Related efforts are focusing on how RNA in breast milk affects infant health (S12).

In plants, a clearer understanding of the biological importance of exRNA is leading to methods to genetically modify some food plants to make them less vulnerable to disease (S19). And researchers across a range of biomedical fields are investigating how best to use exRNA (S20).

We are pleased to acknowledge the financial support of Nanjing University and the NJU Institute of AI Biomedicine and Biotechnology in producing this Outlook. As always, *Nature* retains sole responsibility for all editorial content.

Herb Brody

Chief supplements editor

About Nature Outlooks

Nature Outlooks are supplements to *Nature* supported by external funding. They aim to stimulate interest and debate around a subject of particularly strong current interest to the scientific community, in a form that is also accessible to policymakers and the broader public. *Nature* has sole responsibility for all editorial content — sponsoring organizations are consulted on the topic of the supplement, but have no influence on reporting thereafter (see go.nature.com/2NqAZ1d). All *Nature Outlook* supplements are

available free online at go.nature.com/outlook

How to cite our supplements

Articles should be cited as part of a supplement to *Nature*. For example: *Nature* Vol. XXX, No. XXXX Suppl., Sxx–Sxx (2020).

Contact us

feedback@nature.com
For information about supporting a future *Nature Outlook* supplement, visit go.nature.com/partner

Copyright © 2020 Springer Nature Ltd. All rights reserved.

Contents

- S2 DIAGNOSIS**
Putting extracellular RNA to the diagnostic test
- S5 PERSPECTIVE**
Viva la natural vesicle
- S6 RESEARCH**
Loose translation
- S9 PERSPECTIVE**
Dietary RNA is ripe for investigation
- S10 DIET**
The doubts about dietary RNA
- S12 INFANT NUTRITION**
Unravelling the mysteries of microRNA in breast milk
- S14 THERAPY**
Hacking the body's delivery service
- S16 CELL BIOLOGY**
Inside the stem-cell pharmaceutical factory
- S19 PLANT BIOLOGY**
Planting the seed of RNA crosstalk
- S20 CLINICAL TRIALS**
Research round-up

**On the cover**

A vesicle carrying RNA hurtles through the bloodstream
Credit: David Parkins

This special report
first appeared in *Nature*
[June 18, 2020 | Vol. 582 | Issue No. 7812].



Putting extracellular RNA to the diagnostic test

Tracking RNA in body fluids could reveal early signs of myriad diseases. **By Elie Dolgin**

The body's tissues routinely communicate with each other through RNA messages sent back and forth between cells. So, it seemed obvious to scientists that, by eavesdropping on these extracellular communiqués carried in blood, saliva, urine and other fluids, they should be able to intercept dispatches indicative of health and disease.

If only it were that easy. "When people got into this, we were all a bit naive," says Louise Laurent, a perinatologist at the University of California, San Diego (UCSD).

Laurent is one of a growing number of scientists trying to develop minimally invasive RNA tests for the early detection and clinical management of cancer, heart disease, neurodegeneration and other ailments. But the inherent diversity of extracellular RNA (exRNA) molecules, and the packages that transport them, poses a considerable challenge. "I don't think anybody expected the complications of the biology," says Laurent, whose own research focuses on using exRNA to predict complications in pregnancy.

Heterogeneity of the RNA repertoire can

make it difficult to discern clinically useful biomarkers amid the background molecular noise. And then, to confound matters further, all sorts of technical challenges are associated with the collection, processing and analysis of exRNAs from biological samples. These can make it hard to compare results from different laboratories – a necessary step in the discovery and validation of exRNA biomarkers.

Take, for example, methods for isolating extracellular vesicles (EVs) – envelopes of fatty molecules, typically about one-thousandth the size of a human cell, that protect their cargo from the RNA-degrading enzymes found in most biological fluids. In a study of some 1,700 experiments involving the vesicles, researchers found more than 1,000 unique protocols for extracting them from biofluids¹. The procedural distinctions were often seemingly minor – involving, say, a different rotor type for spinning samples to separate their molecular components. But as study author An Hendrix, a cancer biologist who studies EVs at Ghent University in Belgium, points out, "changing a few parameters can really influence the vesicles that you obtain from a sample."

Research on exRNA for diagnostics has been intensifying over the past five years, and universities and companies are diving into the field in the hope of coming up with medically useful techniques. Making progress on both the biological and technical fronts, scientists have begun to tease apart how RNA molecules find themselves bound up inside EVs and other carriers, and they are discovering what role these molecular missives have under various physiological or pathological conditions.

Thanks to initiatives such as the Extracellular RNA Communication Consortium (ERCC), new methods are also being developed to improve the standardization and reproducibility of exRNA detection. The consortium, a US\$160-million, 10-year programme, was launched in 2013 by the US National Institutes of Health (NIH) to jump-start the clinical development of exRNA-based diagnostics and therapeutics.

Although obstacles to widespread clinical adoption remain – not least, the ability to obtain pure populations of vesicles – some ‘liquid biopsy’ tests that rely on exRNA signatures in biofluids have already hit the market, providing actionable information for patients facing an uncertain cancer diagnosis. Similar diagnostic probes could follow for diseases of all kinds.

“There’s tremendous growth in the field,” says Danilo Tagle, a molecular geneticist who is associate director for special initiatives at the NIH’s National Center for Advancing Translational Sciences in Bethesda, Maryland, and is helping to coordinate the ERCC. “It’s driving companies now to commercialize a number of these approaches.”

Fluid assets

At a laboratory in Waltham, Massachusetts, technicians routinely process thousands of vials of urine each month. They pull out all the EVs from each sample, and then isolate the many RNAs they contain.

This is the home of Exosome Diagnostics, a subsidiary of Bio-Techne and the first company in the world to offer an EV-based diagnostic assay for clinical use. The test, known as ExoDx, is designed for older men whose blood levels of prostate-specific antigen (PSA) are slightly elevated, to help them decide whether to get a biopsy of their prostate.

A prostate biopsy involves inserting a needle roughly the width of a pinhead through the rectum and extracting a small nib of tissue. The procedure often leaves men in pain, with bleeding, infections and bladder trouble. But without a biopsy, it can be difficult to know which individuals with PSA scores in the ‘grey zone’ of 2–10 nanograms per millilitre have

aggressive high-grade tumours that need to be cut out, and whom can safely be left alone. Current estimates are that less than one-quarter of men with middling PSA results turn out to have aggressive cancer.

ExoDx aims to spare more men from invasive biopsies, and the overtreatment that often follows, by quantifying the levels of three particular RNA molecules found in EVs from urine samples. Two relate to genes that encode regulatory proteins – one cancer-promoting and one tumour-suppressing – while the third is associated with a gene that carries the instructions for making a non-protein-coding RNA implicated in prostate cancer development. By assessing these genes’ relative activity, the test is able to estimate an individual’s risk of aggressive prostate cancer.

In two clinical trials involving a total of more than 1,000 men with intermediate PSA levels, the test proved highly predictive of who had a worrying cancer, and so should consider a biopsy, and who had more benign disease and could reasonably opt for a watch-and-wait approach^{2,3}.

“We need the breadth of different diagnostics. One single analyte alone isn’t able to detect all the information.”

The company is expanding into other clinical areas. A second EV-based urine test, now in the works, would predict early which kidney-transplant recipients are at risk of rejecting their donor organs. A blood test to detect gene mutations on the basis of both exRNA and circulating tumour DNA in people with lung cancer is also under development. “This is not just a diagnostic. This is a platform,” says Exosome’s co-founder and chief scientific officer, Johan Skog.

Many other molecular diagnostics firms and academic research teams are also looking at exRNA as a way to spot warning signs of cancer or aid in risk stratification. For example, Cepheid, in Sunnyvale, California, and Pacific Edge, in Dunedin, New Zealand, offer urine tests that measure levels of five protein-encoding RNAs, to identify bladder cancer in its earliest stages or to monitor for signs of post-treatment recurrence. That strategy follows the logic of Exosome’s urine test – collect a body fluid close to the source of the malignancy and probe it for RNA shed by cancer. The same approach has been taken to test spinal fluid for RNAs associated with brain cancer and saliva for RNAs linked to

mouth cancer. But tumours also emit RNAs that spread throughout the body.

Most teams have gone looking for these systemic exRNA footprints in blood. However, David Wong, an oral biologist at the University of California, Los Angeles, has shown that they are detectable in saliva, too. Working with clinical collaborators at the Samsung Medical Center in Seoul, Wong has examined the spit-tle of some 2,500 individuals and identified a saliva signature comprising 9 RNAs – some human, some bacterial – that is highly predictive of who will develop stomach cancer, the most common malignancy in South Korea.

Spit test

Irrespective of the body fluid under consideration, exRNAs might form only part of the diagnostic equation. That’s why Freenome is trying to capture the totality of a tumour’s biology by taking a multiomics approach to the problem of colorectal cancer screening. It is inspecting proteins, DNA, epigenetic biomarkers and other circulating indicators of disease alongside RNA in blood samples.

“We need the breadth of different diagnostics,” says Jimmy Lin, chief scientific officer of Freenome, which is based in South San Francisco, California. “One single analyte alone isn’t able to detect all the information” necessary to unmask cancers lurking in the molecular shadows, he explains.

Freenome scientists reported at a conference this year (see go.nature.com/3ge6wjc) that the company’s platform, which relies on machine-learning algorithms to sift through its reams of biological data, picked up more than 90% of cancer cases – and outperformed an approved stool-based test that is the only current alternative to a colonoscopy in colon-cancer screening. Owing to the unpleasant and inconvenient nature of colonoscopy, many people skip routine testing.

A handful of exRNA-focused start-ups are branching out beyond cancer diagnostics and directing their efforts to diseases of the heart and brain. For instance, Dyrnamix in Lexington, Massachusetts, is developing exRNA diagnostics to personalize treatment for people with cardiovascular disease. Meanwhile, Neurodex, a few kilometres away in Natick, is capturing neuron-derived exosomes from blood, and then scrutinizing the RNAs and proteins inside them in the hope of spotting early indications of Alzheimer’s disease.

“In general,” says Neurodex chief scientific officer Erez Eitan, a neuroscientist by training, “neuro people don’t like RNA.” Unlike cancer, he explains, the pathology of neurological disease is at the protein level – not in the DNA or RNA – and so the research community

outlook



Johan Skog processes samples in Exosome's laboratory in Waltham, Massachusetts.

doesn't know much about the role of RNA in neurodegeneration.

That partly explains why most experimental blood tests for presymptomatic detection of Alzheimer's measure for levels of β -amyloid fragments, activated tau or some other protein whose build-up in the brain has come to define the disease. This strategy, however, is akin to rummaging through someone's rubbish bin to determine how they live, says Victoria Risbrough, a neuroscientist at the Veterans Affairs Center of Excellence for Stress and Mental Health in San Diego, California. A better way of understanding their quirks and idiosyncrasies, Risbrough suggests, would be to read their communications – which is exactly what exRNA represents.

"The RNA gives you a sense of what might be driving some pathology," says Risbrough, who is collaborating with UCSD neuropathologist Robert Rissman to develop diagnostics for traumatic brain injury. "Instead of sifting through the trash, you're looking at their text messages."

Value add

A broad screening test for brain disease remains the ultimate goal. But according to Kira Sheinerman, co-founder and chief executive of DiamiR in Monmouth Junction, New Jersey, the initial customers for most exRNA diagnostics will probably be drug companies running clinical trials of investigational therapeutics.

With DiamiR's panel of brain-enriched and inflammation-associated microRNAs found in blood, for example, Sheinerman and her colleagues have shown that they can predict with 84% accuracy whether an older person with no signs of cognitive impairment will go on to develop Alzheimer's disease. That kind

of information, Sheinerman says, could help drug developers and clinical researchers to better identify people with presymptomatic Alzheimer's who might be good candidates for an experimental therapy that's undergoing clinical evaluation.

"The RNA gives you a sense of what might be driving some pathology. Instead of sifting through the trash, you're looking at text messages."

And even if these exRNA tests never become widely used, "there's value in generating new hypotheses of the disease", says neurologist Joseph Quinn at the Oregon Health and Science University in Portland. Working with molecular neurobiologist Julie Saugstad, Quinn has discovered a series of microRNAs with diagnostic potential for Alzheimer's that could also point to possible biological pathways for future drug development. However, Quinn cautions, the basic science of this process is still not well understood. As a result, his efforts in the field of exRNA diagnostics – like those of so many other researchers – remain in an exploratory phase.

Part of that exploration involves developing tools to refine the methods for isolating EVs. Although some researchers have had success profiling exRNAs without first plucking out EVs from their body fluids of origin, this bulk approach to RNA analysis can often miss subtle signals of biological relevance. So, the field is steadily moving away from total RNA sequencing of human biofluids and towards strategies that zero in on particular vesicles secreted by

organs of interest. "It's homing in on where the signal is," says Saumya Das, a cardiac electrophysiologist at Massachusetts General Hospital in Boston and a co-founder of DYNAMIX.

Conventionally, scientists have attempted to extract EVs by spinning samples in an ultracentrifuge and then relying on differences in size and density between molecular components to obtain the vesicles of interest. But this approach is not perfect. "There's still some contamination," says Esther Nolte-t Hoen, an immune cell biologist at Utrecht University in the Netherlands. "You will not get 100% purity based on size and density."

Techniques in development include filtering EVs through tiny pores of various diameters, or using binding agents to pull target EVs out of a sample. Whatever the method, a validated reference material is necessary for accurate calibration – something that has only recently started to become available.

Last year, for example, Hendrix and her colleagues at Ghent University developed a bioengineered EV that can be spiked into biofluids and then experimentally tracked to help check the accuracy of sample preparation and analytical protocols⁴. "The field has long been searching for such a reference material," says Hendrix, who has shared her traceable EVs with dozens of labs around the world. "After every meeting where I present the technology, I get multiple requests," she says.

Hendrix and others, including Nolte-t Hoen, have also been actively involved in community building and data-reporting initiatives to ensure that studies of RNA-containing EVs, including those focused on disease diagnostics, can be properly interpreted and replicated. "It is maybe not scientifically the most exciting thing to do," Nolte-t Hoen says, "but it's very necessary."

For its part, the NIH, through its massive multimillion-dollar consortium, is now focused on finding better ways to isolate individual EVs and analyse their cargoes. Few exRNA-based diagnostic tests in development today take this level of precision – many don't enrich for EVs at all – and that could be fine for many clinical applications.

But, says Tagle, "to demonstrate rigour, you need to be able to know where your source of information is coming from – and that will, in the end, lead to more robust and reproducible results."

Elie Dolgin is a science journalist in Somerville, Massachusetts.

1. Van Deun, J. et al. *Nature Meth.* **14**, 228–232 (2017).
2. McKiernan J. et al. *JAMA Oncol.* **2**, 882–889 (2016).
3. McKiernan J. et al. *Eur. Urol.* **74**, 731–738 (2018).
4. Geurickx, E. et al. *Nature Commun.* **10**, 3288 (2019).

Perspective: Viva la natural vesicle

Naturally occurring exosomes are ideal for therapies – and are better for the job than artificial nanoparticles, says Philip W. Askenase

Exosomes are a sensational biological discovery. These minute lipid sacs – among the smallest of biological particles known as nanovesicles – are produced and then secreted by all cell types in all animal species. Bacteria produce very similar nanovesicles.

Exosomes are present in all body fluids and seem to be involved in nearly all biological processes. The main function of exosomes is to enter cells, either nearby in the tissues or systemically after transiting through the bloodstream, to deliver the genetic information that they carry. In particular, exosomes transfer microRNAs (miRNAs) – small ribonucleotide polymers of about 22 bases. The extracellular miRNAs carried by exosomes can lead to alterations of DNA in the nuclei of targeted acceptor cells. The modifications to cellular DNA, in turn, alter the production of proteins and, therefore, change cell function. Exosomes are unanticipated universal nanoparticles that can mediate previously undiscovered biological processes, and alter molecular and metabolic pathways of cells and whole organisms.

These universal nanoparticles of life are likely to be of great medical importance. They might give researchers a better understanding of disease mechanisms, lead to new diagnostic tests and, perhaps most importantly, provide a means to deliver new therapies. But this will happen only if researchers study these natural entities more intensively.

Unfortunately, biomedical engineers have instead fixated on a different and less promising avenue: the development of artificial nanoparticles that imitate the function of natural exosomes for drug and small RNA delivery. Compared with naturally occurring exosomes, which have evolved an optimal composition over billions of years, engineered nanoparticles have a number of downsides. Unlike exosomes – which can cross natural tissue barriers such as the blood–brain barrier, can have effects for four to five days after administration and can enter the bloodstream¹ – artificial nanoparticles cannot cross such barriers and are rapidly eliminated by mechanisms that detect foreign entities. Natural exosomes in the blood avoid physiological clearance mechanisms, but engineered nanoparticles are taken up and destroyed.

Exosome membranes are composed of unusual



“Compared with naturally occurring exosomes, engineered nanoparticles have a number of downsides.”

Philip W. Askenase is an immunologist at Yale University School of Medicine in New Haven, Connecticut.
e-mail: philip.askenase@yale.edu

proportions of lipid components that give them a high surface viscosity and rigidity. This composition aids their survival in harsh conditions that kill cells. Such properties might be derived from the ancient origins of exosomes' antecedent vesicles in noxious primordial seas near the beginning of biological evolution – even before the development of bacteria.

Exosomes' remarkable resistance to harsh conditions, such as the acidic and digestive-enzyme-rich environment of the stomach, means that they could be given orally as therapeutics¹. Not only would this be more acceptable to and comfortable for patients, especially children, than intravenous, intraperitoneal and subcutaneous routes. But oral administration has also been shown to be a superior delivery method in mice.

Their stability and resilience are only part of what makes exosomes a natural choice for delivering genetic and anti-inflammatory molecules as therapies, both locally and systemically. They also lend themselves to therapeutic use in numerous other ways. It is likely that exosomes can be isolated from healthy individuals, and that a biologically active subpopulation can easily be enriched by a purification method called antigen or antibody affinity chromatography to promote therapy. Exosomes can also, in some instances, be used across species, without concern for immunological or genetic incompatibility, because miRNAs are often universal. Exosomes from plants might even have some medical use. And because exosomes do not contain full-length DNA, they are unlikely to cause cancer.

Exosomes also have an advantage over artificial drug carriers when it comes to targeting. Some exosomes can bind to selected antigen-specific antibody chains on their surfaces². This gives exosomes an unrivalled ability to specifically target acceptor cells expressing particular surface antigens. Their uniquely targeted gene-altering miRNA cargo is also simple for researchers to load because activated exosomes can associate with miRNAs of choice by mere incubation³. Exosomes could therefore be used both to battle pathogens and to facilitate gene therapies for a variety of disorders.

Research indicates that exosomes might be effective therapies for diseases such as cancer, multiple sclerosis, rheumatoid arthritis, stroke, spinal-cord injury, myocardial infarction and lung fibrosis. Furthermore, investigations have begun into the use of exosome therapy for neurological conditions such as Alzheimer's disease, Parkinson's disease and even autism spectrum disorder. However, much more work is needed before RNA-carrying exosomes can fulfil their therapeutic potential. One important task is to determine the nature of the surface molecules on exosomes that allow them to bind to targeting antibodies, as well as the molecular arrangements that allow them to also associate with selected therapeutic RNAs. Artificial nanoparticles do not have these capabilities. Now is the time for researchers to usher in a new era of therapeutic possibilities using RNA-delivering, natural exosome vesicles.

1. Wąsik, M., Nazimek, K., Nowak, B., Askenase, P. W. & Bryniarski, K. *Nutrients* **11**, 907 (2019).
2. Bryniarski, K. et al. *J. Allergy Clin. Immunol.* **132**, 170–181 (2013).
3. Bryniarski, K. et al. *PLoS ONE* **10**, e0122991 (2015).



Juan Pablo Tosar analyses extracellular RNA from samples that had been spun in a centrifuge.

Loose translation

A serendipitous finding by a researcher in Uruguay uncovered protein-making machinery outside the cell – a discovery that has scientists rethinking fundamental assumptions. **By Roxanne Khamsi**

If Juan Pablo Tosar hadn't been so forgetful, he would never have stumbled across a finding that threatens to upend a basic tenet of cell biology. In 2016, two months after he was awarded his PhD, in a laboratory at the Pasteur Institute of Montevideo in Uruguay, Tosar was tasked with processing samples of breast cancer cells. The aim was

to discard the cells and membrane-bound structures so that researchers could study just the molecules that existed in the fluid between cells. To separate out the unwanted components, Tosar had to spin the samples in a centrifuge. According to the standard protocol, he should have cooled the centrifuge's removable rotor to 4 °C to protect the samples

from degrading. "The correct way of doing that is putting it in the cold room the night before," he says. "Sometimes I forgot, so it was not as cool as should be." He still went ahead with the experiments, however. "I said, what's the difference?" he recalls. "But there was."

When Tosar cooled the rotor sufficiently, the results from the analysis showed a tiny



peak indicating the presence of large RNA molecules in the extracellular space, where they were not expected to be. But when he forgot the cooling step, that small peak would disappear. The anomaly stirred his curiosity.

Tosar had an inkling that the explanation could be something big – quite literally. There are many types of RNA, and the biggest ones form ribosomes. These structures are essential apparatus that other kinds of RNA load onto to turn genetic code into proteins, and it is a basic tenet of biology that they function only inside cells. But what if these crucial protein factories were also floating around in the extracellular space? The data from Tosar's accidentally too-warm centrifuge pointed to this possibility.

Trying to understand how things work and thinking outside the box has always been in Tosar's nature. As a 14-year-old boy growing up

in Uruguay, his hobby was to create computer games, such as a poker game in which the players could cheat by taking extra cards. But, one day, his parents took the computer to be repaired, and the person at the shop mistakenly erased all the data. The episode pained Tosar so much that he swore never to have a career in computer science, and ultimately turned to biology.

His career path eventually led him to the Pasteur Institute of Montevideo, where he met his mentor, biologist Alfonso Cayota. Cayota was trying to work out the part RNA plays in cell communication. RNA is best known for its role in helping cells turn their DNA blueprint into proteins through a process known as translation – within the confines of the cell membrane. But Cayota's group was looking at extracellular RNA (exRNA), which exists outside the cell membrane. Growing evidence suggests that cells use exRNA to influence one another.

As a PhD student in Cayota's lab, Tosar examined every kind of exRNA he could find. At the time, many researchers were focused on exRNA inside tiny membrane structures found throughout the body called extracellular vesicles (EVs). EVs – which include a small type known as exosomes – are released by cells into the extracellular space. But Cayota and Tosar took a different approach. They decided to investigate exRNA found outside these structures. In 2015, they and their colleagues reported that various types of exRNA existed independently of exosomes¹. The assortment included transfer RNA (tRNA) molecules, which are important for ferrying the amino-acid building blocks of proteins to the ribosomes. The researchers' follow-up experiments showed that tRNAs could persist in a stable conformation outside both cells and exosomes².

It was around this time that Tosar had the curious results from the centrifuges that he had forgotten to cool. And he was determined to work out what was causing them. Finding it difficult to obtain essentials, such as certain reagents, in Uruguay, he secured a three-month stint to accelerate the work at the laboratory of Pavel Ivanov at the Brigham and Women's Hospital in Boston, Massachusetts. He convinced his wife, a paediatrician, to uproot their life and move there with their toddler and three-month-old infant in the spring of 2019. For the next few months, Tosar attempted to confirm that the structures were in fact ribosomes.

To amplify the signal of ribosomal RNA, Tosar added compounds known as ribonuclease inhibitors to the samples, which block naturally occurring enzymes from

digesting RNA. When he did so, the small peak of ribosomal RNA became huge. It suggested that ribosomal RNA exists in the extracellular space outside of vesicles, albeit fleetingly before the body's natural enzymes get to work. His findings, which were posted on the preprint server bioRxiv in January³ and are under consideration for publication in a journal, also detail how these extracellular ribosomes are activated when mixed with the energy-carrying molecule ATP – suggesting that they have the potential to produce proteins outside cells.

"These are thought-provoking data," says Esther Nolte-*t* Hoen, whose lab at Utrecht University in the Netherlands studies extracellular signals. "The possibility that protein translation occurs outside cells may have been overlooked until now because cell-culture conditions are often not permissive for ribosomes to remain stable."

"That the possibility exists is incredibly exciting," Tosar says. The work is still preliminary, and needs to be replicated by other groups. But if proteins are synthesized in the space between cells, this would mean that cells have even more ways to communicate with each other than biologists thought. Drug makers could also take advantage of this phenomenon by delivering the genetic template for protein drugs directly to extracellular ribosomes. "Sometimes I feel like the great discoveries were made decades ago," Tosar says, "but when you see stuff like this you feel like there's a whole world to explore."

Package deal

Pick up any biology textbook and you will find an account of the discovery of the structure of DNA in the 1950s, and how scientists worked out that certain kinds of RNA serve as a copy of that information. For many years, it was thought that all this genetic information was carried inside cells. But within a few decades, researchers began to challenge this simple view.

In 1983, a couple of years before Tosar was born, two papers were published describing the presence of tiny vesicles outside cells^{4,5}. Soon after publication, the co-author of one of these seminal papers, biochemist Rose Johnstone, coined the term exosome. However, these discoveries faded into history, and it wasn't until 1996, when researchers at Utrecht University discovered exosomes being churned out by immune cells⁶, that the field started to blossom.

But even then, some scientists pushed back against the suggestion that these vesicles contained RNA. Many simply refused to accept that living cells were systematically

outlook

releasing genetic material. Jan Lötval, who studies exosomes at the University of Gothenburg in Sweden, remembers the scepticism he faced when, in 2007, he reported that exosomes could shuttle RNA between cells⁷. He recalls that others scoffed at his suggestion that living cells not only release genetic material but also receive these packages from other cells. This sort of signalling between cells was a concept that people struggled to accept. Biologists knew about nerves pinging each other with electrical signals, and chemical messengers such as hormones triggering distant cells. But the idea that packages of nucleic acids were shared between cells suggested a whole new realm of cellular communication. “I lost grants when we published this,” Lötval says. Funders were reluctant to support the follow-up experiments he proposed. Now, however, the paper has been referenced upwards of 5,000 times and is a seminal study in the field.

“When you see stuff like this you feel like there’s a whole world to explore.”

Cayota heard about Lötval’s findings on extracellular genetic material and decided to encourage members of his lab, including Tosar, who was embarking on his graduate studies, to hunt for signs of this, too. Meanwhile, other scientists started producing data hinting that ribosomal components might be present outside cells. In 2009, a group at Pohang University of Science and Technology in South Korea found signs of ribosomal subunits inside the EVs that are present in the fluid around colorectal cancer cells⁸. The following year, a group at Harvard Medical School in Boston, Massachusetts, found ribosomal components in vesicles in human urine⁹. And last year, researchers found indirect evidence of ribosomes in the extracellular space. They discovered strands of extracellular messenger RNA, or ex-mRNA, that were longer than expected. This, the scientists wrote, “indicated that ex-mRNA fragments are ribosome protected”, meaning that some physical association with ribosomes might have shielded them from degrading enzymes¹⁰.

Tosar’s search for extracellular ribosomes outside of vesicles built on this work. What is notable about his research, however, is that he found not just fragments of ribosomes, but also evidence of fully intact ones. His peers say that Tosar is forming a case for researchers to pay more attention to the

potential significance of genetic machinery in the extracellular space. “I think it’s a very big deal,” says molecular biologist Kenneth Witwer, who studies exRNA at Johns Hopkins University in Baltimore, Maryland, and who has collaborated with Tosar in the past. “He’s someone I really respect as a thinker.”

Roger Alexander, a senior scientist at the Pacific Northwest Research Institute in Seattle, Washington, has also noticed Tosar’s work. “He’s leading the charge in what I think is a very important area that has not gotten enough attention in our field,” Alexander says. “There’s a lot of interesting biology and clinical potential there.”

Till death do us part?

One big question that Tosar is struggling with is where the ribosomal material in his samples coming from. Are the structures actively packaged and sent out by living cells? Or are they a by-product of a dying cell, spilling out into the extracellular space with the rest of the cell’s contents as its membrane falls apart? “It could be that we’re just seeing the garbage that cells are releasing into the extracellular space,” Tosar says.

Witwer says that the fact that ribosomes are relatively big makes it hard for him to imagine how they would be expelled from cells without being carried out in a large EV. For that reason, he thinks that the main source of ribosomes floating independently in the extracellular space would be from cell death. Indeed, in 2006, scientists reported a correlation between the number of destroyed cells and the amount of extracellular ribosomal RNA in experiments with a human bladder cancer cell line¹¹.

Ribosomes do not have much protection from enzymes that degrade them outside cells. So exactly what biological function they could have extracellularly is unclear. Free-floating exRNA outside cells typically disappears “in a matter of seconds” owing to the action of enzymes such as ribonucleases, Witwer explains. “Let’s just say that in the extracellular space, the ribonucleases are winning,” he says. Tosar speculates that if ribosomes are released into the extracellular space when cells die they could be acting as a signal to the immune system that something is amiss. Ribosomes are unusually large complexes – 30 nanometres across, whereas other common proteins such as albumin are about 4 nanometres. Their size might make them easier for immune cells to detect, thereby triggering some sort of protective response.

Witwer thinks that the signal of exRNA could also prove useful to physicians as a biomarker of disease (see page S2).

To ensure that exRNA – including extracellular ribosomes – sticks around long enough to be useful, Witwer predicts that technicians taking blood from patients will immediately mix the samples with inhibitors to block the enzymes. The exRNA that is thereby saved from degradation could provide information on cell signalling or cell death in diseases such as cancer.

Even though Tosar’s data suggests that the extracellular ribosomes he found have the potential to be activated, he still has a lot more work to do to prove that they can turn mRNA into proteins. It’s important to discover whether ribosomes outside the cell can do this – if they can produce proteins, this could hypothetically serve as a new signalling system between cells, or even alter the cellular matrix that serves as the backbone for tissue architecture. One of Tosar’s ongoing experiments is to separate the ribosomes out to see whether mRNA is still loaded onto them.

Many exRNA researchers still remember their struggles to get the wider scientific community to accept their early discoveries, so they are open-minded to the ribosomal findings from Tosar and his colleagues. Lötval, remembering the scepticism he faced when he first reported his own results on exosomes, says “I should give them the benefit of the doubt, this is certainly something that could prove to be biologically important.”

Tosar knows that the idea of ribosomal RNA floating in the space between cells is unsettling for most biologists because it challenges the long-standing view that all of the cell’s machinery is contained within its membrane. And the evidence from his serendipitous uncooled rotor experiment is preliminary. But he wants people to consider the possibility that machinery such as ribosomes might not be so neatly packaged up inside cells. The extracellular space could really be just an extension of the cell itself. If exRNA doesn’t remain boxed in, then neither should our thinking.

Roxanne Khamsi is a freelance science journalist in Montreal, Canada.

1. Tosar, J. P. et al. *Nucleic Acids Res.* **43**, 5601–5616 (2015).
2. Tosar, J. P. et al. *Nucleic Acids Res.* **46**, 9081–9093 (2018).
3. Tosar, J. P. et al. Preprint at bioRxiv <https://doi.org/10.1101/2020.01.29.923714> (2020).
4. Pan, B. T. & Johnstone, R. M. *Cell* **33**, 967–978 (1983).
5. Harding, C., Heuser, J. & Stahl, P. J. *Cell Biol.* **97**, 329–339 (1993).
6. Raposo, G. et al. *J. Exp. Med.* **183**, 1161–1172 (1996).
7. Valadi, H. et al. *Nature Cell Biol.* **9**, 654–659 (2007).
8. Hong, B. S. et al. *BMC Genomics* **10**, 556 (2009).
9. Miranda, K. C. et al. *Kidney Int.* **78**, 191–199 (2010).
10. Akat, K. M. et al. *JCI Insight* **4**, e127317 (2019).
11. Böttcher, K., Wenzel, A. & Warnecke, J. M. *Ann. N. Y. Acad. Sci.* **1075**, 50–56 (2006).

Perspective: Dietary RNA is ripe for investigation

RNA in food could have profound effects on the human digestive system and on health more generally, says Kenneth Witwer.

In the mid-nineteenth century, German philosopher Ludwig Feuerbach reviewed a monograph on the influence of food chemicals on the make-up and function of the body. In his essay, he asserted that food affects even cognition, coining the phrase: “you are what you eat”. To change the world, give people better food, he said.

The study of nutrition has progressed substantially since then. How the body extracts molecular building blocks and energy from food is well understood. But could food be more than just fuel? In 2012, an article suggested just that: a dietary component that interacts with the genetic code.

The authors of the study¹ reported that short molecules of RNA called microRNAs (miRNA) from rice accumulate in tissues, and regulate an important liver enzyme. This regulation was so effective that, surprisingly, a plant-based diet seemed to significantly boost levels of circulating cholesterol in mice. This, and other reports from the same group on dietary-RNA-containing particles, including extracellular vesicles (EVs), generated considerable excitement.

But despite numerous replication and analysis studies, little or no systemic uptake of dietary RNA has been observed. A faithful replication of the initial experiments, but comparing mice given a nutritionally balanced rice-based diet with animals fed just rice, showed that the cholesterol finding was not the result of miRNA transfer, but rather a starvation response to a nutritionally insufficient rice diet². In a study this year in cows, researchers found that during the 24-hour window after birth in which calves can absorb antibodies from their mother’s milk, proteins and lipid membranes transferred readily into the circulation – but RNA did not³.

However, systemic transfer, which involves molecules crossing multiple barriers in the body, is not the only way that dietary RNA could affect health beyond serving as fuel⁴. Dietary-RNA carriers have access to the epithelial and immune-surveillance cells of the alimentary tract. They probably also interact with the diverse species of the community of microorganisms that live in the gut.

Such interactions could be exploited to deliver therapeutic small RNA strands to combat specific health conditions. Early evidence of the transfer of RNA from one organism to another came from the finding that bacteria, given orally, could transfer therapeutic RNA to



“The mechanisms of delivery and the use of RNA in the recipient cell must be unravelled.”

Kenneth Witwer is a molecular biologist at Johns Hopkins University in Baltimore, Maryland. e-mail: kwitwer1@jhmi.edu

human colorectal cancer cells transplanted into mice⁵. The bacteria don’t need to replicate to have these effects, so bacterial EVs could be a safer and highly scalable alternative to live organisms. And bacterial vesicles are not the only possible delivery vehicles. Indeed, food plants, blended and broken up into nanoparticles that resemble EVs, could deliver RNAs and small-molecule drugs to epithelial cells⁶. Food-based RNA-delivery strategies are likely to be very low risk, because there is no evidence that dietary RNA is harmful.

Particles produced from these plant ‘smoothies’ might affect the gut microbiome – just as host epithelial EVs have been shown to do – and RNAs could play a part in this phenomenon. Because the health of the microbiome is now a recognized factor in conditions such as cancer and neurodegenerative disease, the effects of dietary RNA and EVs should be investigated more intensively. Theoretically, dietary RNA found in food or engineered RNA additives could attenuate or eliminate pathogens by targeting essential genetic elements. It could also be used to fine-tune the balance of microbes in the gut, because different RNA molecules exert different effects across the diverse gut-microbe populations.

In his essay, Feuerbach opined that the uprising of the German people had failed because they ate too many potatoes. A diet richer in beans, he thought, would have brought about political change. Such a notion now seems quaint, and bolstering a person’s political activism through dietary microRNA is a far-fetched idea.

Nevertheless, opportunities abound to study whether dietary RNA is delivered to the cells of the alimentary tract and the microbes that live there. But these investigations must include appropriate controls to determine whether dietary extracellular RNA is mostly a source of nutrition in the form of molecular building blocks or whether specific RNA sequences are transferred into microbial or host gut cells where they regulate other nucleic acids.

If the latter is true, researchers will need to determine whether native dietary RNA is therapeutically effective, or if it is necessary to introduce vesicles loaded with naturally occurring or synthetic RNA. Similarly, can a ‘smoothie’, or even unprocessed food, deliver RNA, or must EV-like particles be separated and concentrated from these sources?

Finally, the mechanisms of delivery and the use of RNA in the recipient cell must be unravelled. Knowing exactly how RNA is taken up and incorporated into regulatory complexes will allow researchers to exploit and enhance these pathways. Although it is not possible to predict how these experiments will turn out, the findings could lead to the use of specific foods and methods of processing as therapy or to enhance gut health.

Depending on the outcome, Feuerbach’s ideas might turn out to be correct on a molecular level he could not have anticipated.

1. Zhang, L. et al. *Cell Res.* **22**, 107–126 (2012).
2. Dickinson, B. et al. *Nature Biotechnol.* **31**, 965–967 (2013).
3. Kirchner, B., Buschmann, D., Paul, V. & Pfaffl, M. W. *PLoS ONE* **15**, e0229606 (2020).
4. Cai, Q., He, B., Weiberg, A., Buck, A. H. & Jin, H. *PLoS Pathog.* **15**, e1008090 (2019).
5. Xiang, S., Fruehauf, J. & Li, C. J. *Nature Biotechnol.* **24**, 697–702 (2006).
6. Zhang, M., Wang, X., Han, M. K., Collins, J. F. & Merlino, D. *Nanomedicine* **12**, 1927–1943 (2017).

The doubts about dietary RNA

Scientists are grappling with the radical idea that microRNAs from food could directly affect human gene expression. **By Kristina Campbell**



Huang-Ge Zhang has shown that nanoparticles from grapes can deliver therapeutic RNA.

Until September 2011, Janos Zempleni's main focus was working out how the bodies of mammals use chemical compounds such as vitamins. But new research published online at the time changed that.

Zempleni, a molecular nutritionist at the University of Nebraska–Lincoln, like many others in the field, was struck by the findings of an astonishing study published in *Cell Research* suggesting that food could provide something other than nutrients – information from ingested plants could switch mammalian genes on and off¹. In the study, researchers reported that microRNAs (miRNAs) – very short fragments of non-coding RNA molecules – originating from plants such as rice had been found in the bloodstream of mice, cows and humans. And in a mouse model, one particular rice-derived miRNA seemed to reach the liver, where it directly inhibited the expression of a gene that normally serves to clear 'bad' low-density lipoprotein cholesterol from the blood. After learning about the work, Zempleni was keen to follow up on the

possible transfer of genetic material from dietary components, and to determine how extensive this phenomenon might be.

When Kenneth Witwer, a molecular biologist at Johns Hopkins University School of Medicine in Baltimore, Maryland, read the paper, he immediately realized the potential significance of the work. "I thought, wow, this is amazing. I want to do this, too." He remembers thinking, "maybe this is some evolutionarily conserved way that we can extract something else from our food other than just nutrition." He corralled some of his lab's resources and set about trying to verify the findings in a small animal study of his own.

But misgivings about the *Cell Research* study soon began to surface. Not only were Witwer and several others unable to reproduce the findings, but some of its basic premises were also called into question. Scientists doubted that diet-derived miRNAs could make it into the systemic circulation of animal hosts at sufficient levels to have a meaningful impact. Follow-up work² also revealed the strong possibility that the 'diet-derived' miRNAs were

actually the result of contamination.

Initial excitement about the possible health effects of rice-derived miRNAs gradually tapered off. Some researchers, including Witwer, gave up studying it altogether. But others persevered with the idea that what we eat can directly affect gene expression. What's at stake is a clearer understanding of how humans relate to, and derive benefit from, their food.

A tall glass of exosomes

Zempleni, after a brief and disappointing spell looking for broccoli-specific miRNAs in humans, turned his attention to miRNAs in milk. "We settled on milk because of the importance for infant nutrition and because Americans consume lots of milk," he says.

Zempleni wondered whether the miRNAs in milk go beyond the gastrointestinal tract. But he quickly encountered a problem: the miRNA molecules themselves rapidly degraded in the gut. "We realized what matters is really not just the miRNAs," Zempleni says. "What's at least equally important is the shell in which these miRNAs are packaged." This shell is a bubble-like vessel called an exosome. "In order for miRNAs to be bioavailable and to be absorbed from the gut, they have to be encapsulated in these exosomes," Zempleni says. As others had shown, fragile miRNAs need to be protected in these containers to be transported from cell to cell.

The exosomes accounted for how the miRNAs could remain intact in the host's digestive tract, but the next challenge was to work out how they end up in different places in the body. As a way of testing whether the milk miRNAs could go beyond the mouse gut, Zempleni and his colleagues devised a method for labelling the miRNAs contained in cow's milk exosomes with fluorescent compounds. These could then be tracked in animal models. "This technology confirmed that these microRNAs, if encapsulated in exosomes, accumulate in various tissues," he says – mainly the brain, liver and intestinal mucosa³.

This established that the miRNAs could reach not just local sites (the gut wall), but also distant ones. Turning, then, to the question of how the miRNA-containing exosomes were affecting host health, Zempleni carried

out various experiments in which he gave mice a diet deficient in both free miRNAs and miRNA-containing exosomes, and compared them with other mice consuming a diet that had normal levels of each. He found a range of effects, including a decrease in the cognitive performance⁴ of mice receiving the depleted diet, a decrease in fecundity⁵ and changes in muscular growth⁶.

Zempleni is now tackling the question of whether these health effects are conferred by the dietary miRNAs or something else, such as the entire exosome or a component of the exosome besides miRNAs. He and his colleagues are looking at a group of mice engineered to lack miRNAs in their milk. Initial unpublished results show that their offspring, whose diet consists only of their mother's milk, have numerous health and developmental problems. If confirmed, this would specifically implicate the diet-derived miRNAs as major players in health – at least, those in milk during early life.

Zempleni says that “miRNAs and exosomes are way more bioavailable in milk than in plants”. He speculates that this might have evolutionary underpinnings: “Nature may have made them to be bioavailable because of infant nutrition,” he says (see page S12). Zempleni is investigating other foods of animal origin, and, as part of an ongoing study, he is looking at whether he can track how dietary chicken-egg exosomes deliver miRNA cargo to mouse tissues.

A gut feeling

Some of Zempleni's animal-model work is based on the idea that exosomes interact with the gut microbiota – the community of microorganisms involved in the health effects conferred by a host's diet. This led to the hypothesis that the gut microbiota might mediate cell-to-cell communication between milk exosomes and mammalian hosts.

It's in this realm that Witwer predicts much of the progress in the field will occur over the next few years. “We can shift our focus from the circulation and the tissue of the animal, to the gut,” says Witwer. He thinks that interactions of diet-derived exosomes with gut epithelial cells or particular gut microbes hold promise.

The gut has also been a central focus for researchers studying the extra-nutritional health effects of dietary plants. Immunologist Huang-Ge Zhang at the University of Louisville in Kentucky is pursuing the question of how plant foods, such as grapefruit, carrots and mushrooms, might affect specific cells. He studies the plant equivalent of exosomes, entities called exosome-like nanoparticles, which are protective vesicles with similar precious

cargo inside: protein, lipid and RNA. In 2018, Zhang reported how ginger exosome-like nanoparticles are stable in the intestine, and how they regulate gut bacterial composition⁷.

According to Zhang, when introduced into mammals, exosome-like nanoparticles can home in on different cells in the intestine with remarkable specificity. He has shown, for example, that exosome-like nanoparticles from grapes are taken up by gut stem cells⁸, and that nanoparticles from grapes, ginger, carrots and grapefruit target gut-associated macrophages⁹.

Zhang's view is that the miRNAs in these exosome-like nanoparticles might have been incorrectly singled out in earlier work as responsible for host health effects. Because exosome-like nanoparticles consist of numerous proteins, lipids, RNAs and polysaccharides, says Zhang, they might do many things at once. “Multiple factors carried by a single nanovesicle can be taken up by the same cells,” he says. “Therefore, we can see multiple molecules as regulating multiple pathways.”

Zhang hopes that, by learning which host cells (in the gut and elsewhere) preferentially take up different plant-derived exosome-like nanoparticles, researchers could assemble new nanoparticles for use as drug-delivery vehicles to very specific cell types in the body. Having abandoned his own studies on milk exosomes around 2008, he says that plant nanoparticles have several distinct advantages over exosomes of animal origin. Not only are exosome-like nanoparticles safer because they avoid possible transfer of cow-derived pathogens, but they are also more versatile – drug developers looking to target a particular cell type can explore the exosome-like nanoparticles derived from thousands of different types of plant, each with its own target in the host. Furthermore, Zhang says, purification of milk exosomes is particularly challenging, and large quantities of exosomes are more expensive to produce than are plant nanoparticles.

Molecular biologist Jiujiu Yu, also at the University of Nebraska–Lincoln, became interested in the therapeutic potential of plant-derived vesicles because they could be extracted in large numbers from various plant foods. In particular, she wanted to know how vesicles affected metabolic inflammation and obesity. Her lab developed a cell-culture system to screen dietary exosome-like nanoparticles from ginger or mushrooms to find out how they affected the cells implicated in inflammatory processes related to metabolic disease.

Yu is focused on identifying the part of the exosome-like nanoparticle responsible for anti-inflammatory effects. Her latest work, which has not yet been published, has shown

that only in rare cases is the RNA component necessary for the anti-inflammatory effects of the vesicles. She wants to explore the possibility that, for a given food, any part of the exosome-like nanoparticle could be responsible for a health effect. “People try to focus on miRNA because it's a new component,” Yu says. “Protein and lipids are not that exciting. But we should try to study all these components of the vesicles, not just focus on something that catches the eye.”

“If you load milk exosomes with cancer drugs, you could deliver them to tumour sites in cancer patients.”

Yu thinks there is much more still to learn before exosome-like nanoparticles from plants are put to therapeutic use in humans. Her lab has found that ginger purchased from different grocery stores contains different exosome-like nanoparticles that yield different results¹⁰. The vesicles can have strong or mild anti-inflammatory effects, or even promote inflammation. “There's inconsistency, so we need to be very careful if we want to just use those dietary vesicles for therapeutic use,” she says. “I really want to identify the active molecule.”

Zempleni, meanwhile, sees applications for milk exosomes on the horizon. “If you load milk exosomes with cancer drugs, you could deliver them to tumour sites in cancer patients – even if the drugs themselves are not very bioavailable or not very stable,” Zempleni says. “That's a big story these days.” Indeed, Pure-Tech Health of Boston, Massachusetts, in collaboration with pharmaceutical giant Roche, is already working to advance technology that uses milk exosomes for drug delivery.

The ultimate goal is to learn the language in which our food speaks to us – and to discover whether miRNAs might serve as a Rosetta Stone.

Kristina Campbell is a freelance science journalist in Victoria, British Columbia.

1. Zhang, L. et al. *Cell Res.* **22**, 107–126 (2012).
2. Tosar, J. P., Rovira, C., Naya, H. & Cayota, A. *RNA* **20**, 754–757 (2014).
3. Manca, S. et al. *Sci. Rep.* **8**, 11321 (2018).
4. Mutai, E., Zhou, F. & Zempleni, J. *FASEB J.* **31**, abstr. 150.4 (2017).
5. Mahrou, S., Xie, F., Wood, J. & Zempleni, J. *FASEB J.* **30**, abstr. 673.5 (2016).
6. Parry, H. A. et al. *Front. Physiol.* <https://doi.org/10.3389/fphys.2019.00436> (2019).
7. Teng, Y. et al. *Cell Host Microbe* **24**, 637–652 (2018).
8. Songwen, J. et al. *Mol. Ther.* **21**, 1345–1357 (2013).
9. Mu, J. et al. *Mol. Nutr. Food Res.* **58**, 1561–1573 (2014).
10. Chen, X., Zhou, Y. & Yu, J. *Mol. Pharm.* **16**, 2690–2699 (2019).



MicroRNAs in breast milk might have a role in regulating development in babies.

Unravelling the mysteries of microRNA in breast milk

A decade after microRNAs were found in mother's milk, scientists are still trying to work out why they are there and how they affect health. **By Tien Nguyen**

A mother's milk is a comestible marvel. It's packed with nutrients and other benefits for babies' health. A steady stream of research has linked breastfeeding to lower risk of infection, obesity, diabetes and respiratory disease in infants.

Scientists are busy investigating how exactly breast milk provides these protective effects. Researchers have a good grasp of how many of the nutrients it contains, such as fats and vitamins, affect infant health, says Steven Hicks, a paediatrician at Pennsylvania State University College of Medicine in Hershey. But

breast milk is a complex blend of numerous bioactive molecules, and the contribution of all components is not yet clear.

"Our knowledge base about breast milk and how it provides health benefits is constantly evolving," says Hicks. "Every time we think that we've got it figured out, a scientist comes along and finds a new molecule that we didn't know was there", or that we didn't realize was important, he says.

One such molecule is microRNA (miRNA) – short, fragile strands of RNA made up of around 22 nucleotides and found inside protective extracellular vesicles called exosomes.

Once overlooked as genetic junk, miRNA is now attracting attention as an important player in regulating gene expression. By attaching to matching strands of messenger RNA, which is involved in protein synthesis, miRNA can effectively turn mRNA off and on, and alter what proteins are made.

It was not until 2010 that miRNAs were found in breast milk¹. Researchers suspect that the molecules have a role in regulating important aspects of infant development, such as immune function. If this is true, miRNAs could be added to infant formula so babies fed this way don't miss out on the health benefits. But before this can happen, researchers must answer basic questions about the molecules – including whether miRNA can even survive in the gut.

Food versus function

Bo Lönnerdal, a biochemist at the University of California, Davis, has spent decades studying the bioactive components of breast milk. When Lönnerdal learnt that researchers had found miRNAs in breast milk, he remembers wondering what the molecules were doing there. There must be a reason why these seemingly random bits of RNA are present in milk, he recalls thinking.

To explain their existence, researchers came up with two theories. The first, known as the nutritional hypothesis, proposes that miRNAs are just convenient packages of nutrients – much like one of breast milk's major proteins, serum albumin – that are broken down in the gut. The second, dubbed the functional hypothesis, suggests that miRNAs have a regulatory role and affect an infant's gene expression.

One way to work out whether miRNA is more than just molecular baby food is to determine whether it is broken down during digestion or if it survives to influence cells in the gut wall and beyond. In 2017, Lönnerdal and his colleagues explored this question by exposing miRNA-containing exosomes from breast milk to acidic conditions that mimic those in the infant gut and observing how the packages fared².

"They survive quite well," Lönnerdal says – the exosomes protect the otherwise vulnerable miRNA from being degraded. The team also found that when the exosomes were incubated with human cells, the miRNAs made their way into the nuclei of cells, where the molecules could affect gene expression.

Not everyone agrees with the conclusion that miRNAs can survive the conditions in the stomach. Researchers at the Swiss Federal Institute of Technology Zurich (ETH Zurich) found that miRNAs were not present in the

digestive organs or the bloodstream of mice at biologically relevant levels³. But it has been argued that miRNA could be active in very low amounts, and further research has supported the idea that miRNAs can withstand acidic conditions. To resolve the matter once and for all, researchers, including Hicks, are designing clinical studies of breastfed infants. A study to detect intact miRNA in babies' stool is already under way.

Cataloguing mother's milk

The issue of whether miRNAs survive aside, so far scientists have mostly been identifying common miRNAs in breast milk, and then working out which biological processes they might affect. The first part is fairly easy: miRNAs can be isolated from breast-milk samples. After that, "it's a bit of a guessing game", Hicks says.

Once researchers have read the 22 or so base pairs of a strand of miRNA, they can match it to a complementary mRNA, he explains. That mRNA might code for a protein involved in a key biological process, such as immune function or metabolism.

The issue, however, is that mRNAs are much bigger than miRNA. So a single miRNA might match 20–50 mRNAs, Hicks says. Scientists are using software algorithms to whittle down their results – weeding out imperfect matches that are off by one or two base pairs, or searching the literature to find previously reported matches between a specific miRNA and mRNA.

So far more than 1,400 miRNAs have been identified in breast milk, according to a 2019 review⁴. Several studies have linked the major miRNAs present in breast milk to regulation of immune responses.

One article reported that miRNA-148a is highly expressed in mother's milk⁵. This particular miRNA has been shown to suppress the activity of genes in tumour cells involved in proliferation, leading the authors to speculate that miRNA-148a has a protective effect against cancer in infants. One of the paper's authors, Regina Golan-Gerstl at Hadassah Medical Center in Jerusalem is now investigating whether miRNA-containing exosomes can travel beyond the gut to reach other organs through the bloodstream. Using fluorescent labelling, her team has detected exosomes in the liver and brain of mice, suggesting that miRNA can reach cells in other parts of the body and possibly regulate their gene expression. Another study has already shown that miRNAs in cow's milk can reach the liver and brain in mice⁶.

Hicks' team has found that the miRNA strands found in the breast milk of mothers who give birth at full-term differ from those

seen in the milk of mothers who give birth to premature babies. The researchers showed that milk from mothers who delivered early is richer in the miRNAs that target mRNA involved in metabolism⁷. This suggests that the miRNA composition of a mother's milk changes to help her baby grow faster in order to catch-up growth, Hicks says. Research has shown that milk from mothers with preterm infants has a higher concentration of macronutrients such as protein and fat.

Such findings could have implications for the health of preterm babies, Hicks says. Mothers of premature babies sometimes can't breastfeed because their bodies have not yet started producing milk. Preterm babies in intensive care units are often given donated breast milk from a milk bank. The banks include full-term and preterm milk, but donations are currently not labelled with this distinction. Hicks suggests that changing this practice so that physicians can consider giving premature babies milk donated by mothers who had a preterm birth could make a difference to the development of these infants.

Baby steps

Establishing a direct connection between miRNA and infant health could pose ethical challenges. A conventional clinical trial normally includes a control group, meaning that some infants would receive miRNA and some would not. Although scientists don't know for sure that miRNAs improve babies' health, Lönnerdal says, it's hard to imagine an ethics panel approving a trial that withholds potentially beneficial molecules from a cohort of infants.

Instead, researchers might be limited to observational studies. In February, Hicks' team enrolled its 185th mother–baby pair in a clinical study funded by the non-profit Gerber Foundation in Fremont, Michigan. The study will ultimately include more than 200 participant pairs. The trial, which started in 2018, measures levels of miRNA found in breast milk, infant saliva and infant stool over 12 months. It also tracks the health of infants – specifically whether they develop food allergies, eczema or asthma.

Hicks says that his group is looking for associations between high levels of particular strands of miRNA in breast milk that survive digestion and protective effects against such conditions in babies. The group's results could be a first step towards singling out miRNAs that affect babies' health. Confirming miRNA's mechanism of action will require more basic science, Hicks says.

If the evidence shows that miRNAs are

beneficial, he says, the last step would be to add the molecules to baby formula. But given that the formula industry's consumers are infants, introducing additives into products will be difficult. Indeed, two ingredients – the human milk oligosaccharides 2'-fucosyl-lactose and lacto-N-neotetraose – that first

“Our knowledge base about breast milk and how it provides health benefits is constantly evolving.”

showed infant health benefits more than a decade ago, including improving gut health, were added to formula in the United States only in 2016 and in Europe in 2017.

Lönnerdal predicts that it will be harder for molecules such as miRNAs to gain acceptance because of their origin in cancer research – miRNA dysregulation is linked to certain types of cancer. “If you google microRNA, which a lot of parents will do, you will get cancer, cancer, cancer,” he says. Although the formula industry has expressed some interest in miRNA research at scientific meetings, he says, the market appeal of these molecules could impact its decision to move ahead with research.

If formula companies did decide to add miRNA, these molecules could be isolated from animal sources, says Golan-Gerstl. Research from her group has shown that around 90% of miRNAs found in human milk are also found in that of cows and goats⁵. Given many people's preference for products labelled as natural, an animal-derived molecule might be more acceptable to the public than synthetic versions, and stand a better chance of approval, she says.

But putting miRNA into formula does not have to be the only focus for the field, Golan-Gerstl says. Uncovering the health benefits of milk miRNA could be valuable information in and of itself. Breast milk could hold more surprises for us still.

Tien Nguyen is a science journalist in Washington DC.

1. Kosaka, N., Izumi, H., Sekine, K. & Ochiya, T. *Silence* **1**, 7 (2010).
2. Liao, Y., Du, X., Li, J. & Lönnerdal, B. *Mol. Nutr. Food Res.* **61**, 1700082 (2017).
3. Title, A. C., Denzler, R. & Stoffel, M. *J. Biol. Chem.* **290**, 23680–23691 (2015).
4. Benmoussa, A. & Provost, P. *Compr. Rev. Food Sci. Food Safe.* **18**, 703–722 (2019).
5. Golan-Gerstl, R. et al. *Mol. Nutr. Food Res.* **61**, 1700009 (2017).
6. Manca, S. et al. *Sci. Rep.* **8**, 11321 (2018).
7. Carney, M. C. et al. *Pediatric Res.* **82**, 226–236 (2017).



Hacking the body's delivery service

Researchers are taking advantage of nature's extracellular-vesicle network to deliver RNA therapies. **By Amanda B. Keener**

When Lydia Alvarez-Erviti started her postdoctoral studies at the University of Oxford, UK, in 2008, her goal was to develop gene therapies for neurodegenerative diseases. She had identified her target – α -synuclein, a protein that accumulates in the brains of people with Parkinson's disease – and designed a short interfering RNA (siRNA) to reduce the amount of α -synuclein made in mice. But she needed to get the siRNA into the brain. The method would have to protect the RNA, cross the barrier between circulating blood and the brain, and be safe enough to use repeatedly. Fortuitously, a colleague had begun studying something that could work – naturally occurring, nano-sized vesicles called exosomes.

Exosomes are 30–100-nanometre-wide

lipid spheres that are used by cells throughout the body to transfer small molecules such as microRNA (miRNA). Optimized to travel in the body without attracting undue attention from the immune system, each tiny package is “an ideal drug carrier”, says Juliane Nguyen, a bioengineer at the University of North Carolina at Chapel Hill.

Around ten years ago, Alvarez-Erviti, who is now at the Center for Biomedical Research of La Rioja, Spain, and her colleagues proved exosomes' potential as drug carriers in a mouse model of Parkinson's disease¹. Now, a large body of work in animals, along with early studies in people, has demonstrated the proficiency and safety of exosome products.

Exosomes are expensive to isolate from other types of extracellular vesicle (EV),

and they naturally carry diverse, often uncharacterized, material. In terms of safety and standardization, these complexities place exosome-based therapies somewhere between cell therapy and treatment with small-molecule drugs. But these challenges have not deterred Alvarez-Erviti's team or the other research groups and companies working to standardize and scale up EVs for use in people. “When you work with exosomes,” she says, “you need to have to have a lot of gumption.”

The natural alternative

For RNA and small-molecule drugs, getting inside cells is a major bottleneck for reaching targets. The body has measures in place to keep foreign material out of cells, including cell membranes and RNA-degrading enzymes.

Biotechnologists have come up with various workarounds. Synthetic nanoparticle carriers or empty viruses, for example, are often used to protect drugs from degradation and to promote their entry into cells. Among the most popular carriers are liposomes – spheres of lipid molecules, usually 100–200 nanometres in diameter, that can fuse with the cell membrane to deliver their cargo. But in high doses, liposomes can damage cells, and both liposomes and viral carriers can trigger immune reactions after repeated administration. These drawbacks have led many to consider exosomes as carriers – the RNA transport service that the body already has in place.

“When you work with exosomes, you need to have to have a lot of gumption.”

Exosomes are regarded as safer than artificial vesicles because they already circulate through the body. Researchers have found that exosomes can be administered to cells in the lab without causing cell death, and repeatedly injected into mice without causing inflammation². Alvarez-Erviti harvests exosomes from immature immune cells because vesicles from these cells don't have immune-activating molecules on their surfaces. Exosomes from mesenchymal stem cells are also popular because stem cells tend to avoid immune detection.

Like most nanoparticle drug carriers, exosomes accumulate mainly in the liver, lungs and spleen. But they also show an affinity for the tissues they were originally collected from. Bioengineer Ke Cheng at North Carolina State University in Raleigh found that when exosomes harvested from fibrosarcoma cells are injected into tumour-bearing mice, the vesicles are drawn to the tumours³.

This homing characteristic means exosomes can deliver more of the drug to where it is needed, reducing the potential for side effects. Cheng's team reported that loading a liposome-based chemotherapy drug called doxorubicin into cancer-cell exosomes increased the amount of the drug that reached the tumours. Treatment with exosome-encased doxorubicin also shrank the tumours to a greater degree than did doxorubicin alone.

Vesicles from some non-cancerous cells also have useful homing abilities. According to Steven Stice, a stem-cell biologist at the University of Georgia, Athens, and co-founder of nearby biotechnology company Aruna Bio, exosomes from a human neuronal stem-cell line called ABI26 cross the blood-brain barrier and home in on sites of injury. And some researchers

are engineering exosomes to increase their retention in certain tissues. For example, Alvarez-Erviti's team genetically engineered cells to produce exosomes bearing rabies-virus proteins on their surface and that caused the vesicles to accumulate in the brain where the receptor for the protein is found.

Peptides that direct vesicles to desired tissues can also be chemically linked to exosome surface proteins or embedded into vesicle membranes – an approach that could speed up their preparation in clinical settings. Cheng's team, for example, used a commercially available phospholipid reagent to slip a peptide known to home to heart cells into exosome membranes. This increased exosome accumulation in the hearts of rats induced to have heart attacks⁴.

Controlling the contents

When Alvarez-Erviti began to work with exosomes, she already had a therapeutic molecule for them to carry. But EVs are naturally filled with proteins, RNAs and lipids. Although their biological activity is largely uncharacterized, some seem to be therapeutic in their own right.

Researchers are working to identify the therapeutically active molecules inside exosomes and use them in new treatments. Cheng's team has found a human exosomal molecule, called miRNA-21-5p, that reduces the rate of heart-muscle cell death and improves blood-vessel growth and tissue repair after heart attacks in mice. The team's long-term goal is to generate exosomes with high levels of the miRNA and a cardiac cell homing peptide. These superexosomes, as Cheng calls them, would be administered through the bloodstream immediately after a heart attack.

One way to load EVs with therapeutic cargo is to disrupt vesicle membranes with electrical current or chemicals to allow drugs to enter. Another option is to genetically engineer vesicle-forming cells to make an RNA or protein drug before vesicle formation. However, there's no guarantee that an engineered cell will load the desired cargo into its vesicles. “The cells decide what to encapsulate,” says Young Kwon, a biomedical and materials scientist at the University of California, Irvine.

Nguyen's team is studying how cells make those decisions, to find ways to ramp up exosome loading with artificial cargo. Researchers have identified strands of code common in natural exosomal RNAs that probably play a part in packaging the molecules. And Nguyen has found that copying some of these molecular codes onto other RNAs increases their loading into exosomes by up to 100-fold. She plans to use the technology to load breast cancer

exosomes with miRNAs that block blood-vessel formation and cancer spread.

Another route to control vesicle content is to force their formation through physical or chemical manipulation of cells. Kwon's team chemically coaxes cells to pinch off membrane-bound pieces of themselves called blebs that, compared with naturally occurring EVs, are more homogeneous in size and content. Any RNA made by a cell should be distributed into the blebs randomly. Such cells can be made to produce ten times as many blebs as they can vesicles – and in hours instead of days⁵.

A new biologic

EVs are challenging to turn into commercial products for the same reason that they have so many advantages – they have to come from living cells. Most companies are using a few well-characterized cell lines to produce all their exosomes. Stem cells are a natural choice, because they can be cultured for a long time and do not produce an immune response. Cells produce the most exosomes when grown in suspension rather than on a flat surface, says Jan Lötval, who studies exosomes at the University of Gothenburg, Sweden. But stem cells must adhere to something to grow, so some companies use spherical microcarriers suspended in media – an approach that can increase exosome production 20-fold.

Firms also need to improve methods for purifying EVs from cell-growth media on a large scale – much bigger than in academic labs. Lötval says that manufacturing issues such as these are surmountable, but will make EVs an expensive option for delivering therapies. There is also no clear path to approval yet. Cheng says drug regulators such as the US Food and Drug Administration have yet to release guidance on how these vesicles can be tested for safety and potency. For now, researchers and companies test them batch by batch, each using different assays depending on the drug they're developing.

Creating artificial exosomes could sidestep these challenges. But researchers still need to work out how exosomes are made and why they are so effective at infiltrating cells and evading immune detection. Only after they answer these basic questions will this new mode of drug delivery be ready for clinical service.

Amanda B. Keener is a freelance science writer in Littleton, Colorado.

1. Alvarez-Erviti, L. *et al. Nature Biotechnol.* **29**, 341–345 (2011).
2. Izco, M. *et al. Mol. Therapy* **27**, 2111–2122 (2019).
3. Qiao, L. *et al. Theranostics* **10**, 3474–3487 (2020).
4. Vandergriff, A. *et al. Theranostics* **8**, 1869–1878 (2018).
5. Ingato, D., Edson, J. A., Zakharian, M. & Kwon, Y. J. *ACS Nano* **12**, 9568–9577 (2018).



Researchers at the Paracelsus Medical University in Salzburg, Austria, prepare extracellular vesicles.

Inside the stem-cell pharmaceutical factory

Vesicles secreted by stem cells might give clinicians a safer and simpler alternative to cell therapy, but researchers are still grappling with how best to prepare and study these tiny particles. **By Michael Eisenstein**

It all seemed so straightforward at first. Stem cells are renowned for their capacity to develop into a wide range of other cell types, and researchers have spent decades exploring the notion that adult stem cells could be transplanted to form healthy new tissue in diseased or damaged organs.

But by the early 2000s, it had become apparent that stem-cell biology was more complicated than initially believed. Michael Chopp, a neuroscientist at the Henry Ford Health System in Detroit, Michigan, was among the first to explore the potential for adult stem cells – most notably a subtype known as either

mesenchymal stem or mesenchymal stromal cells (MSCs) – to mitigate the effects of spinal-cord injury, stroke and other neurological trauma. “We looked at what’s really going on, and we knew that the cells were not actually replacing the tissue,” says Chopp. Rather, he and others hypothesized, these cells were repairing tissue by means of secreted factors.

Today, the evidence points strongly to exosomes – a class of tiny membrane bubbles known more generally as extracellular vesicles, which routinely bud off from cells and carry within them a cornucopia of biomolecules including RNA, proteins and lipids. “We found

very quickly that we can recapitulate what the MSCs do, with the vesicles that are derived from MSCs,” says Mario Gimona, head of good manufacturing practice at the Paracelsus Medical University in Salzburg, Austria.

Accordingly, many erstwhile cell-therapy researchers have shifted gear to explore whether exosomes might deliver the same clinical benefits without the potential risks associated with infusions of living cells, such as immune rejection or tumour formation. The early data hint at the potential to mitigate cardiovascular, neurological and immunological disorders. But exosome researchers are

also coming to terms with the limits of their knowledge about how and why these little blobs work.

A medicinal mixture

Exosomes were first described in the late 1980s, and researchers subsequently teased out their role as a means of communication between cells. But it was only in 2010 that Sai-Kiang Lim, a cell biologist at the A*STAR Institute of Molecular and Cell Biology in Singapore, homed in on exosomes as the enigmatic secreted factor underlying MSC-mediated tissue repair¹.

Initially, Lim was surprised. She had expected the causative factor to be a protein or small molecule, so the identification of these strange vesicles sent her scrambling back to the literature. “The exosomes discovered us, rather than us discovering exosomes,” she says. But the finding made sense: exosomes tend to be laden with non-protein-coding RNA molecules that can strongly modulate gene expression. “Any given type of extracellular vesicle might contain more than 30,000 different species of noncoding RNAs,” says Eduardo Marbán, a cardiologist at Cedars-Sinai Medical Center in Los Angeles, California. This payload – alongside the diverse proteins and other biomolecules also found in exosomes – make these tiny droplets a potent engine for regulating cell biology.

Marbán’s group demonstrated in 2014 that blocking the release of exosomes by heart-derived stem cells eliminated the cells’ therapeutic effects in injured mouse hearts². At around the same time, exosomes made their clinical debut³. Dietrich Beelen, a transplant doctor at the University of Duisburg-Essen in Germany, was interested in using MSCs to treat a patient with severe graft-versus-host disease (GVHD). This condition arises when transplanted bone marrow triggers a damaging immune response against the host tissue that can ultimately lead to organ failure and death. Some studies had indicated that MSCs might quell this immune backlash, but Beelen was concerned about the uneven track record of these cells in the clinic. So he teamed up with colleague Bernd Giebel, a stem-cell biologist, to dose a patient with MSC-derived exosomes instead. The results were remarkable: the patient’s inflammation subsided dramatically, and she achieved a greatly improved quality of life that persisted until she ultimately died from possible steroid-related complications. “She was stable for more than four months,” says Giebel.

The treatment was a one-off, permitted on compassionate grounds. In subsequent years, exosomes have seldom been tested in

the clinic. But the preclinical data consistently indicate the feasibility of using exosome-based treatments to manage not just GVHD but a host of disorders.

Ashok Shetty, who studies regenerative medicine at Texas A&M University in College Station, has shown that MSC-derived exosomes could mitigate the damage from prolonged epileptic seizures in rodents⁴. According to Shetty, when exosomes are delivered nasally they permeate the animals’ entire forebrain within six hours. “We found that we could rescue cognitive function and also prevent abnormal neurogenesis in the brain,” he says. And, as in GVHD, the exosomes also seemed capable of modulating inflammation.

In their investigations of stroke and traumatic brain injury, Chopp and colleagues have found that exosome treatments in animals spur regeneration and remodelling of neural tissue^{5,6}. “You’ll find this whole restorative tapestry occurring throughout the central nervous system,” he says. “We can actually restore neurologic, motor and cognitive function.” Similarly, Marbán’s group has tested cardiac stem cells and their exosomes as a treatment for people with Duchenne muscular dystrophy, to prevent the heart damage that is a major cause of death for those with the disease. Not only did both the stem cell and exosome treatments protect heart function⁷, but they also promoted muscle repair throughout the bodies of treated mice. “The skeletal muscles from the leg were working more forcefully in animals that received the treatments in the heart,” says Marbán. “It seems entirely consistent with the idea that systemic effects of exosomes are responsible for the benefits from the stem cells.”

“We found that we could rescue cognitive function and also prevent abnormal neurogenesis in the brain.”

Exosomes might be able to deliver the therapeutic benefits of stem cells without the baggage that has impeded the latter’s translation into the clinic. Exosomes cannot self-replicate or form tumours. In addition, they are small enough for filtration to produce sterile material for use in patients, and stable enough for long-term freezer storage. Current data also suggest that the vesicles are remarkably safe. “We can use 10 or 20 times the therapeutic dose without seeing an adverse reaction,” says Lim, referring to the number of exosomes required to deliver a clinical benefit.

Despite the many therapeutic benefits that

have now been attributed to exosomes derived from MSCs, the mechanisms behind these effects remain frustratingly opaque. Exosomes seem to influence multiple components of the immune system, but to understand how they do this, researchers must carefully comb through their molecular cargo holds. Much of the focus so far has been on microRNA – short strands of RNA that encode no proteins themselves, but can modulate the amount of protein produced by other genes. Bioinformatic analysis of the material found within exosomes can help to identify strands of microRNA that act on disease-relevant cellular pathways. For example, Marbán found that one particular microRNA, miR-181b, accounts for many of the therapeutic effects of exosomes derived from cardiac stem cells⁸.

Some researchers are seeking to manipulate MSC-derived exosomes to carry not just naturally occurring microRNAs, but also synthetic RNA drugs. Raghu Kalluri, a cancer biologist at the University of Texas MD Anderson Cancer Center in Houston, has extensively studied the natural role of exosomes in driving and impeding the progression and spread of tumours. Now, he is repurposing these vesicles to deliver engineered RNA molecules that selectively shut off genes that drive cancer growth. “We had a mouse which had pancreatic tumours, and those tumours were accumulating high numbers of exosomes, so we asked: what can we deliver there?” he says. They opted for a therapeutic RNA molecule that inactivates a gene called *KRAS*, a well-known driver of pancreatic cancer⁹. “We found dramatic responses,” says Kalluri. “The tumours were smaller, and the mice lived significantly longer.” His team is now looking to apply a similar strategy to glioma – another hard-to-treat tumour.

Unclassified information

Some controversy surrounds the therapeutic contributions of microRNA relative to other biomolecules carried in exosomes. Marbán has found that RNA-depleting chemical treatments eliminate many of the therapeutic effects of his exosomes, but he notes that microRNAs represent just a portion of the poorly understood RNA molecules in these particles, and that non-microRNA species could have a yet-underappreciated beneficial role. “There’s a lot of things in there we don’t even know how to classify,” he says. Lim, in particular, has called the microRNA-centric model of exosome function into question¹⁰, on the basis of initial evidence that proteins might exhibit more potent biological activity in therapeutic exosomes than does RNA. She carefully profiled the molecular inventories of various

outlook

MSC exosome preparations, and concluded that “there was just not enough RNA to see an effect – most microRNAs are present at only about one copy per exosome”. Because exosomes also contain many enzymes that can greatly accelerate biological processes with just a few molecules, she thinks these could exert a more rapid and direct therapeutic effect than microRNA.

Giebel, too, is receptive to a more protein-oriented perspective. He points to several factors that could confound efforts to experimentally link an individual microRNA to an exosome’s effects. For example, manipulations that knock out a microRNA gene in MSCs might also disrupt the function of those stem cells and perturb their exosome output to an extent that far surpasses just the loss of that single microRNA as a cargo molecule. But Giebel also hesitates to write off entirely the contributions of RNA relative to proteins and other molecules. “Very likely the truth is in the middle,” he says.

Signal versus noise

Efforts to clarify these therapeutic mechanisms are further confounded by the considerable heterogeneity in exosome preparations. The term ‘exosome’ refers to a highly specific subset of extracellular vesicles, which are produced by a particular cellular pathway and exhibit diameters spanning roughly 30–150 nanometres. But this may be a misleading name for the preparations now being tested preclinically, which often contain a variety of non-exosomal vesicles. “Nobody should claim that they have achieved a 100% pure preparation,” says Gimona.

Further variability between preparations can arise in a number of ways. Several studies have established that different types of stem cell – and mature cells, for that matter – produce cell-specific pools of vesicles with distinct contents. Some researchers are looking to exploit this therapeutically; for example, Shetty’s lab has found evidence that vesicles from neural stem cells promote more-efficient neuronal repair than those from MSCs. But even different cultures of the same cell type may yield vesicles with different functional properties. “You can take the same MSC, raise it in different labs and it will behave differently,” says Lim. These differences become yet more noticeable with MSCs from donors who differ in age, sex and other biological factors.

Organizations such as the International Society for Extracellular Vesicles are developing best practices for producing and characterizing exosome preparations for clinical research. The key objectives are ensuring that vesicle isolates are free from harmful contaminants and have a

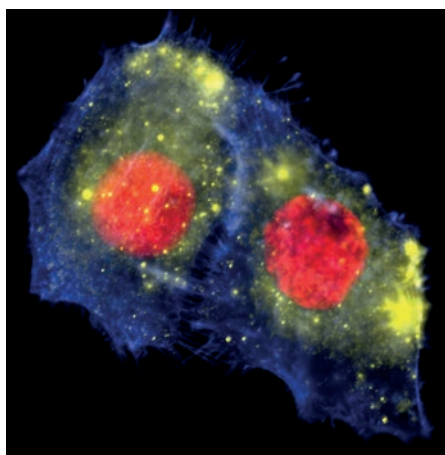

Exosomes (yellow) in cancer cells.

consistent set of functional properties. “If you want to treat a certain indication, you have to lay out how you think this would work,” says Eva Rohde, a cell-therapy researcher at the Paracelsus Medical University. “We are looking for predictive assays.” This can be complicated, given the myriad modes of action that vesicle preparations can exhibit; for example, Giebel notes that studies investigating exosomal treatments of GVHD would need to validate both their immunosuppressive activity and their capacity to promote repair in damaged tissues. But, by the same token, he thinks that clearing these hurdles should be sufficient to enable clinical testing even if the mechanism of action remains unclear. “If it has comparable activity to stem cells and is not harming the patient but reduces their symptoms, I’m good,” says Giebel.

“If it has comparable activity to stem cells and is reducing the patient’s symptoms, I’m good.”

The processes required to produce uniform preparations of exosomes suitable for clinical testing are expensive. As a result, only a handful of academic centres are currently able to pursue human trials. Gimona and Rohde are working at their institution’s clinical-grade manufacturing facility to optimize the medium- to large-scale production of trial-ready MSC exosomes. And Kalluri’s team has garnered enough funding from MD Anderson and philanthropic groups to support the launch of a phase I clinical trial of exosome therapy for pancreatic cancer, which began accruing patients this March. But most clinical development is now occurring under the aegis of industry. For example, Capricor Therapeutics in Beverly Hills, California, is

preparing to embark on a clinical trial based on Marbán’s work with exosomes as a treatment for muscular dystrophy.

Unfortunately, disreputable commercial clinics are cashing in on the hype, peddling unproven “cures” for numerous conditions, based on exosome preparations of questionable provenance. “These exosome mills are sprouting up all over,” says Chopp. Exosomes are much easier and cheaper to generate and handle than stem cells, and have fewer immediate safety concerns than cell therapies, he explains. And that makes them an appealing alternative for unscrupulous medical practitioners looking for an easy profit. And the steady trickle of exciting progress in pre-clinical research provides ready fodder for marketing. “I even get some of my papers cited in their brochures,” says Lim. These unregulated clinics routinely make claims that go well beyond the available preclinical data, and sometimes border on the outlandish. Indeed, a New Jersey-based clinician and Kimera Labs, an exosome producer in Miramar, Florida, ran foul of the US Food and Drug Administration (FDA) in April 2020 for offering exosomes that they said could prevent or treat COVID-19 – claims that have since been struck from the company’s website.

But, as with any therapy, a badly prepared batch of exosomes can pose an immediate threat. In December 2019, the FDA issued a public-safety warning about unregulated exosome clinics. The warning was based on reports of patients in Nebraska who developed sepsis after undergoing treatment. And although properly prepared exosomes have an excellent safety record, it will take a lot more testing, with careful clinical oversight, to identify any long-term risks. For example, Giebel notes that the same immune tolerance that keeps inflammation at bay and allows tissue to heal, could theoretically enable early-stage tumours to flourish and progress. “I think extracellular vesicles will be great therapeutic agents for many diseases,” he says. “But if somebody is using them in a bad way, it could kill the field for many years.”

Michael Eisenstein is a freelance science journalist in Philadelphia, Pennsylvania.

1. Chen, T. S. *Nucleic Acids Res.* **38**, 215–224 (2010).
2. Ibrahim, A. G.-E., Cheng, K. & Marbán, E. *Stem Cell Rep.* **2**, 606–619 (2014).
3. Kordelas, L. et al. *Leukemia* **28**, 970–973 (2014).
4. Kodali, M. et al. *Int. J. Mol. Sci.* **21**, 181 (2020).
5. Williams, A. M. *J. Neurotrauma* **36**, 54–60 (2019).
6. Xin, H. J. *Cerebr. Blood. F. Met.* **33**, 1711–1715 (2013).
7. Rogers, R. et al. *JCI Insight* **4**, e125754 (2019).
8. De Couto, G. *Circulation* **136**, 200–214 (2017).
9. Kamerkar, S. et al. *Nature* **546**, 498–503 (2017).
10. Toh, W. S., Lai, R. C., Zhang, B., & Lim, S. K. *Biochem. Soc. Trans.* **46**, 843–853 (2018).

Planting the seed of RNA crosstalk

Studies hinting that plants and fungi exchange RNA through extracellular vesicles are inspiring scientists to develop ways to protect crops. **By Roxanne Khamsi**

B iologists studying extracellular RNA (exRNA) – and the tiny spherical structures known as exosomes that shuttle this genetic information from cell to cell – typically focus on mammals. As long ago as the 1960s, however, scientists found that plant cells also generate vesicles that carry cargo out of the cell membrane. But for decades, these botanical observations were largely forgotten.

Plant biologist Hailing Jin at the University of California, Riverside, is trying to revive the field to work out how plants send cellular messages. She has found evidence that plants do this, in part, to thwart their fungal enemies. She is now designing fungicides that are based on exRNA.

Her team has engineered tomato plants to release exRNA that can silence the genes of the fungus *Botrytis cinerea*¹, which causes the grey mould disease that destroys millions of fruit, vegetable and flower plants every year. “The plants are much healthier” than those that lack this special twist, Jin says. When sprayed with the fungus, the leaves of engineered plants remain green and vibrant, whereas their normal counterparts develop splotchy leaves that are darkened and dying.

In 2013, her group found evidence that exosomes facilitate ‘crosstalk’ between plants and fungi². The researchers suggested that *B. cinerea* releases small RNAs that silence immunity genes in the model organism *Arabidopsis thaliana*. “Her 2013 paper was a real landmark,” says Roger Innes, a biologist at Indiana University in Bloomington. “It opened up whole new directions in plant science.”

Jin’s lab has since shown that *Arabidopsis* cells release extracellular vesicles that deliver RNA into *B. cinerea*, and that this RNA silences genes that are important in the fungus’s ability to infect plants³. And in a paper posted on the preprint server bioRxiv⁴, biologists reported that altering *Arabidopsis* so that the plants release exRNA offers some protection against a type of pathogenic bacteria. These results, which have not been peer reviewed, are “really shocking”, Innes says. “Bacteria don’t have a

classic RNA-interference pathway – so it has to be incorporated into some novel pathway that’s leading to gene silencing in bacteria.”

Jin says that although some scientists are continuing to genetically modify vegetables and fruits to fight destructive fungi and bacteria with exRNA, the lengthy and expensive regulatory process for genetically modified food means her team is pursuing a different approach. It is instead designing antifungal crop sprays that contain the silencing RNA.



Grey mould affects fruits such as strawberries.

Other scientists have taken inspiration from the exRNA communication seen in plants to design human therapies. Huang-Ge Zhang, an immunologist at the University of Louisville School of Medicine in Kentucky, is trying to mimic the RNA-shuttling vesicles found in plants by extracting and repurposing cellular components of fruits and vegetables. He has shown that grapefruit juice contains lipids – molecules that make up much of the membrane of cells and exosomes – that can be assembled into small shells that he calls “exosome-like nanovectors”⁵. Zhang and his colleagues loaded these nanovectors with anti-cancer drugs and gave them to mice with tumours. They found that mice that received this form of therapy lived for an average of 42.5 days, whereas mice treated with either

empty nanovectors or with the chemotherapy agent on its own lived for 20–30 days. Zhang says that one of the advantages of encapsulating drugs in this way is that the foods from which they are derived are non-toxic and cheap.

Zhang has received more than US\$1 million from the US National Institutes of Health for his work. He is currently collaborating with researchers at Louisville’s James Graham Brown Cancer Center on a clinical trial to test the use of plant-derived vectors to deliver curcumin – a component of the spice turmeric – to treat colorectal cancer. Zhang is also exploring whether ginger-derived vectors can be loaded with RNA-based therapeutics. His projects have attracted some commercial interest. Other groups are also exploring whether plant-derived nanovesicles can be used to deliver cancer therapeutics.

Some scientists say, however, that Zhang’s drug-shuttling structures can’t be called exosome-like. They point out that even though the structures are roughly the same size as exosomes, and are built with lipid molecules, that doesn’t mean the structures behave in the same way. It’s not just their size that makes exosomes special, says Clotilde Théry, who studies exosome biology at the Curie Institute in Paris. “Many extracellular vesicles or particles other than exosomes can display the same range of size,” Théry explains, but they don’t necessarily behave like exosomes. It is unclear, for example, whether the nanovectors can transmit payloads to cells in the same way as some exosomes do. And the human immune system might thwart plant-derived nanovectors, rendering them useless.

Innes, for his part, is looking for more evidence that exosomes are indeed involved in RNA signalling. Circular cross-sections can be seen near plant cells under a microscope, but Innes wants to confirm that these shapes are exosome spheres, and not just cylindrical tubes. To do this, his group is creating ultra-thin slices of plant cells and capturing an image of each slice with an electron microscope. It can then digitally recreate the 3D shape of the tiny structures assumed to be exosomes. He’s sure that plants do send out RNA signals, but he wants to definitively show the form of the structures that shuttle this genetic information. “We know it works,” Innes says. “The big question right now is how.”

Roxanne Khamsi is a freelance science journalist in Montreal, Canada.

1. Wang, M. *et al. Nature Plants* **2**, 16151 (2016).
2. Weiberg, A. *et al. Science* **342**, 118–123 (2013).
3. Cai, Q. *et al. Science* **360**, 1126–1129 (2018).
4. Singla-Rastogi, M. *et al. Preprint at bioRxiv* <https://doi.org/10.1101/863902> (2019).
5. Wang, Q. *et al. Nature Commun.* **4**, 1867 (2013).

Research round-up

Highlights from extracellular RNA studies. By Elizabeth Svoboda

Immune RNA drives heart disease

Small fragments of RNA that break away from immune cells might set people on the path to cardiovascular disease.

Mast cells – immune cells produced in the bone marrow – are known to encourage the blood-vessel irritation and swelling that signal the onset of cardiovascular disease, but precisely how these cells initiate this inflammation has not been well understood. Now, a study led by researchers at Justus Liebig University in Giessen, Germany, has shown that fragments of RNA released by mast cells cause cellular changes that trigger inflammation.

Silvia Fischer and her colleagues grew mast cells from mouse bone marrow *in vitro*. They then treated the mast cells with chemicals that caused the cells to release RNA-containing particles called exosomes – a release that happens naturally inside the body. When the team added the RNA-filled vesicles to a culture of cells that line blood vessels, the cells expressed more inflammatory proteins called cytokines. The higher the concentration of RNA-containing vesicles that were introduced, the more cytokines the cells expressed.

The results suggest that extracellular RNA from mast cells spurs the inflammation that degrades vascular health. Circulating RNA molecules might also be involved in changes to blood-vessel walls

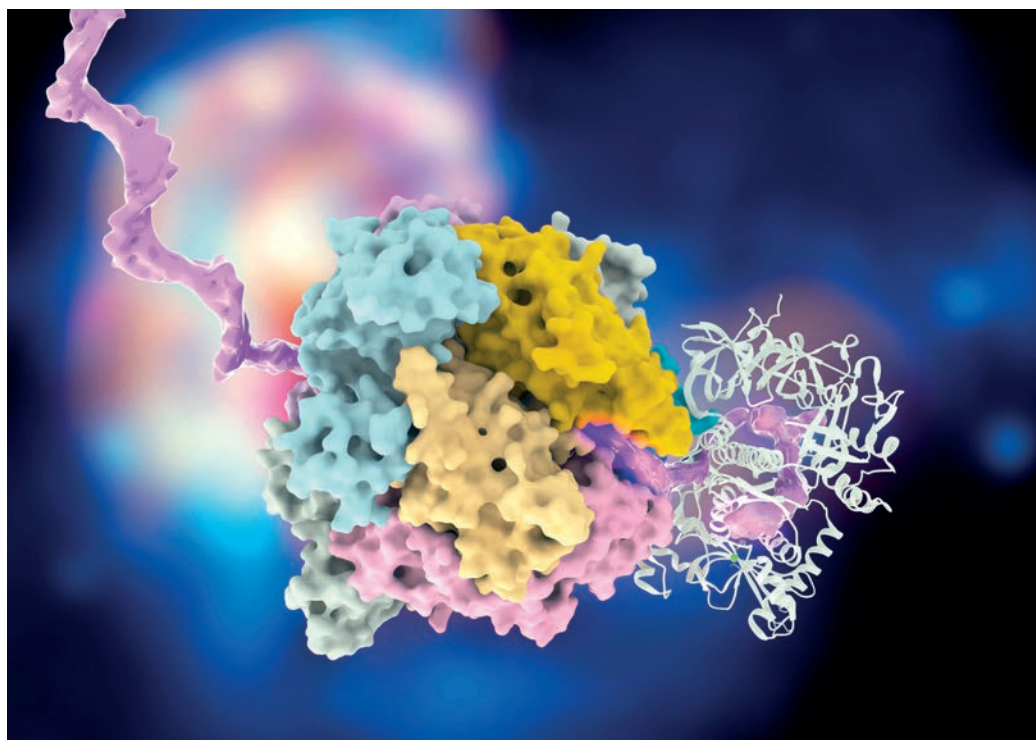

Molecular model of an exosome complex.

related to conditions such as high blood pressure, hardening of the arteries and aneurysm, in which blood-vessel walls balloon outwards. The team is continuing to study how extracellular RNA interacts with blood vessels, and hopes to find out whether the RNA from mast cells promotes cell signalling that might affect disease processes.

FASEB J. **33**, 5457–5467 (2019)

Biomarkers for anxiety disorder

Biological markers for post-traumatic stress disorder (PTSD) have mostly proved elusive. Kai Wang at the Institute for Systems Biology in Seattle, Washington, and her colleagues are shifting the picture by showing that levels of some RNA fragments circulating in

the blood of combat veterans with PTSD are different from the levels of those without the condition – a finding that could lead to a blood test for PTSD.

The researchers recruited 22 male combat veterans who served in Iraq or Afghanistan and an equal number of people without PTSD. They took a blood sample from each participant, extracted the fluid plasma portion and then sequenced the extracellular RNA found in the plasma. Compared with the control group, people with PTSD had unusual concentrations (sometimes higher than the control group, sometimes lower) of several RNA molecules circulating in their blood. These RNAs are involved in central nervous system development, inflammation and the control of the brain's neurotransmitter system. The team found a similar profile of circulating

RNA in a validation group of ten additional veterans with PTSD.

The authors hope to confirm their proposed biomarkers in a larger experimental group that includes both men and women. If a biomarker test for PTSD proves reliable across the board, psychiatrists could also adopt it as a tool to monitor treatment effectiveness.

J. Clin. Med. **8**, 963 (2019)

Revealing early-stage Alzheimer's disease

RNA fragments in the bloodstream could allow physicians to detect Alzheimer's disease at an early stage, when treatments are more likely to be effective.

Many people experience years of cognitive decline before learning that they have

Alzheimer's. Other methods for detecting the disease early, such as brain imaging and cerebrospinal fluid analysis, are too expensive or invasive for use in widespread screening programmes. The experimental test developed by José Rodríguez-Álvarez at the Autonomous University of Barcelona in Spain and colleagues relies instead on a blood sample. The test detects snippets of circulating RNA that control proteins involved in forming synapses, the crucial connections between brain cells.

When the researchers ran the blood test on more than 100 people with a wide variation in cognitive performance, they identified three RNA molecules that were present at high levels in people with mild cognitive impairment (MCI) and early Alzheimer's disease, but not in people with healthy cognitive function. People with MCI who went on to develop Alzheimer's had higher levels of these three RNAs than had people who did not progress to Alzheimer's.

The researchers are planning large-scale trials of their blood test to validate their findings. If it proves to be a reliable indicator of cognitive impairment, the test could form the basis of population-wide screening programmes, because it can be performed easily at a lab or a physician's office. Clinicians could also use the test to predict who is most likely to develop Alzheimer's.

Alzheimers Res. Ther. **11**, 46 (2019)

RNA boost for kidney regeneration

Some stem cells emit tiny particles containing fragments of RNA that help damaged kidneys to regrow. Giovanni Camussi at the University of Torino in Italy and colleagues report that enriching these particles – known as

extracellular vesicles, or EVs – with RNA molecules can elicit more-potent kidney regrowth than can non-engineered vesicles. This enrichment could allow for the development of drugs that use fewer EVs, potentially minimizing the drugs' risk and cost.

The team tested its approach on a group of mice with acute kidney injuries. Some of the mice were treated with naturally occurring EVs from mesenchymal stromal cells – a cell type known to regenerate injured tissue. Others received EVs from these stem cells that were treated with an electrical stimulus to open pores to pack more RNA molecules inside. The researchers enriched these vesicles with carefully selected RNA molecules that help cells in kidney ducts to grow more quickly.

A low dose of vesicles with the electrically added RNA cargo proved more effective at improving the mice's kidney function than did a similar dose of naturally occurring vesicles. Mice that received this dose of modified vesicles had less kidney damage, and their kidneys filtered toxins from the blood more efficiently. (Mice that received high doses of electrically treated EVs did not have significantly different outcomes from mice given high doses of untreated EVs.)

The study shows that vesicles can be made more therapeutically active by packing in a greater number of RNA molecules – a strategy that might spark the development of low-dose regenerative drugs for people with kidney injuries.

Int. J. Mol. Sci. **20**, 2381 (2019)

Predicting the course of multiple myeloma

The progression of multiple myeloma, a bone-marrow cancer typically affecting people over the age of 60, varies greatly from

one person to the next. Andrew Spencer at Monash University in Melbourne, Australia, and colleagues report that levels of various RNA molecules in the bloodstream reveal key features of individual cases of the disease – an approach that could allow physicians to more accurately track patients' progress and to assess prognoses.

The researchers observed how 24 people with multiple myeloma that had returned or was resistant to treatment responded to a 28-day cycle of chemotherapy. They took blood samples from each participant several times over the course of the month and sequenced genetic information, including extracellular RNA, from each sample.

Participants with high levels of *CRBN* circulating RNA at the start proved to have a higher-than-normal risk of fast disease progression. Later in the month, people with increased blood levels of *IKZF1* RNA molecules, showed a better response to therapy and higher survival rates than did those with lower levels of this molecule. People with low levels of *CRBN* RNA at the outset and high levels of *IKZF1* RNA later responded the best.

The team plans to test a larger group of people with multiple myeloma to see if these circulating RNAs prove useful as biomarkers in a broader population. If so, its goal – a blood test that can be used to monitor each case and predict disease course with pinpoint precision – would move closer to clinical reality.

Leukemia **33**, 2022–2033 (2019)

Molecular 'backbone' increases efficiency

Extracellular RNA shows promise in correcting abnormal cell processes in conditions such as heart disease, cancer and brain injury. However, high

doses of some circulating RNAs can be toxic – a roadblock that has ended some clinical trials. Derrick Gibbins at the University of Ottawa and colleagues have worked out a way to pack RNA molecules into a 'backbone' configuration that ensures more of the molecules affect target organs. This greatly reduces the amount of RNA needed for treatment and could lower the health risks.

The team made therapeutic sequences of RNA inside the nuclei of cells. Using enzymes, it integrated these sequences into an additional segment of RNA known as a backbone. This composite backbone then appeared in vesicles that the cells produced. The researchers injected the vesicles into mice and showed that they were widely distributed to organs, including the kidney, liver, intestine and lungs.

Importantly, a high percentage of the RNA molecules in the custom vesicles accumulated in target organs without being destroyed by the surrounding cells. By contrast, when the RNAs were delivered using lipid nanoparticles – a more established delivery technique – or with vesicles that lacked backbones, far fewer of the molecules reached their target. The custom vesicles probably perform best because of the efficient way that RNA is packaged.

The researchers say that their proof-of-concept study justifies further development of the backbone approach to see whether it is practical for safe drug delivery in clinical trials.

Nature Biomed. Eng. **4**, 52–68 (2020)



For the latest research published by Nature visit: <http://go.nature.com/2xyawlx>

outlook



Picture a Scientist

by Sharon Shattuck and Ian Cheney.
Visit pictureascientist.com for screenings.
In limited release, starting June 12, 2020



BIOLOGIST Nancy Hopkins organized a cohort of women at M.I.T. to bring attention to gender imbalance in the science departments there during the 1990s. Her story is featured in the film.

Overt sexual advances are just one form of harassment against women in the sciences; the bulk of offenses are made up of quiet acts of discrimination and bullying that accumulate over time. This essential documentary by filmmakers Shattuck and Cheney gives disturbing first-person accounts of such abuse and mistreatment by prominent male researchers—from the rocky fields of Antarctica to the genetic laboratories of Harvard—and offers a powerful contribution to the larger conversation about inherent bias, unseen prejudice and personal accountability. The film uniquely captures the emotion of the battle that women in science—especially women of color—have had to wage simply to do the work they love. It is a stark reminder that although some progress has been made, equal representation—and treatment—in research science has a long way to go.

The End of the River: Why the Long Struggle to Hold Back the Mississippi May Soon Be Lost, Wreaking Trillion-Dollar Chaos across the American South
by Simon Winchester. Scribd Originals, 2020

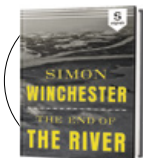

(by subscription)

In the early 1800s people began straightening the Mississippi River to make it more navigable and to control flooding. Now, in a stretch at the border of Louisiana and Mississippi, the water, inclined to follow the easiest path to the sea, is straining to jump over its human-made channel and into the neighboring Atchafalaya Basin. If it does, the downstream remnant passage of the Mississippi will stagnate, disrupting ports and city water sources. In this slim volume, writer Winchester describes how human hubris caused this predicament, as he explores the engineering feats that are struggling to keep the river in place. The situation, he writes, has turned the waterway into “the nation’s Achilles’ heel.” —*Andrea Thompson*

Six Days in August: The Story of Stockholm Syndrome
by David King. W. W. Norton, 2020 (\$26.95)



American historian and author King shares remarkable on-the-ground details of the famed Norrmalmstorg robbery of 1973 in this smart cross between a true-crime thriller and a psychological investigation. During the nearly weeklong ordeal, Jan-Erik Olsson held four people hostage in a Stockholm bank and demanded his friend, career criminal Clark Olofsson, be released from prison and brought to the scene. In the event’s aftermath, the hostages reported surprisingly fond feelings for their captors, inspiring the term “Stockholm syndrome.” Use of the expression is still widely popular, although little research exists. Some suggest it confuses hostage allegiance to a captor with the desperate need to survive. Others allege that because the incident involved three women hostages, misogynist biases led psychologists to label these victims with an illness.

The End of Everything (Astrophysically Speaking)
by Katie Mack. Scribner, 2020 (\$26)



The cosmos might end by drifting into uniform chaos. Or the finale could involve an expanding bubble universe with new laws of physics. The very space between galaxies, stars, planets and atoms may even spread so much that it rips everything apart from within. If the world’s current troubles weren’t worrying enough, astrophysicist Mack offers a whirlwind tour of our possible demises and what investigating the options can reveal about physics. Through informal but rigorous prose, she describes the weird wrinkles and implications of these potential endings—for instance, how expansion makes the most distant galaxies actually look larger or how quantum changes could prompt new physical laws—and what they would look like from our only vantage point. —*Sarah Lewin Frasier*

EBOOKS

SCIENTIFIC
AMERICAN®

Secrets OF THE Brain



The Hidden Mind

Much of our brain activity occurs below our conscious awareness. In this eBook, we look at various behind-the-scenes ways the brain works to keep us healthy and process information, including immunity, navigation and intuition.

sciam.com/ebooks

SCIENTIFIC
AMERICAN. eBooks

Scientific American is a registered trademark of Springer Nature America, Inc.

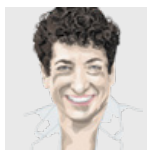

Naomi Oreskes is a professor of the history of science at Harvard University. She is author of *Why Trust Science?* (Princeton University Press, 2019) and co-author of *Discerning Experts* (University of Chicago, 2019).

The False Logic of Science Denial

Arguments against the reality of COVID-19 mirror those against climate change and evolution

By Naomi Oreskes

In college, I learned about the myriad logical fallacies that pervade our world. Good logic, it turned out, was pretty restrictive. It consisted primarily of *modus ponens*—“If A is true, then B is true. A is true. Therefore, B is true”—and *modus tollens*—“If A is true, then B is true. B is not true. Therefore, A is not true.”

In contrast, there is a universe of logical fallacies. In science, the most vexing typically takes the following form: My theory says: if P, then Q. I design an experiment to see if Q obtains. It does. Therefore, P is true. Sadly, this conclusion is logically incorrect. Q might hold for a variety of reasons having little or nothing to do with my theory. Yet scientists make this mistake all the time, which led philosopher Karl Popper to argue that the method of science is—or at least should be—falsification. Popper insisted that one can never prove that a theory is true, because that would require you to test it in every conceivable circumstance, which is impossible. But just a single counterexample can prove a theory false.

While Popper’s theory was profoundly counterintuitive, many scientists were attracted to it for its clarity and (apparent) logical



Illustration by Jay Bendt

rigor. Yet there is a logical flaw here, too. My experiment could have failed for reasons having nothing to do with the theory itself. My experimental setup, for example, might have been insufficiently sensitive to detect the predicted effect. This problem has no logical resolution, but scientists grapple with it mostly through concision (asking which explanation is most consistent with evidence from a variety of sources) or inference to the best explanation (looking at a problem from a variety of angles and seeing which explanations hold up best).

All this is to say that logical fallacies are everywhere and not always easily refuted. Truth, at least in science, is not self-evident. And this helps to explain why science denial is easy to generate and hard to slay. Today we live in a world where science denial, about everything from climate change to COVID-19, is rampant, informed by fallacies of all kinds. John Cook of George Mason University has, for example, undertaken an analysis of the logical fallacies and distortions tied to climate change denial, which include jumping to conclusions, cherry-picking data, raising impossible expectations, relying on fake experts, encouraging conspiracy theories and questioning the motivation of scientists. But there is a meta-fallacy—an über-fallacy if you will—that motivates these other, specific fallacies. It also explains why so many of the same people who reject the scientific evidence of anthropogenic climate change also question the evidence related to COVID-19.

Given how common it is, it is remarkable that philosophers have failed to give it a formal name. But I think we can view it as a variety of what sociologists call *implicatory denial*. I interpret implicatory denial as taking this form: If P, then Q. But I don’t like Q! Therefore, P must be wrong. This is the logic (or illogic) that underlies most science rejection.

Climate change: I reject the suggestion that the “magic of the market” has failed and that we need government intervention to remedy the market failure. *Evolutionary theory:* I am offended by the suggestion that life is random and meaningless and that there is no God. *COVID-19:* I resent staying home, losing income or being told by the government what to do.

In many cases, these objections are based on misunderstandings; evolutionary theory does *not* prove the nonexistence of God. In others, the implications are real enough. Climate change *is* a market failure, which will take government action to address. And absent a system for widespread testing and contact tracing, there was no known way to slow the spread of SARS-CoV-2 in the U.S. without the majority of us staying home. COVID-19 has shown how dangerous the fallacy of implicatory denial is. When we reject evidence because we do not like what it implies, we put ourselves at risk.

The U.S. could have acted more quickly to contain COVID-19. If we had, we would have saved both lives and jobs. But facts have an inconvenient habit of getting in the way of our desires. Sooner or later, denial crashes on the rocks of reality. The only question is whether it crashes before or after we get out of the way. ■

JOIN THE CONVERSATION ONLINE

Visit *Scientific American* on Facebook and Twitter or send a letter to the editor: editors@sciam.com



Steve Mirsky has been writing the Anti Gravity column since a typical tectonic plate was about 36 inches from its current location. He also hosts the *Scientific American* podcast Science Talk.



Hand Out

The COVID-19 pandemic has revealed that we don't need handshakes

By Steve Mirsky

Here's something I thought I'd never say: Donald Trump was correct. Back in 1997, anyway. About shaking hands.

"The Japanese have it right," the allegedly germaphobic Trump wrote (with co-author Kate Bohner) in the book *Trump: The Art of the Comeback*. "They stand slightly apart and do a quick, formal and very beautiful bow in order to acknowledge each other's presence ... I wish we would develop a similar greeting custom in America. In fact, I've often thought of taking out a series of newspaper ads encouraging the abolishment of the handshake."

Of course, because of COVID-19, the handshake is out. Unfortunately, it could make its own comeback without vigorous lobbying against it. I will now do some of that lobbying.

"Recent medical reports," Trump also wrote, "have come out saying that colds and various other ailments are spread through the act of shaking hands. I have no doubt about this."

Indeed, a search using the terms "handshake" and "infection" in journal articles between 1990 and 1997 turns up a 1991 write-up in the *Journal of Clinical Microbiology* with the title "Potential Role of Hands in the Spread of Respiratory Viral Infections: Studies with Human Parainfluenza Virus 3 and Rhinovirus 14."

This piece is undoubtedly the one that Trump read in his comprehensive and careful research—it stood out as his likely source because most of the search results for that time period were for articles talking about the molecular "handshake" between an HIV protein and human cells. Such studies might only have brought him unpleasant reminders that led him on the *Howard Stern Show* to compare his risk of STDs to fighting in Vietnam.

In another piece I turned up, published in the journal *Medical Record*, Nathan Breiter wrote about running into a friend and automatically shaking hands, only to find the hand "rough and oily." Breiter later learned that what he felt was syphilide: a skin lesion caused by syphilis. This experience got Breiter, as a trained physician, to thinking.

After considering how handshakes happened—"the custom of shaking hands originated in the ancient and universal practice of grasping the weapon hand during a truce as a precaution against treachery"—Breiter suggests banishing the practice to the medical waste bin of history: "So we see that from a comparatively dark and illiterate period a custom having a rational origin, which rationale dwindled into nothingness during its spread and migration through successive centuries, was ushered into our glorious civilization, unnecessary in its essence, devoid of all intelligence, and positively injurious to public health."

As the florid writing gives away, this article appeared well before any of Trump's "recent medical reports." It's from 1897, exactly a century before *The Art of the Comeback*, so the antishake notion has been around for a while. By the way, the comeback book is a sequel to *Trump: The Art of the Deal* (ghostwritten by the now regretful Tony Schwartz). The second book was motivated by one of Trump's artful corporate bankruptcies.

Sadly, as president, Trump went from disdaining the handshake to weaponizing it. Videos with various world leaders depict him grabbing his counterpart's palm, yanking it—and them—closer and holding their hand hostage for a while. The move seems to be an attempt to physically dominate but makes it look like he heard only the first word in "bully pulpit."

We can do better. In addition to bowing, other nontouch greetings exist in many cultures. There's the Hindu palms-together and head bow; the Islamic hand on the heart; the military salute; the Vulcan split-hand gesture. (*Star Trek* star Leonard Nimoy based Spock's smooth move on a Hebrew blessing symbol. Go to a Jewish cemetery if you want to see plenty of graves adorned with what most people think of as Vulcan.)

I like any and all of the alternatives better than the traditional Western grope. The time has come to say, "Look. No hands." ■

JOIN THE CONVERSATION ONLINE

Visit *Scientific American* on Facebook and Twitter or send a letter to the editor: editors@sciam.com

AUGUST

1970 A Lunar "Tablespoonful"

"In the broad, flat lunar maria, or 'seas' (such as Mare Tranquillitatis, the site of the *Apollo 11* manned landing), the depths of craters that have reached bedrock indicate a regolith thickness of from five to 10 meters. Thus the *Apollo 11* astronauts Neil A. Armstrong and Edwin E. Aldrin, Jr., did not come within several meters of solid rock at Tranquillity Base, and the geology picks they had brought along for the purpose of chipping specimens off outcrops were superfluous. They stood and walked on top of the regolith, and the lunar sample they returned was collected, with scoop and tongs, from this layer of rock debris. Our own group at the Smithsonian Institution Astrophysical Observatory has been working with 16 grams (about a tablespoonful) of the soil. —John A. Wood"



1970: Footprint of one of the *Apollo 11* astronauts on the moon reveals the consistency of the lunar surface but also serves as a metaphor for human exploration of the galaxy.

many unkind things that have been said about the mango. Some of them have hardly more fiber in them than a freestone peach, and can be cut open lengthwise and eaten as easily with a spoon as a cantaloupe."

Schools and the Army

"The National Research Council announces that the mental tests which were used with striking success in the Army during the war are to be used on a large scale in



1970



1920

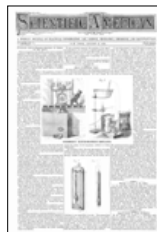

1870

American public schools. A program of group tests has been worked out which will make it possible to conduct wholesale surveys of schools annually, or even semi-annually, so that grade classification and individual educational treatment can be adjusted with desirable frequency."

1870 Of Toadstools and Whales

"It is a simple matter of fact and of every day observation that all forms of animal work are the result of the reception and assimilation of a few cubic feet of oxygen, a few ounces of water, of starch, of fat, and of flesh. In a chemical point of view man may be defined to be something of this sort. That great authority, Professor [Thomas] Huxley, has lately been discussing what he calls 'protoplasm, or 'the physical basis of life.' He seeks for that community of faculty which exists between the mossy, rock-incrusted lichen, and the painter or botanist that studies it. Professor Huxley has not proved, and it is impossible for him to prove, that these protoplasmic may not have essential points of difference. Physiologists cannot yet tell us how it is that 'of four cells absolutely identical in organic structure and composition, one will grow into Socrates, another into a toadstool, one into a cockchafer, another into a whale.'"

1920 The Mango Bears Fruit

"The U.S. Department of Agriculture has secured through its agricultural explorers and by exchange with the British East Indian departments of agriculture one of the largest collection of mango varieties in the world, and now has in fruit, at its plant introduction station at Miami, Fla., about 20 varieties. It is said that these selected varieties strikingly belie the

NASA (1); SCIENTIFIC AMERICAN, VOL. CXII, NO. 12; MARCH 20, 1915 (2)

EPIC TALES



Space Exploration

Planets and stars are as much a product of "nature's laboratory" as *Homo sapiens*. And while our species examines the information gleaned from the universe that surrounds us, we also have an emotional sense of wonder at revealing the secrets of nature and our place within it.

(This magazine may tend to leave emotion to neuroscience, as our focus is on scientific data—but we also publish poetry.) From the invention of the first telescope in 1608 to the discovery of the Milky Way galaxy's place in Laniakea—a great river of galaxies streaming toward a giant hidden gravity source—our exploration of the universe so far follows a trend: we explore with instruments and with our imaginations. And

1915: This cover imagined what the surface of Saturn's moon Titan would look like. Ninety years later the Huygens probe touched down on Titan and sent back images of the actual landscape.

one day we will go ourselves, leaving our footprints across the universe.

—D.S.



Nanjing School: Extracellular microRNA mediates co-evolution between species



AUTHORS

Chao Yan^{1,2}, Xi Chen^{1,2}, Chen-Yu Zhang^{1,2}

ADDRESS

¹Nanjing Drum Tower Hospital Center of Molecular Diagnostic and Therapy, Jiangsu Engineering Research Center for MicroRNA Biology and Biotechnology, NJU Advanced Institute of Life Sciences, State Key Laboratory of Pharmaceutical Biotechnology, School of Life Sciences, Nanjing University, Nanjing 210023, China;

²Institute of Artificial Intelligence Biomedicine, Nanjing University, Nanjing 210023, China.

In the past decade, a group of laboratories from the School of Life Sciences, Nanjing University (SLiS of NJU) led by microRNA (miRNA) researcher Dr Chen-Yu Zhang, have focused on research in the field of extracellular miRNA (Fig. 1). The group's original 2008 publication¹ on the stable existence of serum miRNA is one of the most cited papers published by Chinese scholars in the past century and is the foundation for all serum miRNA biomarker studies. The work on secreted miRNA has led to extracellular vesicle-based delivery of small interfering RNA (siRNA) therapy. This white paper describes research undertaken by groups at SLiS of NJU, which includes a suggestion that plant miRNA could enter human circulation and exert biological functions, a new theory relating to traditional Chinese medicine (TCM), and a genetically engineered lettuce that could provide a therapy for the hepatitis B virus. We also describe work at SLiS of NJU on plant miRNA in pollen that determines whether honeybee larvae develop into a queen or worker bees, therefore deciphering the mystery of the honeybee caste formation. The multidisciplinary group effort led

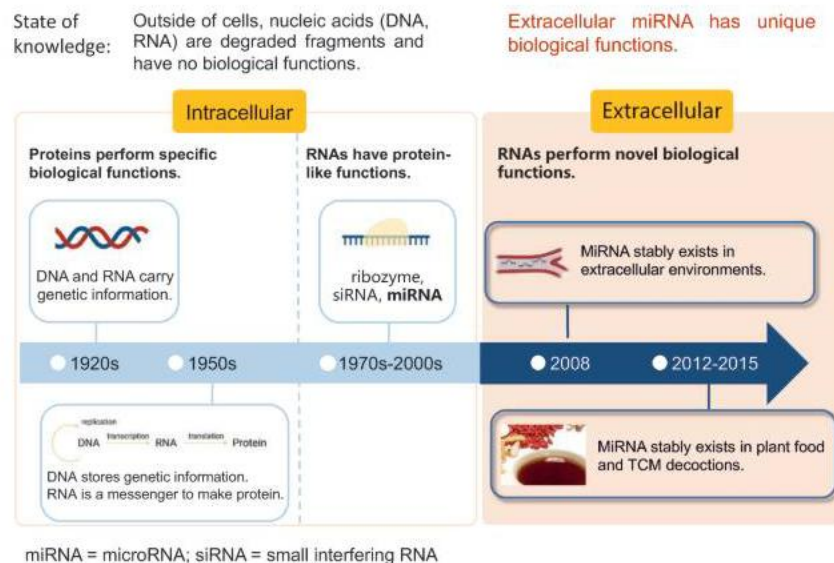

Figure 1. A three-stage history of nucleic acid study. DNA and RNA were known to carry genetic information but were thought to lack any further biological function. The discovery of ribozymes, small-interfering RNA and microRNA (miRNA) indicated that RNA can have protein-like functions, but it was still thought RNA was confined to the intracellular environment. In 2008, Dr Chen-Yu Zhang's group discovered stable extracellular miRNA in blood¹, and later also in plant food⁷ and TCM decoctions¹¹. These findings indicate that miRNAs have a biological function outside the cell.

to the theory that extracellular miRNA mediates the co-evolution between species.

SERUM MICRORNAS AS POTENTIAL BIOMARKERS

MiRNAs are a class of single-stranded, small non-coding RNAs involved in post-transcriptional gene regulation. In 2008, Chen-Yu Zhang's group demonstrated that serum miRNAs are stable in humans and animals¹. Using deep sequencing, the group

characterised the miRNA profile in human sera and identified unique patterns of serum miRNAs that distinguish patients with cancer and diabetes from healthy subjects. The findings suggest that the specific serum miRNA profiles may serve as fingerprints for disease diagnosis. In the same year, a separate study² identified plasma miRNAs as promising biomarkers for prostate cancer. The findings challenge the convention that

RNA is unstable in extracellular environments containing ribonucleases that degrade RNA. Building on other studies, accumulating evidence suggests that miRNAs circulate in a stable, cell-free form in extracellular biofluids including saliva, urine and breast milk and — because the extracellular miRNAs are tightly correlated with diseases such as cancers and diabetes — have potential to be diagnostic biomarkers³.

SECRETED MICRORNA: AUTOCRINE, PARACRINE OR ENDOCRINE?

The finding that extracellular miRNAs circulate in body fluids, despite the presence of ribonuclease, indicates that mechanisms exist to protect miRNAs from degradation. Work at SLIS of NJU looked into whether extracellular vesicles (EVs) could function as a barrier to shield miRNAs from degradation. EVs, including nanometre-size exosomes and submicron-size microvesicles, are membrane-enclosed vesicular compartments that transport proteins, lipids and miRNAs in the extracellular environment. Zhang's group found that the majority of circulating miRNAs were present in exosomes and microvesicles in human plasma rather than EV-free plasma⁴. The group proposed two models⁵ to explain the stability of extracellular miRNAs: (i) the protection of miRNAs by the membrane structures of EVs; and (ii) the stabilization of miRNAs by the formation of protein-miRNA complexes such as Argonaute 2. Moreover, they found that the miRNA profiles of EVs differ significantly from that of parent cells, and that cells selectively package different miRNAs into EVs when responding to different stimuli⁴. Therefore, the packaging or sorting of miRNAs into exosomes may be controlled by a specific mechanism. The secreted miRNAs can be delivered into recipient cells, where exogenous miRNAs silence the target genes and trigger downstream signalling events⁴. However, EV-encapsulated secreted miRNAs are not the only form of extracellular miRNAs. Extracellular miRNAs are generated through three main routes: (i) active secretion in EVs in an energy-dependent, selective process; (ii) release from donor cells in association with RNA-binding proteins; and (iii) passive leakage from broken or damaged cells owing to tissue injury, cell

Secreted microRNAs (miRNA) function like hormone/cytokine.

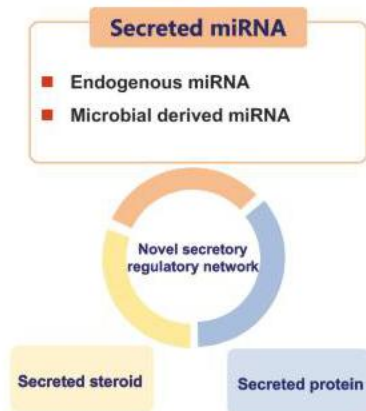

Abnormal secretion of miRNAs can cause diseases.

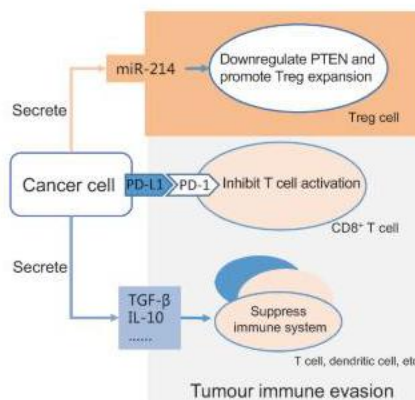

Figure 2. The microRNAs (miRNAs) secreted by endogenous cells circulate in body fluids and are delivered into recipient cells where they can silence the target genes and trigger downstream signalling events. Normal secretion of extracellular miRNAs maintains physiological homeostasis. Abnormal secretion can cause disease: for example, tumour cells can utilize two mechanisms to evade immune surveillance: (i) upregulation of don't find me signal on cell surface such as PD-L1 to evade the inspection by PD-1 on T cells; and (ii) direct modulation of the host immune cells by secretion of anti-inflammatory cytokines such as TGF-β and IL-10. Dr Chen-Yu Zhang's group provides the first evidence that tumour cells can actively modulate the host immune system via the secretion of miRNAs. Secreted miR-214 from tumour cells can promote the expansion of regulatory T cells (Tregs) and facilitate tumour immune escape through downregulation of PTEN in recipient CD4+ T cells⁵.

apoptosis or necrosis. It remains under debate whether EV-free miRNAs can be taken up by cells and participate in particular biological processes.

Work by Zhang's research group on secreted miRNA suggests a new mechanism of intercellular communication: miRNAs secreted by a cell can either bind to autocrine receptors of the same cell to induce a signal (autocrine), transmit a local signal between nearby cells (paracrine), or travel to distal cells to spread a signal (endocrine). Intercellular communications mediated by hormone-receptor and antigen-antibody take place between certain types of cell, using cell-surface receptors. Secreted miRNAs have the potential to influence every type of cell, to deliver many types of miRNAs with each miRNA targeting multiple genes to affect specific target cells. Research into the biological relevance of miRNAs has shown that abnormally secreted miRNAs can lead to dysfunction and disease⁶ (Fig. 2). Undoubtedly, the elucidation of this novel siRNA transfer system will herald a new

era in our understanding of signal transfer between cells.

PLANT MICRORNAS: WE ARE WHAT WE EAT

The focus of Zhang's research group turned to whether miRNAs could transfer between distantly related, complex organisms and, if so, whether miRNAs could facilitate cross-talk between species. On the basis that humans consume plant-based foods such as grains, vegetables and fruits every day, the group hypothesized that exogenous plant miRNAs could withstand the acidic environment in the stomach and the digestive enzymes in the gastrointestinal tract and enter tissues.

Gene sequencing can determine whether miRNA is of plant or animal origin. Zhang's bioinformatics group identified about 40 types of plant miRNAs after analysing serum RNA obtained from blood samples from healthy Chinese donors; some plant miRNAs were present at concentrations comparable to major endogenous human miRNAs⁷. Two plant miRNAs

with the highest concentrations, MIR156a and MIR168a, which have been reported in rice (*Oryza sativa*) and crucifers (*Brassicaceae*), were acquired through food intake⁷. Research demonstrated that MIR168a could bind to low-density lipoprotein receptor adapter protein 1 (LDLRAP1) miRNA, inhibit LDLRAP1 expression in mouse liver and consequently regulate low-density lipoprotein removal from plasma⁷. The study indicates a possible model of cross-kingdom miRNA transfer in which plant miRNAs can survive gastrointestinal digestion in mammals and when inside endogenous cells can elicit functions by regulating target genes and influencing physiological conditions.

'You are what you eat' is a proverbial saying in many countries. On the basis that foods confer health, Zhang's research group is studying the biological mechanisms behind the benefits that eating plants can bring to humans. Diverse plant foods may bear distinct information in the form of different miRNA type and concentration, thereby generating

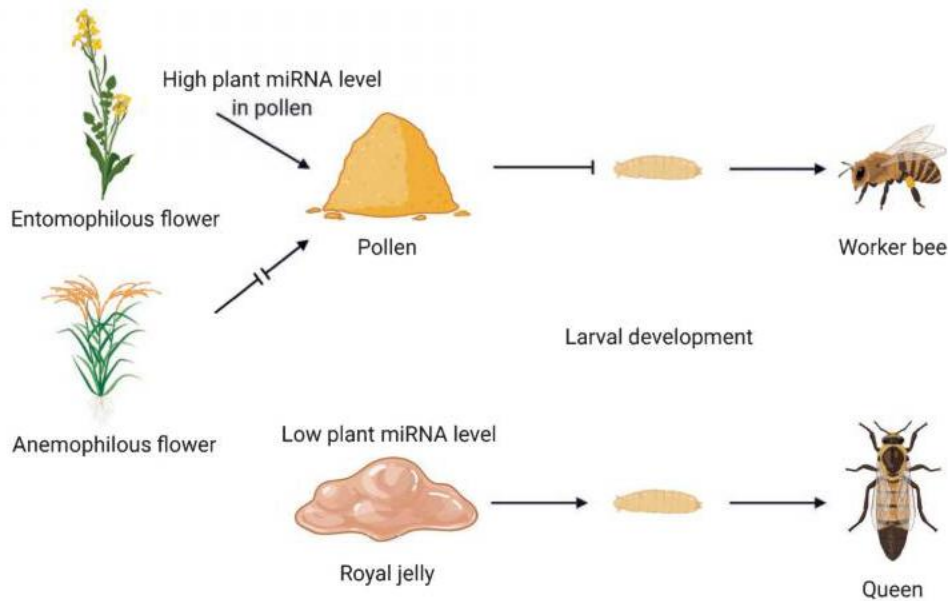

Figure 3. Entomophilous plants are insect-pollinated and contain microRNAs (miRNAs) that influence the size, morphology, colour and development of flowers and produce pollen that is attractive to insects including honeybees. Bee larvae that are fed pollen develop into worker bees because they receive a higher quantity of plant miRNAs than the larvae that receive only royal jelly⁹.

different forms of gene regulation patterns and physiological impact on consumers. Therefore, we are not only eating food, but also eating 'signals' and 'information'. By studying cross-kingdom miRNA transfer they hope to find out whether dietary miRNAs have nutritional value. Important nutrients in foods include carbohydrates, proteins, lipids, vitamins and minerals. Plant miRNAs may represent a previously uncharacterized but essential bioactive compound in food. For instance, because regular consumption of plants is recommended to lower the risk of cardiometabolic diseases, cancers and age-related functional disorders, Zhang's group asked whether dietary plant miRNA plays a part in preventing disease.

The existence of plant miRNAs in the tissues of animal models including pig, panda and rodent; the biological relevance of plant miRNAs in the prevention and treatment of human diseases have also been exhibited, including cardiovascular diseases, tumours, chronic inflammation and pulmonary fibrosis⁸. Cross-kingdom miRNA transfer may be a conserved and universal

phenomenon that involves many complex organisms. With the rapid development of this field, more cross-kingdom miRNAs will be discovered along with their biological effects. Future studies should explore how miRNAs move across the boundary of different kingdoms, i.e., how plant miRNAs pass through the gastrointestinal tract and are absorbed by mammalian cells.

CROSS-KINGDOM REGULATION AND MICRORNA, TO "BEE" OR NOT TO BE, THAT'S THE QUESTION

From an evolutionary point of view, cross-kingdom miRNA transfer holds a unique position in facilitating cross-talk, communication and signal spreading in distant species from different kingdoms. This mechanism may shed new light on our understanding of the evolution of many extant species and provide new insight into their interactions and inter-dependence. Xi Chen's group from SLIS of NJU sought to broaden their understanding of miRNA transfer between species and selected the honeybee (*Apis mellifera*) as a model organism to study. Female

honeybees live in a social system and are divided into two castes: queens and workers. Queens are reproductive, have a larger body size, develop faster and live for longer than worker bees. Worker bees are sterile and are destined for a lifetime of intensive tasks such as housekeeping and food collection. Honeybee larvae are genetically identical but the fate of the larvae depends upon their diet. Larvae fed a diet of rich royal jelly develop into queens, whereas larvae that eat a less refined diet of 'bee bread' and pollen develop into worker bees. Since bee bread and pollen are mainly plant-originated, while royal jelly is a glandular secretion of nurse bees, the diets for worker- and queen-destined larvae are differentially derived from plant and animal sources, respectively. Chen hypothesized that the origin of the RNA in larval diets may impact honeybee development. To test the hypothesis, Chen's research group measured miRNA levels in royal jelly, honey, bee bread and pollen and found that bee bread and pollen had much higher concentrations of plant miRNAs than did royal jelly⁹. The team suggests that supplementing

royal jelly with plant miRNAs from pollen is one factor that prevents larvae from becoming a queen. Mechanistic studies suggest that *Apis mellifera* TOR (*amTOR*), a stimulatory gene in caste differentiation, is inhibited, at least in part, by plant MIR162a, helping to prevent larval differentiation into queens and inducing development towards worker bee phenotype⁹. The study suggests a mechanism for honeybee caste formation and also a system in which extracellular miRNAs could be part of cross-kingdom regulation.

The reason why honeybees use such a sophisticated and intricate mechanism to regulate the queen-worker dimorphism is a puzzle. Because only one single reproductive female queen is allowed, the caste structure has to be tightly regulated. In Chen's theory, the reliance upon bee bread and pollen as the exclusive food for larvae destined to become sterile workers may have evolved in concert with the exploitation of plant miRNAs for caste regulation through a form of 'RNA interference (RNAi) castration'. Given that the effect of a larval diet that contains bee bread is to help maintain the stability of the colony's social order, it seems that plant miRNAs are not accidentally included in the larval diet but are collected with purpose, possibly to ensure the survival of the colony. The cross-kingdom regulatory function of plant miRNAs may have evolved with the selection of food sources by honeybees. Flowering plants have developed the characteristics that are attractive to honeybees for pollination, and the regulatory effects of plant miRNAs on caste differentiation in honeybees seems, at least in part, to influence the characteristics of the pollinators (**Fig. 3**). The selection of food sources by honeybees indicates an extraordinary evolutionary adaptation for colony success through partnership between two interacting organisms. Thus, honeybees and

flowering plants exert selective pressures on each other in a co-evolutionary relationship, thereby affecting each other's destiny in the inter-connected ecosystem.

Is this kind of 'borrowing' RNA substance from another species to regulate the process of their own survival and adaptation a common phenomenon? Considering that species have experienced millions of years of co-evolution to form the ecosystem we live in today, it is possible that cross-kingdom miRNA transfer may be frequently seen in nature. Indeed, emerging evidence has revealed that miRNAs can travel across the boundaries of species or kingdoms to spread gene silencing signals, thereby serving as a bond connecting the animal, plant and microbial kingdoms¹⁰. Such a phenomenon may make the study of miRNAs fundamental to shed light on the biological relevance of these molecules at an ecological and evolutionary scale.

MIRNA FROM HERBAL MEDICINE, PLANTS VS. ZOMBIES?

TCM, especially herbal medicine, has been used in China to treat and prevent disease for thousands of years. However, many of the theories and practices employed in TCM are scientifically unsubstantiated because they have not been rigorously tested in randomized, controlled clinical trials. Some researchers have attributed the effects of TCM to the content of secondary metabolites and small molecules; macromolecules, such as RNA, have not been considered. RNA is thought to be unstable in the gastrointestinal tract and, because TCM herbs are usually boiled in water for several hours to produce a decoction, the assumption is that RNA is degraded during the preparation process. Consequently, scientific research on TCM decoctions often excludes RNAs from the biologically active ingredients.

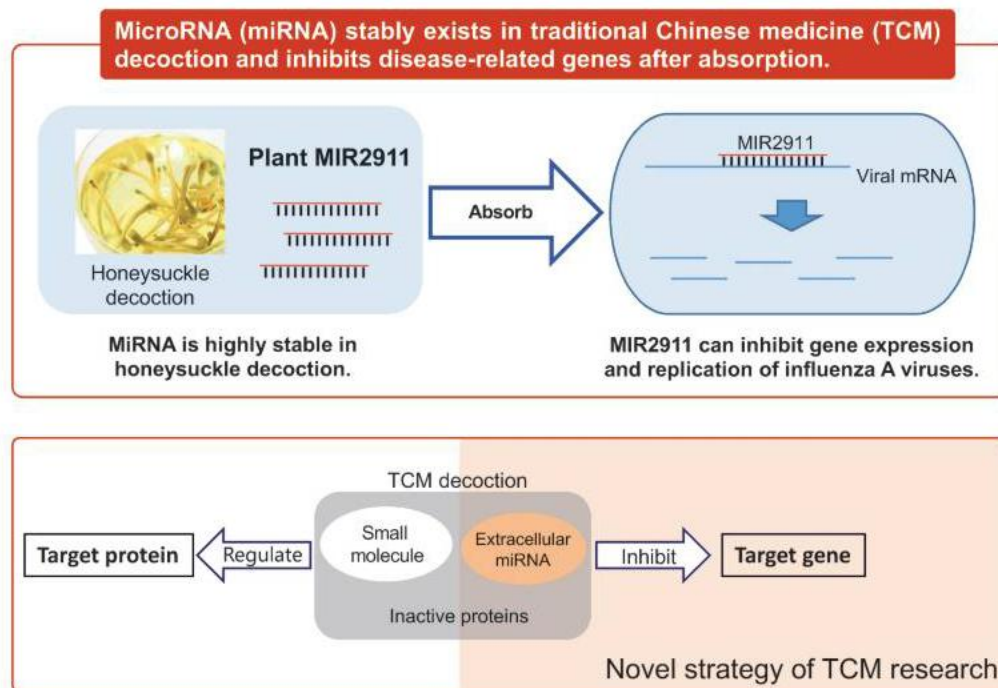

Figure 4. Some highly stable microRNAs (miRNAs) have been found in traditional Chinese medicine honeyuckle (*Lonicera japonica*) decoctions. Research suggests that an atypical miRNA called MIR2911, identified in honeyuckle decoction, binds to viral mRNA and exerts an inhibitory effect on the replication of influenza A viruses¹¹.

The suggestion that plant-derived small RNAs (miRNA is classed as a small RNA) may affect human physiology has led to a new avenue of research in TCM. Some ultra-stable extracellular miRNAs retained in TCM herbs and decoctions for the prevention and treatment of diseases in TCM clinical practice are being studied. One example is honeyuckle (*Lonicera japonica*), a well-known Chinese plant used in TCM to treat infections with influenza virus. Zhang's group found that MIR2911, a honeyuckle-encoded atypical miRNA, was selectively retained in the boiled honeyuckle decoction and had excellent stability and an intact sequence¹¹. The group suggests that the high guanine and cytosine (GC) nucleotide content and unique sequence of MIR2911 may lead to its stability during the boiling process because two mutant versions of MIR2911 with reduced GC content were not stable. *In vitro* study¹¹ suggests that MIR2911 could target and counteract multiple viral genes of influenza

A viruses (IAVs). *In vivo* evidence demonstrates that gavage feeding the honeyuckle decoction leads to a significant elevation of MIR2911 in mouse blood and lung. Also, MIR2911 inhibited the replication in mouse models of various IAVs, including H1N1, H5N1 and H7N9, and alleviated viral infection-induced weight loss and reduced mortality. The study provided the first evidence that plant miRNA could be an active component in TCM and identified the first plant miRNA that could help to suppress viral infection (Fig. 4).

The mechanisms through which miRNAs resist degradation when boiled with water to prepare TCM decoctions are not yet understood. Studies by the Chengyu Jiang research group in Peking Union Medical College, Beijing, may provide an answer. The group suggests that the heating process facilitates co-assembly of small RNAs and lipids in the decoctions to reach a steady state. The resulting heat-stable exosome-like nanoparticles, called 'decoctosomes', could

enter human cells to deliver small RNAs that may exhibit therapeutic effects *in vivo*¹². The results suggest a route through which lipids form liposomes with small RNAs in boiling decoctions to facilitate the uptake of small RNAs into human cells.

The SARS-CoV-2 pandemic has highlighted the threat that viruses can pose to public health. Viruses can rapidly mutate, which means that developing effective vaccines can be a challenge. Developing broad-spectrum antiviral drugs can help to prepare for future disease outbreaks. An MIR2911 and MIR2911-enriched honeyuckle decoction may be a therapeutic strategy to subdue viral infection. Besides targeting various subtypes of IAVs, studies suggest that honeyuckle-derived MIR2911 could directly inhibit the replication of varicella-zoster virus (the pathogen that causes chicken pox on primary infection and herpes zoster or shingles on reactivation) and enterovirus 71 (a primary pathogen of hand, foot and mouth disease in children)

by targeting viral genes^{3,14}. The studies indicate broad-spectrum antiviral activity by MIR2911. Therefore, a MIR2911 and MIR2911-containing honeysuckle decoction could be a potential therapeutic treatment for people infected with various forms of viral infections.

FROM SCIENCE TO BIOTECHNOLOGY, A BOOMING INDUSTRY

The ultimate goal of fundamental research is to translate new discoveries into real-world applications. From this perspective, the presence of miRNAs in the extracellular environment has served as a stimulus to three important avenues of research: (i) the potential that extracellular miRNAs may serve as disease biomarkers; (ii) the potential of EV-encapsulated miRNAs to serve as a novel mode of RNAi-based gene therapy; and (iii) the potential to engineer edible plants to biosynthesize and deliver miRNA medication for use in oral gene therapy.

The ability to diagnose a disease at an early stage is clearly beneficial. Diagnostic techniques such as biopsy, endoscopy and laparoscopy are usually invasive, but a blood sample could be a more efficient tool to help researchers identify biomarkers in serum or plasma. An ideal blood biomarker would fulfil many criteria, including: a high degree of specificity and sensitivity; enabling clinicians to detect a disease in its early stages and monitor a patient's physiological and pathological status; remaining stable within a sample; and allowing rapid and accurate detection. Circulating miRNAs meet most of the criteria. For complicated diseases such as cancer, the variability between patients means that using just one protein marker is an unreliable method to determine disease status. In contrast, fingerprints consisting of a set of circulating miRNAs

would have higher sensitivity and specificity compared to protein markers. Chen-Yu Zhang's group has revealed that circulating miRNAs are useful in screening and detection in the early stages of some diseases¹⁵, which may be because cells can spontaneously secrete increased amounts of miRNAs into the blood in response to the early onset of diseases. Circulating miRNAs are stably present in blood and can have high abundance and integrity, even after a long period of sample storage. The concentration of circulating miRNAs is relatively low (that is, in the femtomolar range), but by using tools such as quantitative reverse transcription-polymerase chain reaction, microarrays and RNA sequencing they can be detected in a small sized sample. One of the bottlenecks in the field is the lack of standardised methodology to assess circulating miRNAs. Future approaches to help identify miRNAs as potential diagnostic tools could be to develop methods to stratify miRNA-containing EVs and miRNA-bound protein complexes, and to research sensitive techniques to identify EVs based on tissue origin and surface proteins.

RNAI THERAPEUTICS

Chen-Yu Zhang's group from SLIS of NJU has explored the therapeutic potential of EVs as delivery vehicles for small RNAs. The group is interested in RNAi therapeutics but the lack of a safe and efficient delivery system has hindered its clinical application. Zhang's group reasoned that they could recruit the body's own RNA transport system: EVs. EVs are natural vesicles secreted by endogenous cells to protect and transport small RNAs across cells and biological barriers and therefore should be biocompatible with the host's immune system. In several studies, Zhang's group achieved potent target gene silencing and symptom relief in animal models^{16,17}. Clinical

applications of EV-mediated small RNA delivery will depend upon solving problems such as standardising the complicated purification protocols of EVs, developing feasible methods to harvest sufficient quantities of EVs for clinical use, improving robust methods to load siRNA cargo into EVs and designing techniques to manipulate EV content and delivery. Research groups at SLIS of NJU envision that EV-mediated small RNA therapeutics will develop rapidly and become a breakthrough in gene therapy.

Despite significant advances in injectable, transdermal and nasal routes for drug administration, the oral route is preferred because of its convenience for the patient. Unfortunately, oral administration of RNAi therapeutics has been hampered by physiological barriers in the gastrointestinal tract. Advances in cross-kingdom miRNA transfer may help to overcome the major challenges. Plants seem to be ideal carriers for therapeutic miRNAs because some plant miRNAs are resistant to the digestive process. Zhi Hong's group from SLIS of NJU has developed a strategy to deliver small RNAs as therapeutic medication by engineering transgenic plants to express therapeutic miRNAs. The group engineered a lettuce to biosynthesize artificial miRNAs to specifically target the hepatitis B virus surface antigen gene (*HBsAg*) with the endogenous miRNA biogenesis machinery of the lettuce¹⁸. After oral administration of the lettuce decoction, artificial miRNAs were absorbed and delivered into the liver to inhibit *HBsAg* expression in transgenic mice. After 15 months of treatment, the expression of *HBsAg* was reduced and liver injury was significantly alleviated in the mice and no toxicological effects were observed¹⁸. This strategy utilizes the plant endogenous miRNA biogenesis machinery to produce methylated miRNAs for increased stability

while significantly reducing the cost of production. Plant miRNA-based oral therapy may provide an effective, nontoxic and affordable treatment option for disease.

To facilitate and accelerate the commercialization of these scientific breakthroughs, Nanjing University has established NJU Advanced Institute of Life Sciences; Jiangsu Engineering Research Center for MicroRNA Biology and Biotechnology; and Nanjing Drum Tower Hospital Center of Molecular Diagnostic and Therapy. Very recently, Nanjing University has established the Institute of Artificial Intelligence Biomedicine, a big data-empowered tech transfer platform that aims to connect all the dots from science to technology to products. The future goal is that the original scientific theories created by Dr Chen-Yu Zhang's 'Nanjing school of thought' will become medical innovations that could benefit the health of all people.

REFERENCES

- Chen, X. *et al. Cell Res.* **18**, 997-1006 (2008).
- Mitchell, P. S. *et al. PNAS USA* **105**, 10513-10518 (2008).
- Zen, K. & Zhang, C. *Y. Med. Res. Rev.* **32**, 326-348 (2012).
- Zhang, Y. *et al. Mol. Cell* **39**, 133-144 (2010).
- Chen, X., Liang, H., Zhang, J., Zen, K. & Zhang, C. *Y. Trends Cell Biol.* **22**, 125-132 (2012).
- Yin, Y. *et al. Cell Res.* **24**, 1164-1180 (2014).
- Zhang, L. *et al. Cell Res.* **22**, 107-126 (2012).
- Ledda, B., Ottaggio, L., Izzotti, A., Sukkar, S. G. & Miele, M. *Cell Biosci.* **10**, 1 (2020).
- Zhu, K. *et al. PLoS Genet.* **13**, e1006946 (2017).
- Zeng, J. *et al. Cells.* **8**, 371 (2019).
- Zhou, Z. *et al. Cell Res.* **25**, 39-49 (2015).
- Li, X. *et al. Sci. China Life Sci.* **62**, 333-348 (2019).
- Huang, Y. *et al. J. Neurovirol.* **25**, 457-463 (2019).
- Li, X. *et al. Antiviral Res.* **152**, 117-123 (2018).
- Chen, X. *et al. Int. J. Cancer.* **130**, 1620-1628 (2012).
- Zhang, Y. *et al. Biomaterials* **35**, 4390-4400 (2014).
- Liu, Y. *et al. Sci. Rep.* **5**, 17543 (2015).
- Zhang, S. *et al. Biomaterials* **210**, 83-93 (2019).

It's just what the doctor ordered.

Scientific American Health & Medicine

Explore the cutting-edge science of everything from human health and epidemiology to biotechnology and medicine

6 issues per year

Select articles from *Scientific American* and *Nature*

Read anytime, anywhere

sciam.com/health-medicine



Hurricane Infamy

Storm names are retired based on death or damage

Since 1950, when a formal naming process began, the monikers of 89 northeastern Atlantic, Caribbean and Gulf of Mexico hurricanes have been retired because of the deaths or excessive financial damage they caused. A list of 21 names is designated for each of six successive years; in year seven, the set from year one repeats, and so on. (Beyond 21, which is rare, names come from the Greek alphabet.) Retired names are replaced. A storm “Florence” formed eight times before it achieved infamy in 2018. In the mid-1900s fatalities may have been high even when damages were modest, in part because early-warning systems and emergency responses were not as effective as today.

In recent times damages have mounted largely because coastal population and value of infrastructure have risen dramatically.

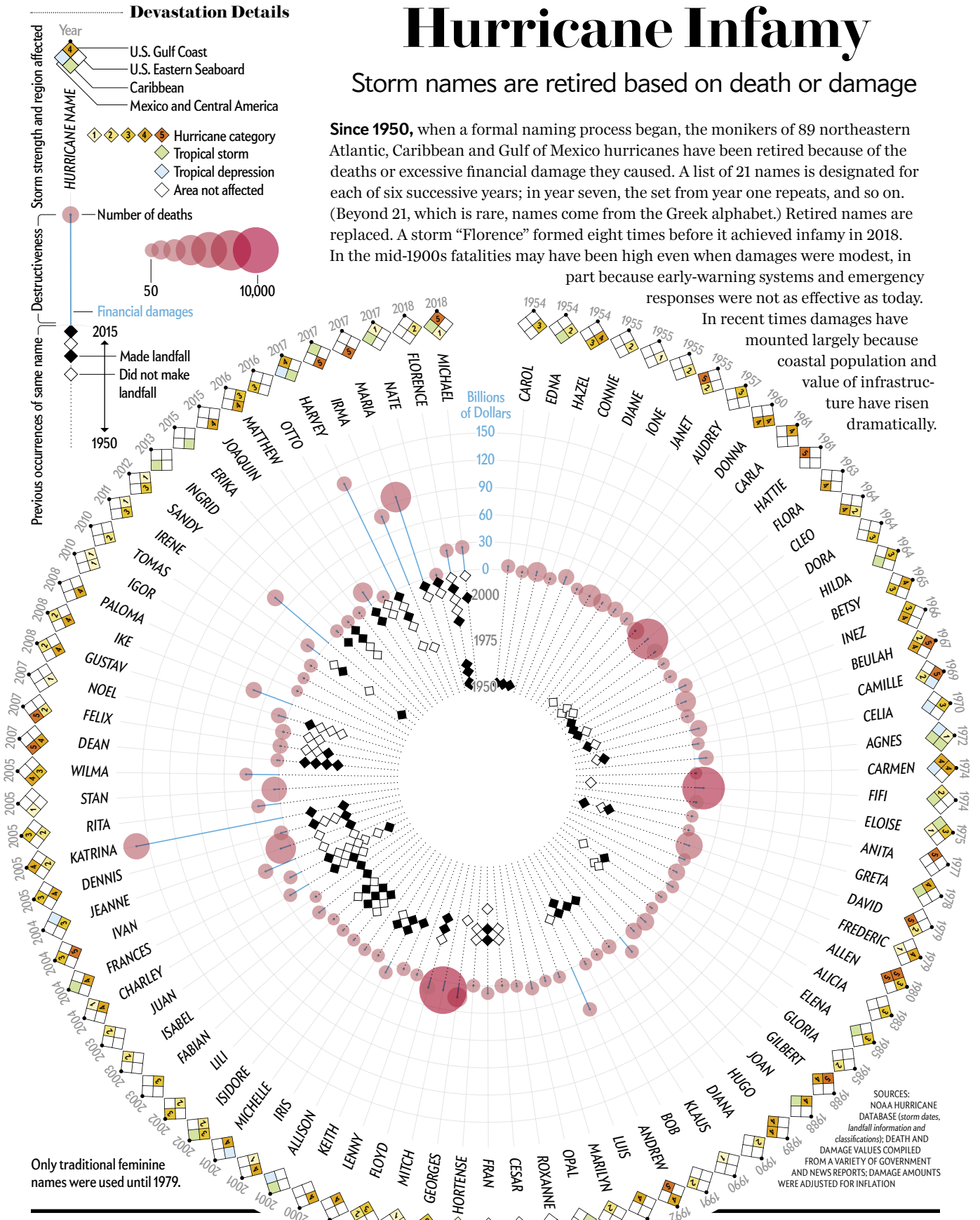



United in dedication, we share our gratitude

In celebration of International Nurses Day from 12 to 18 May 2020, Qatar Airways gave away 100,000 complimentary tickets to frontline healthcare professionals in recognition of their hard work. At Qatar Airways, we are grateful for the commitment of healthcare professionals around the world who continue to selflessly work to keep us safe.

It was our turn to give back to those on the healthcare frontlines, even though there are no gestures that are enough to repay their bravery. With our offer of complimentary tickets, we hope they can plan for a well-deserved holiday when the time is right.

qatarairways.com



GOING PLACES TOGETHER